

AURORA

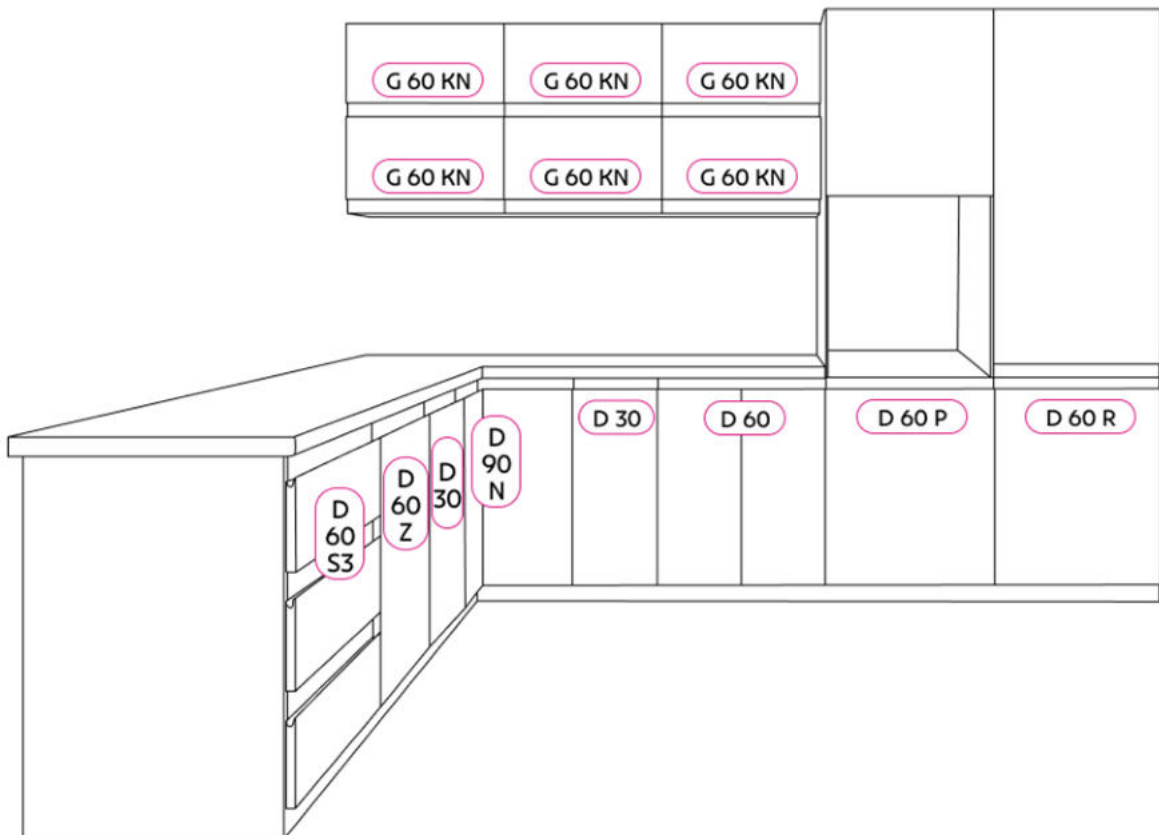
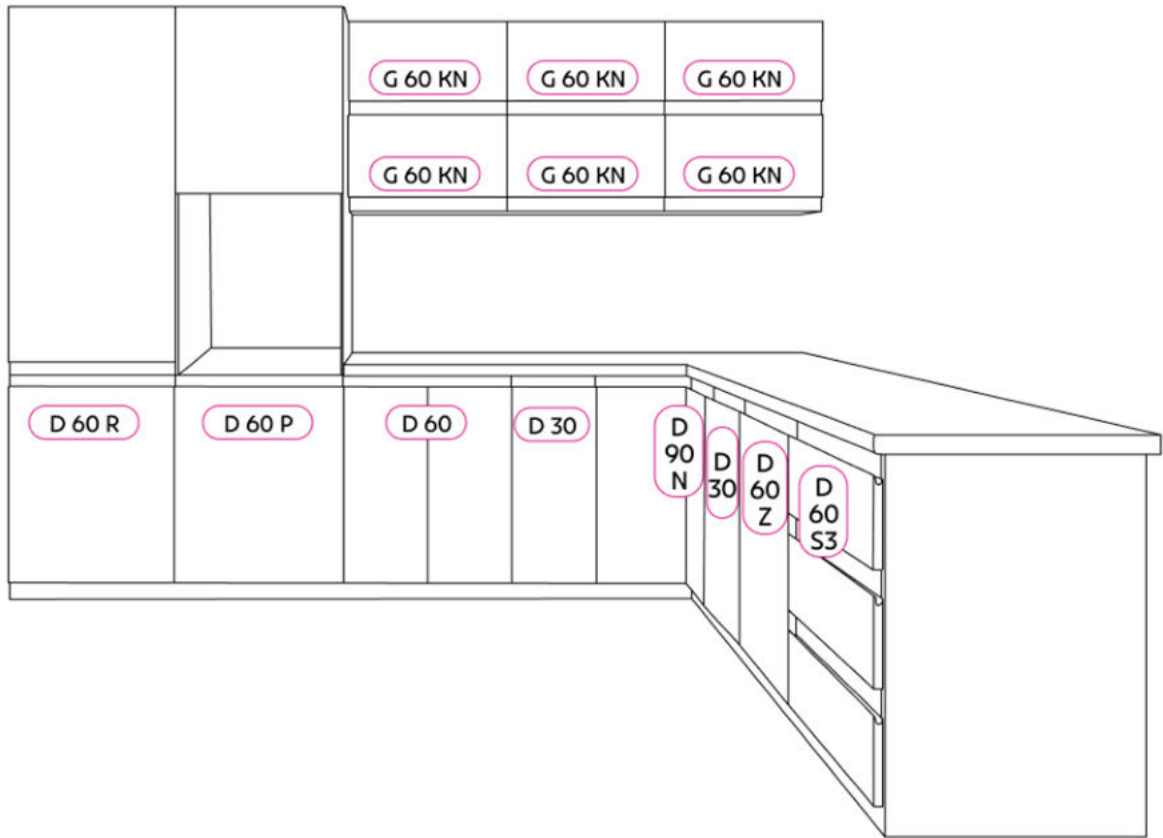

Draga stranka!

Pred sestavljanjem pohištva natančno preberite naslednja navodila

ELEMENTI S SLEDOVI MONTAŽE, KI SO REKLAMIRANI ZARADI MEHANSKIH POŠKODB ALI NAPAK, NISO PREDMET REKLAMACIJE
V primeru kakršnih koli dvomov med sestavljanjem se obrnite na nas na naslednjo telefonsko številko:
(+48) 0-71 315 77 52 od ponedeljka do petka od 8.00 do 16.00.

Pohištvo je sestavljeno v skladu z naslednjimi koraki, opisanimi v priročniku. Oznake, nalepljene na delih pohištva, ustrezajo oznakam v priročniku. **Pozor! Čepe nabijte v ozki ravnini elementa. Zadnjo stran pohištva in dno predala sestavite po nastavitvi diagonale (glejte sliko).**

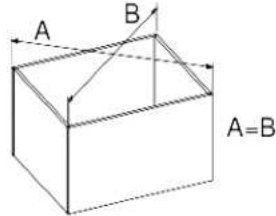

Zadnji korak je postavitve pohištva v pravilen položaj in preverjanje navpičnega in vodoravnega položaja pohištva ter nastavitve površin na tečajih s pomočjo ravnila.

Nasveti za nego.

Pohištvo čistite samo s krpo za prah (suho ali vlažno)! Ne uporabljajte nobenih kemičnih čistil! Očistite steklene elemente s čistili za steklo, ki so na voljo na trgu, in kot je navedeno na embalaži izdelka.

Pozor! Barva okrasne letve in oboda pohištva se lahko nekoliko razlikuje od barve pulta. To je odvisno od serije izdelka.

To NI podlaga za reklamacijo.

Pozor! Proizvajalec pohištva si pridržuje pravico do oblikovnih sprememb ponujenega pohištva, ne da bi pri tem spremenil splošni značaj pohištva. Dimenzije pohištva se lahko spremenijo. Rozmery nábytku sa môžu meniť.

Spoštovani kupec!

Zahvaljujemo se vam za nakup izdelka. Čestitamo vam za vašo odločitev. Verjamemo, da vam bo naše pohištvo dolgo služilo in vam prinašalo zadovoljstvo. Pozorno preberite pogoje uporabe in se seznanite z vzdrževanjem našega pohištva, da boste v njem lahko uživali čim dlje.

Potrudili smo se, da je kupljeno pohištvo visokokakovostno, sodobno in funkcionalno. Vendar pa se v primeru kakršnih koli neskladij obrnite neposredno na prodajalca, da bo lahko čim prej odpravil morebitne napake.

GARANCIJSKI POGOJI

1. Garant mora kupcu zagotoviti dobro kakovost in pravilno delovanje pohištva za obdobje 24 mesecev od datuma prodaje pohištva.
2. Kupec mora ob nakupu izdelka v sestavljenem stanju preveriti kakovost in popolnost izdelka ter delovanje glavnih mehanizmov in bistvenih sestavnih delov.
3. Garancija ne krije škode, ki je nastala zaradi nepravilnega ali neprevidnega prevoza, prenašanja ali slabe montaže izdelka, pa tudi ne škode, ki je posledica naključnih dogodkov ali poškodb izdelka, zaradi katerih je bila cena izdelka znižana. Vidne napake, mehanske poškodbe in količinsko pomanjkanje sestavnih delov ali drugih dodatkov pohištva, ki se prodaja kot sestavljeno, mora kupec prijaviti ob nakupu. V nasprotnem primeru v obsegu zgoraj naštetih zadev niste upravičeni do garancije.
4. Zaradi kakršne koli spremembe ali predelave pohištva z vaše strani je pravica do uveljavljanja garancije nična.
5. Garant ne odgovarja za neizpolnitev predmeta pogodbe, če je kupec vedel ali bi razumno moral vedeti za takšno nezdržljivost.
6. Kupec mora prodajalca obvestiti o neskladnosti izdelka v zvezi z njegovo vgradnjo v lastnem interesu v roku dveh mesecev od prejema obvestila.
7. V primeru neskladnosti v garancijskem roku ali v primeru okvare tega izdelka je dolžan obvestiti kraj nakupa izdelka s predložitvijo garancijskega lista. Prodajalec se zavezuje in bo na reklamacijo odgovoril v 14 dneh od obvestila o neskladnosti izdelka s pogodbo. Če se ne bo odzval, to pomeni, da je reklamacijo priznal kot upravičeno.
8. Garancijski rok se podaljša za čas, ki preteče od prijave reklamacije do njene rešitve, če je v tem obdobju zaradi tega onemogočena uporaba izdelka.
9. V primeru, da izdelek ni skladen s pogodbo, garant jamči kupcu, da bo izdelek vzpostavil v pravilno stanje v skladu s pogodbo o zamenjavi delov.
10. V primeru, da je bila zamenjava pohištva brez napak ali je prišlo do odstopa od pogodbe, se poleg napak, zaradi katerih je prišlo do zamenjave ali odstopa od pogodbe, potrjuje tudi zmanjšanje kakovosti izdelka, ki presega raven običajne obrabe, ali je povezano tudi s spremembo ali predelavo izdelka, ki jo je opravil kupec ali jo je opravil kupec, pa tudi če je blago nepopolno (dobavljeno brez vseh sestavnih delov, brez delov ali neuporabnih dodatkov, opreme v obsegu, ki je potreben za namen pri morebitni nadaljnji prodaji), prodajalec kupcu zaračuna finančne stroške zamenjave ali nadomestitve poškodovanih enakovrednih izdelkov ter manjkajočih elementov.

PRAVILA ZA UPORABO POHIŠTVA

1. Pohištvo je treba uporabljati za predvideni namen in v skladu s pravili v skladu z merili predvidene uporabe.
2. Pohištvo je treba uporabljati v suhih, zaprtih in pred neugodnimi vremenskimi razmerami zaščitenih prostorih, pa tudi zaščiteni pred neposredno izpostavljenostjo sončni svetlobi. Temperatura zraka v prostoru naj bo med 10 in 30 °C, relativna vlažnost pa med 25 in 80 % . Pohištvo ne sme biti postavljeno manj kot pol metra pred aktivnimi radiatorji.
3. Priporoča se in zahteva izravnava pohištva, ki mora biti vedno postavljeno na stabilno površino.
4. Način sestavljanja pohištva, število sestavnih delov in dodatkov, ki so potrebni za sestavo in izvedbo namestitve, je določen na informacijski kartici, ki je v embalaži, opremljeni z okovjem za tip pohištva, ki se običajno proizvaja.

PRAVILA ZA UPORABO IN VZDRŽEVANJE POHIŠTVA

1. Pohištvo je izdelano iz laminata, zato je treba pri njegovem čiščenju upoštevati naslednja navodila:
 - umivajte z mehko in vlažno krpo.
2. Pri negi površine pohištva ne uporabljajte nobenih kemikalij ali abrazivnih krp.
3. Na površino pohištva ne odlagajte mokrih ali vročih predmetov.
4. Obnovo pohištvenih površin vedno zaupajte specializiranim servisnim podjetjem.

AURORA

D30

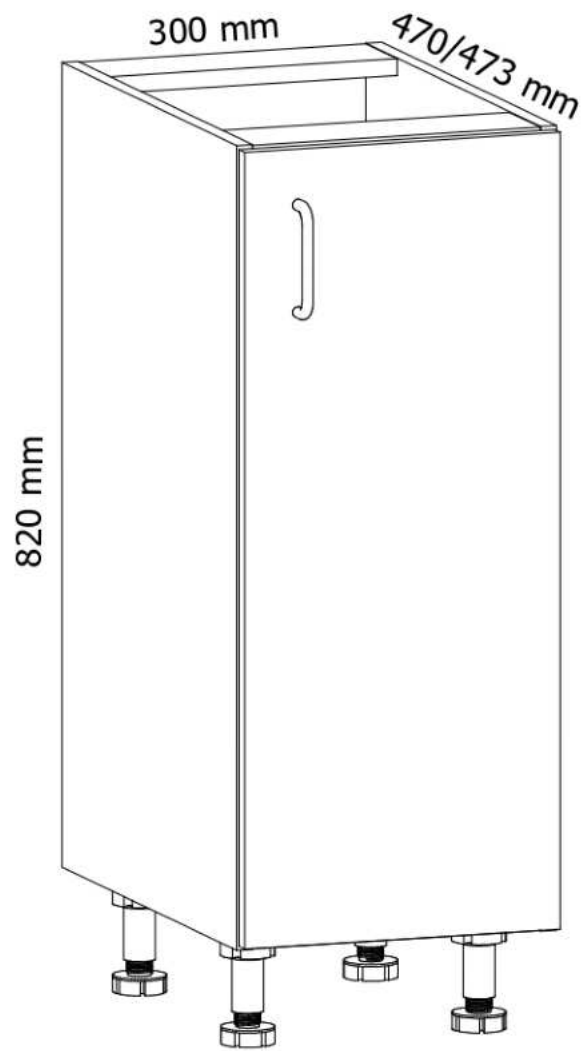

D30(P) / S30

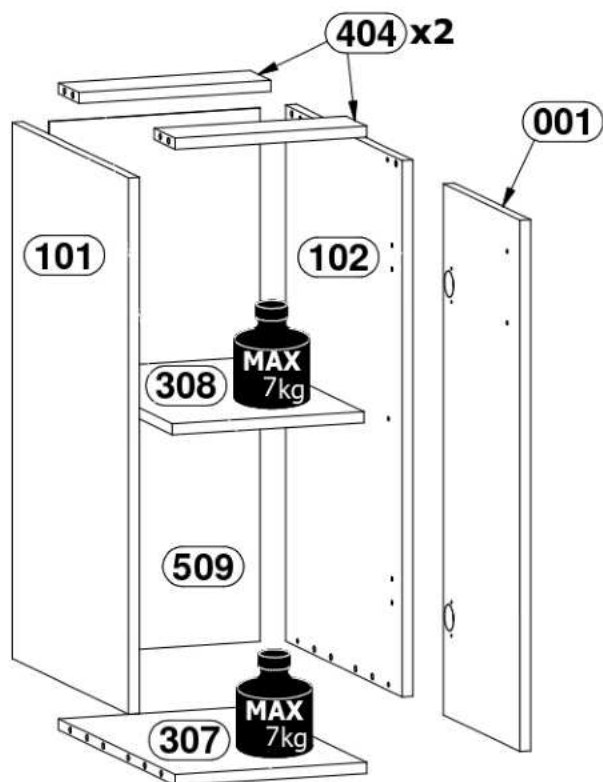
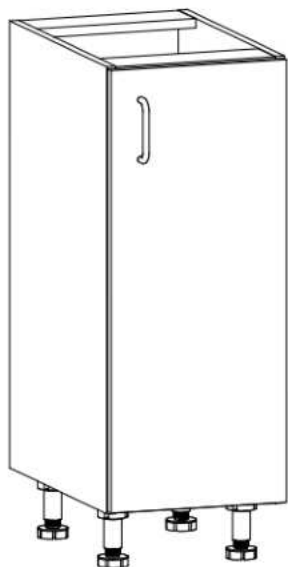

D30(L)

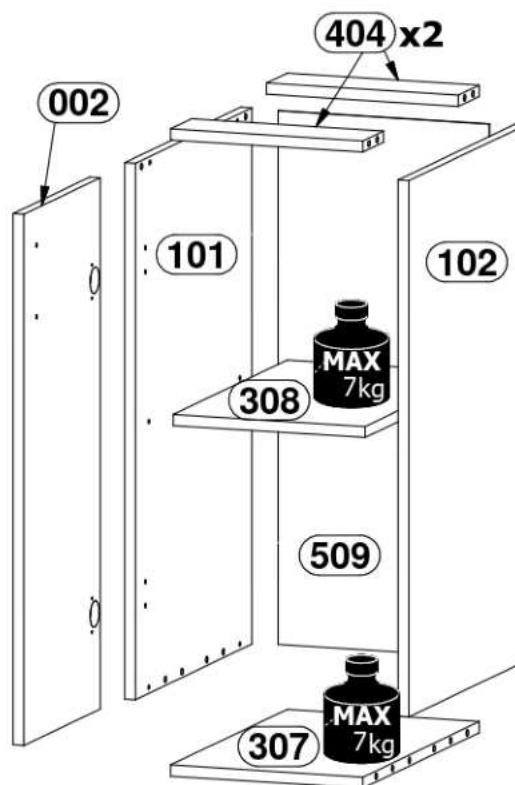
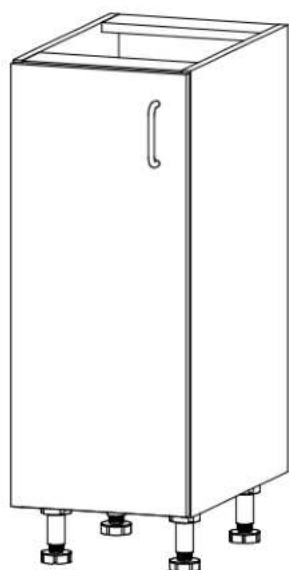

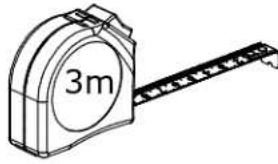
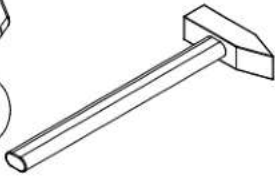
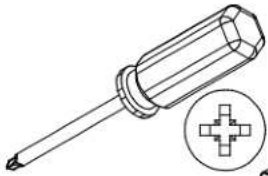

A1 x12

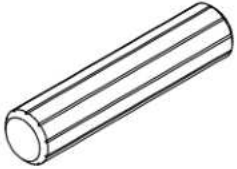

Ø8x35mm

B1 x8



Ø5x38mm

C1 x8

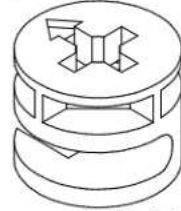

Ø15x12mm

E4 x4

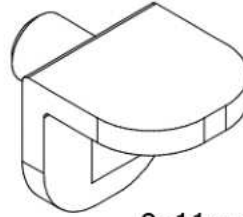

9x11mm

G1 x20

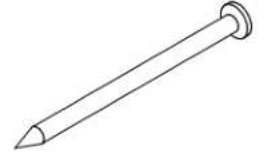

26mm

L1 x4



Ø50x95mm

U x1

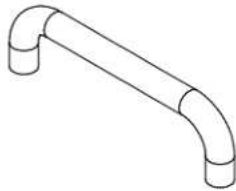

W2 x20

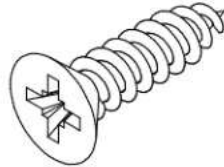

Ø3,5x16mm

X x2

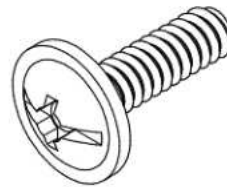

Zc1 x2

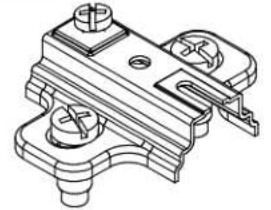

Zc2 x2

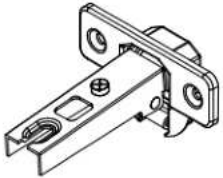

1

B1 x8



E4 x4

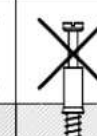
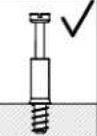
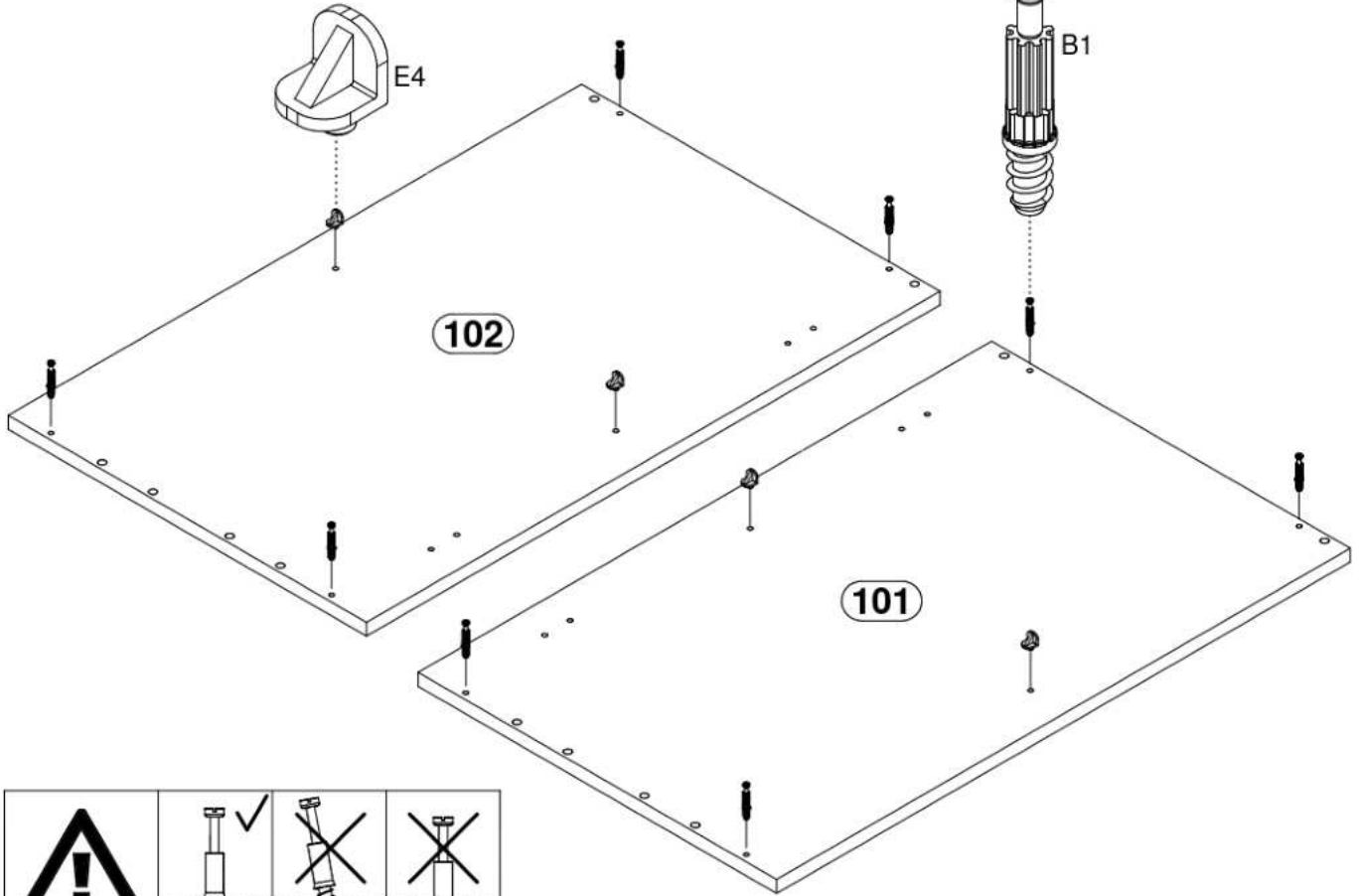
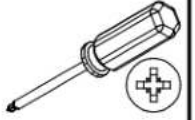
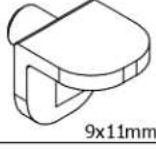

2

A1 x12



C1 x8

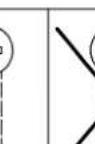
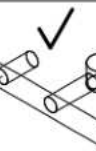
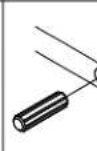
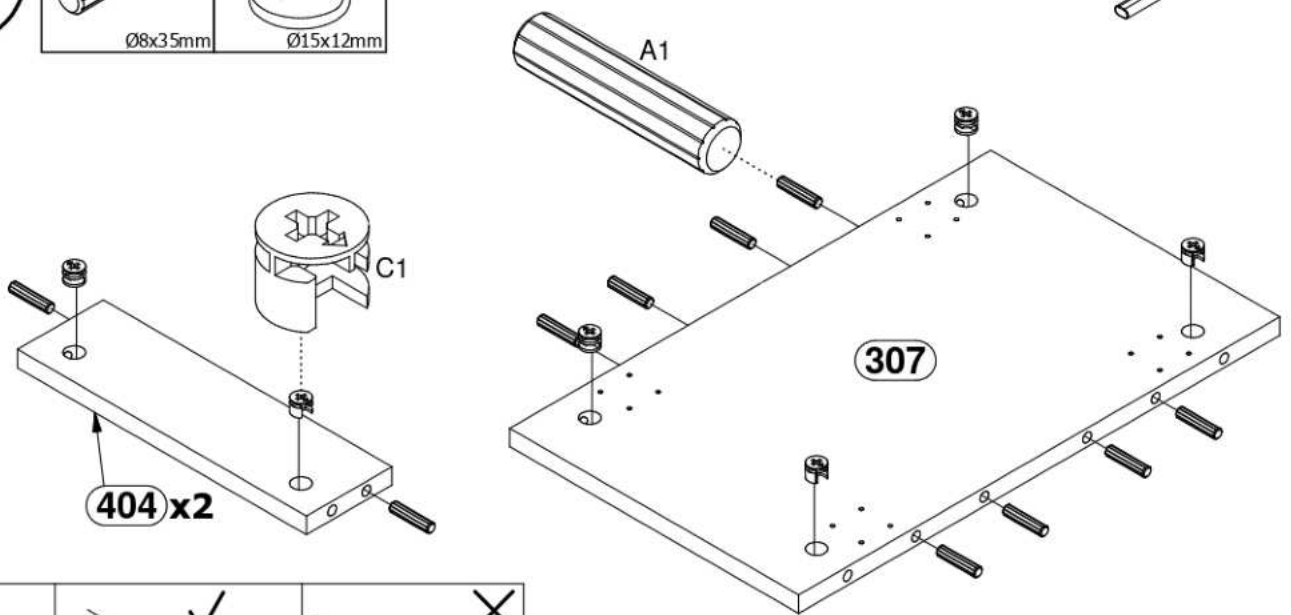

3

L1 x4



Ø50x95mm

W2 x16



Ø3,5x16mm

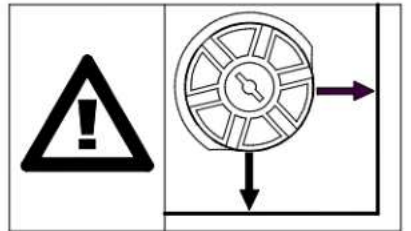
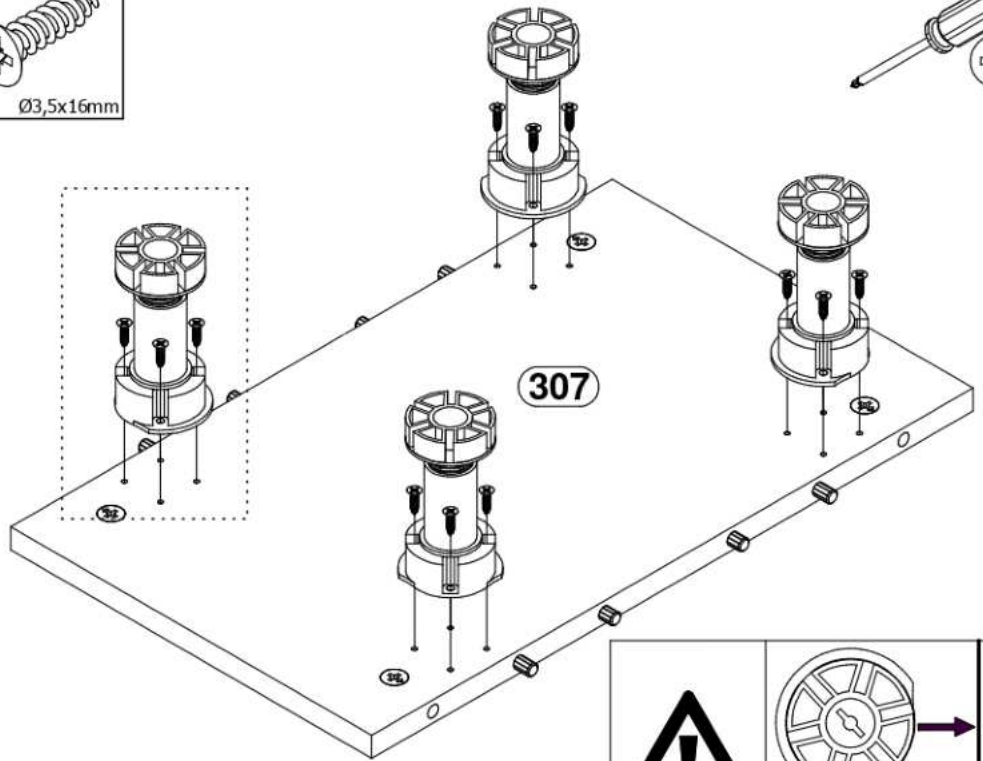
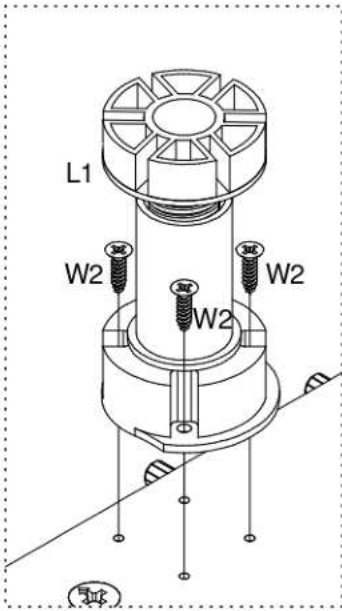
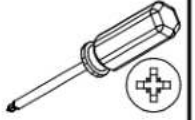

4

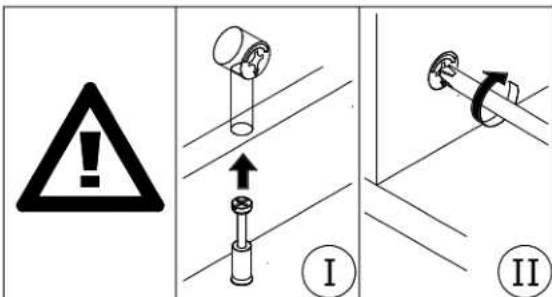
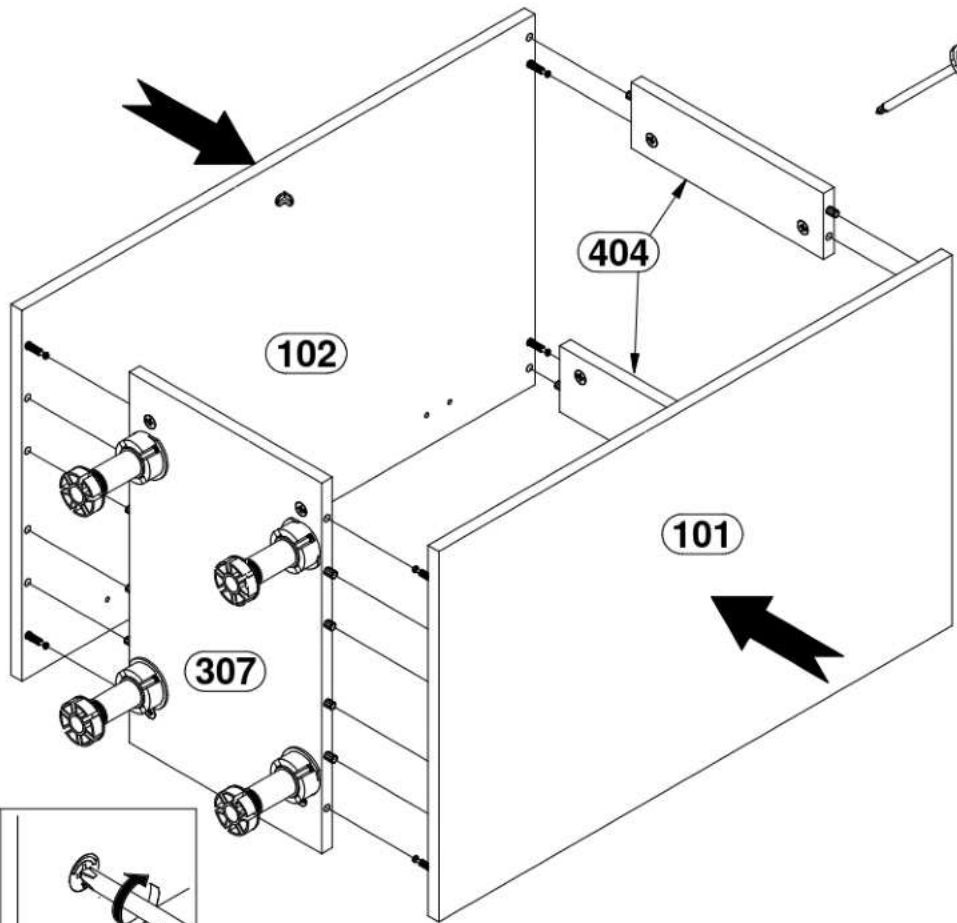

5

G1 x 20



26mm

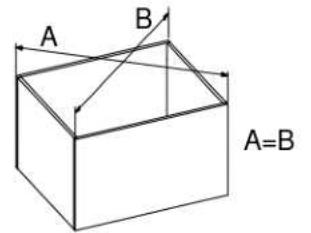
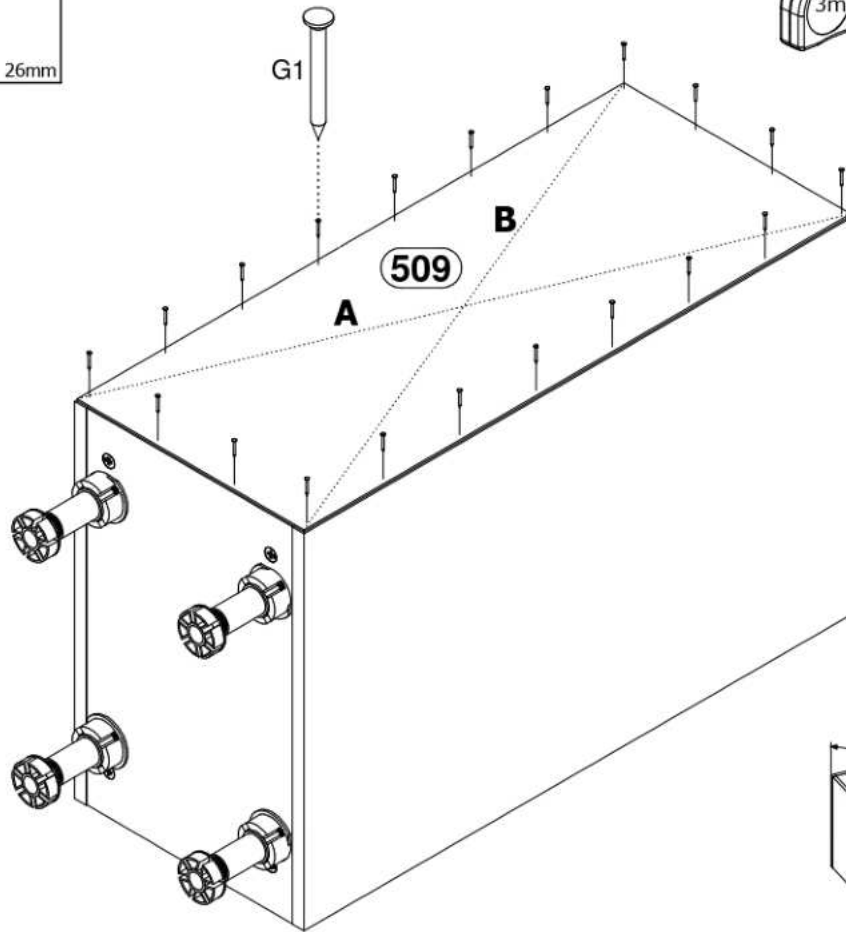
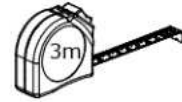

A=B ≡ 90°

6

W2 x 4



Ø3,5x16mm

Zc2 x 2

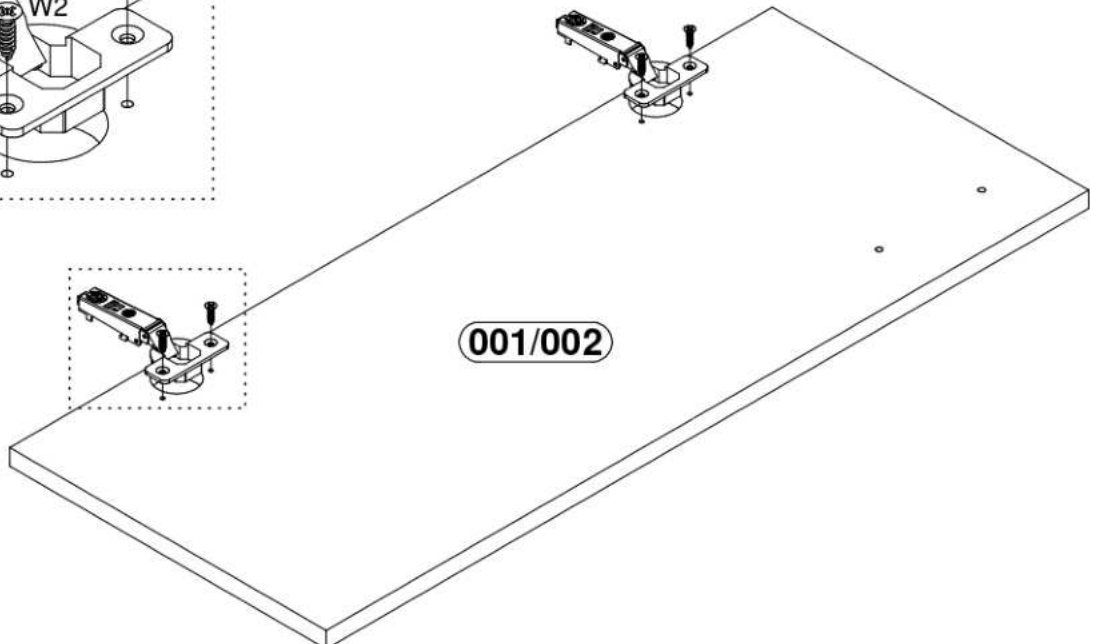
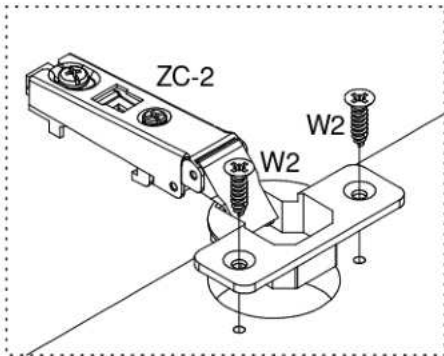
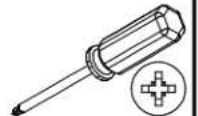

7

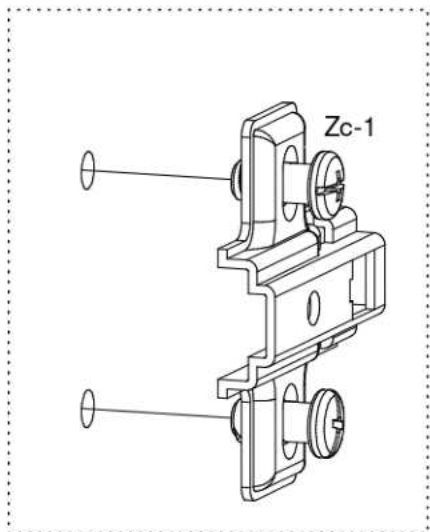
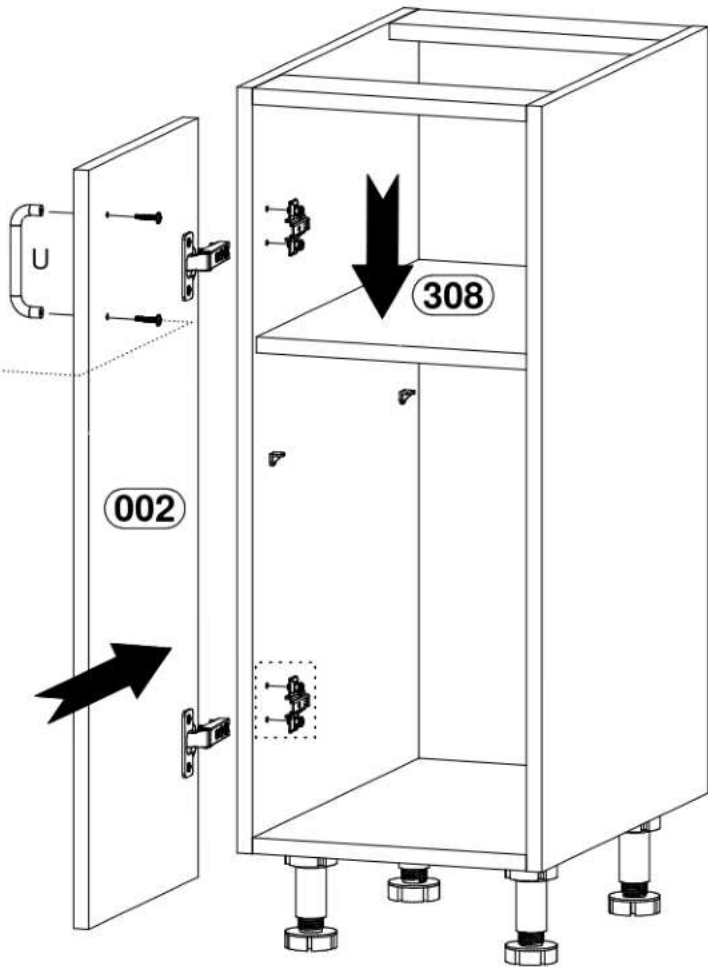
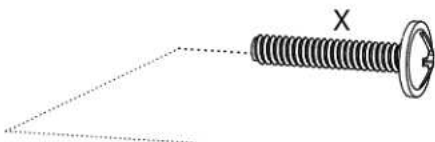
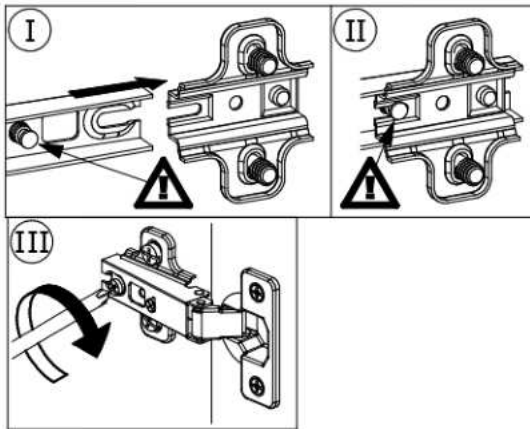
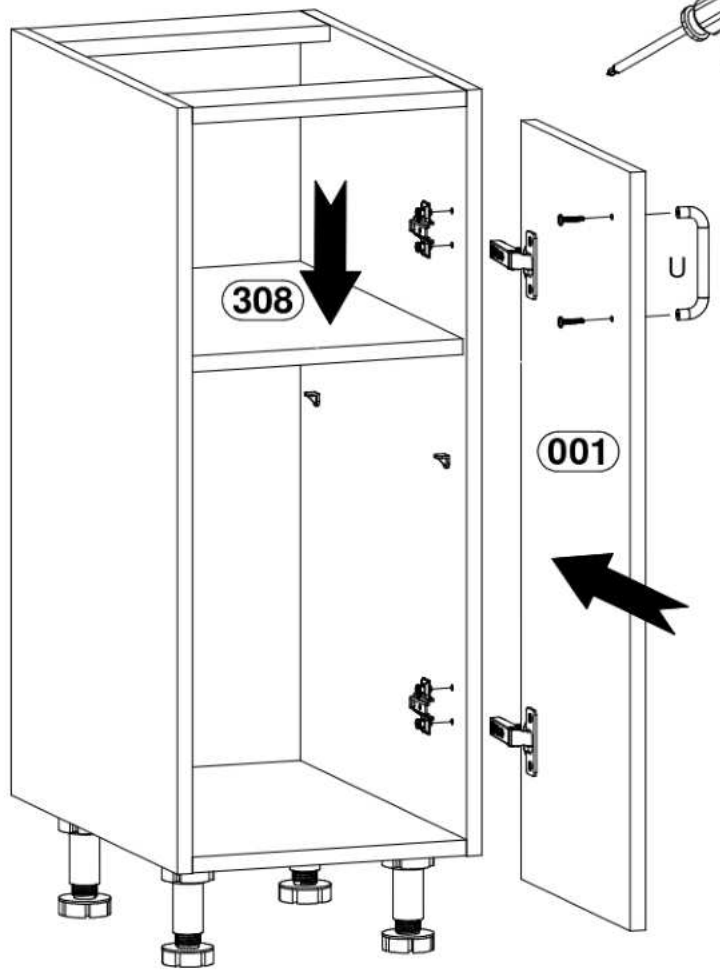
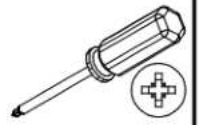
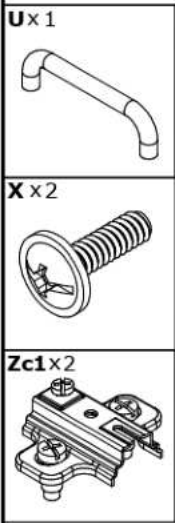

8

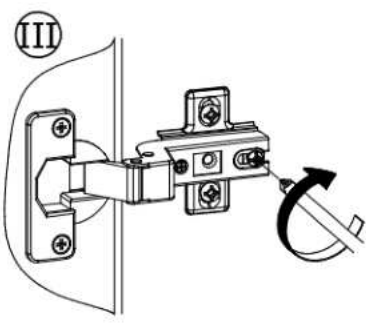
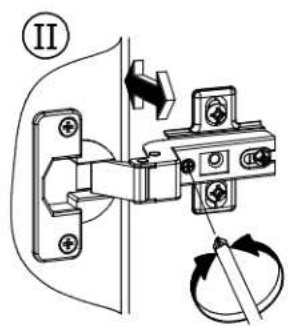
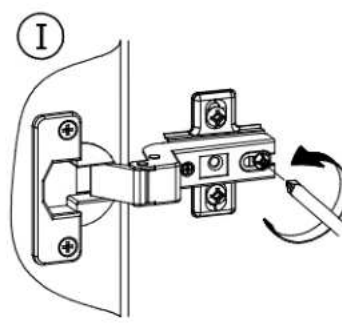
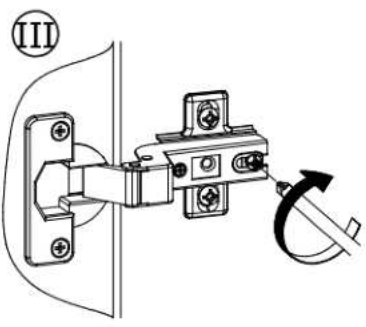
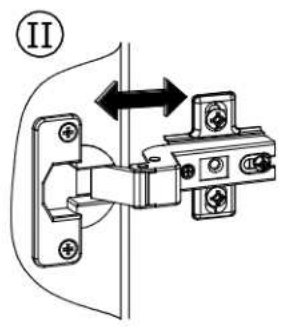
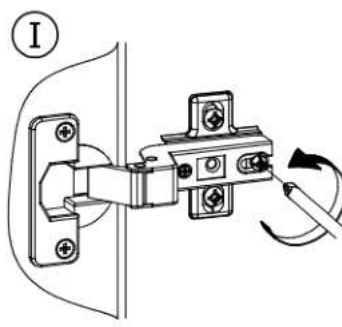
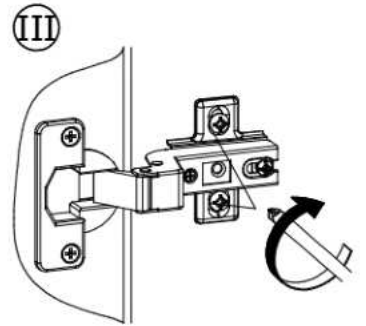
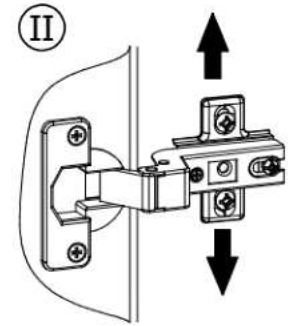
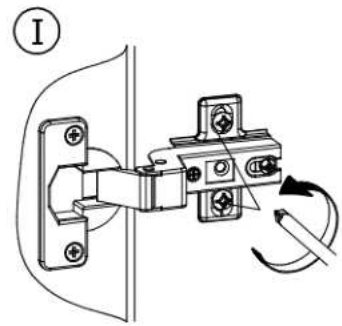
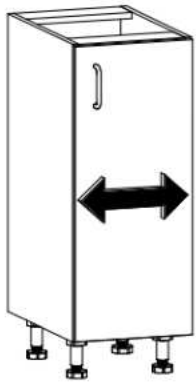
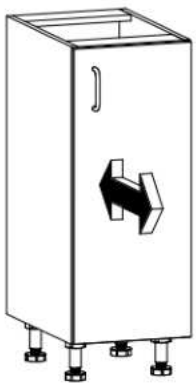
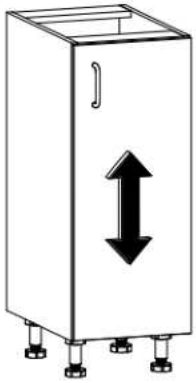
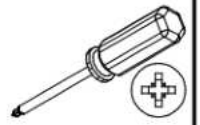

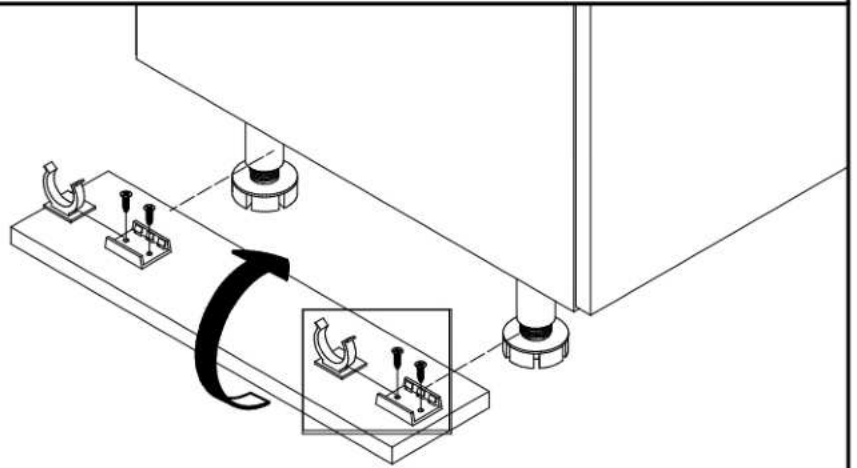
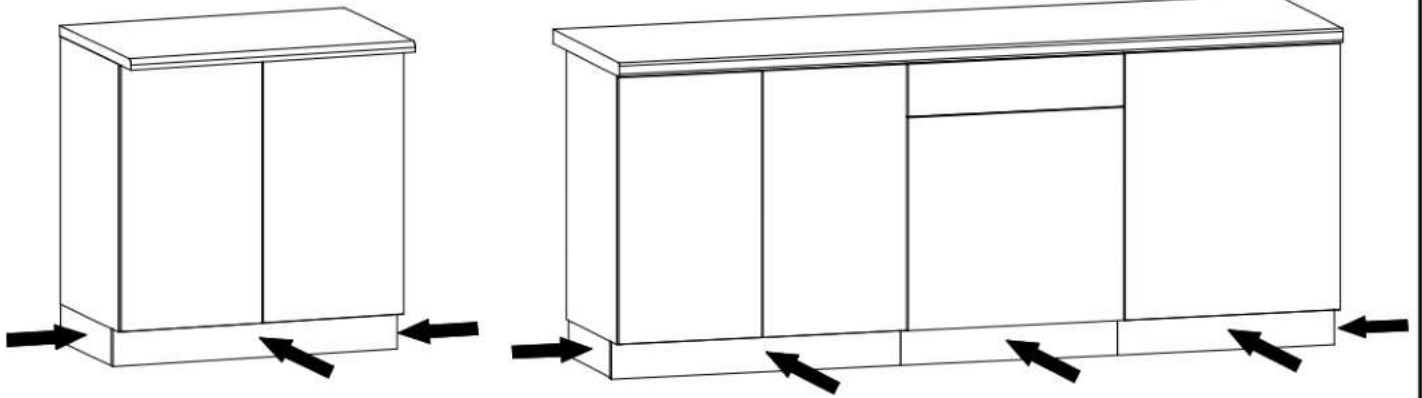
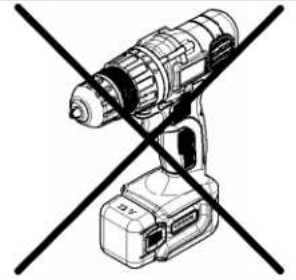
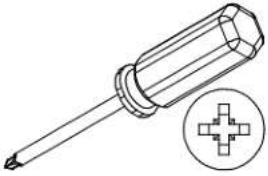

L6-a x4

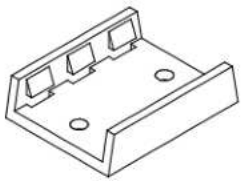

38x30x10mm

L6-b x4

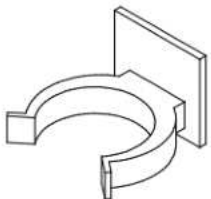

35x32x25mm

W2 x8

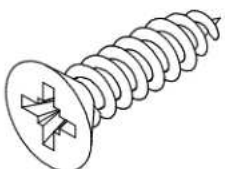

Ø3,5x16mm

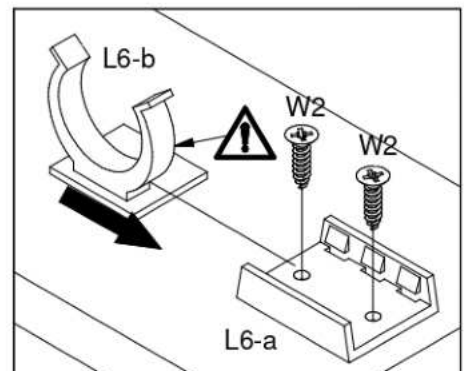

C2

L6-a x 2

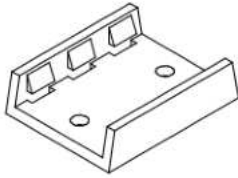

38x30x10mm

L6-b x 2

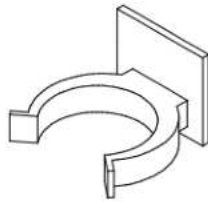

35x32x25mm

W2 x 4

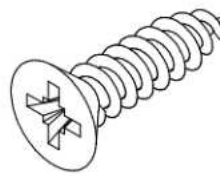

Ø3,5x16mm

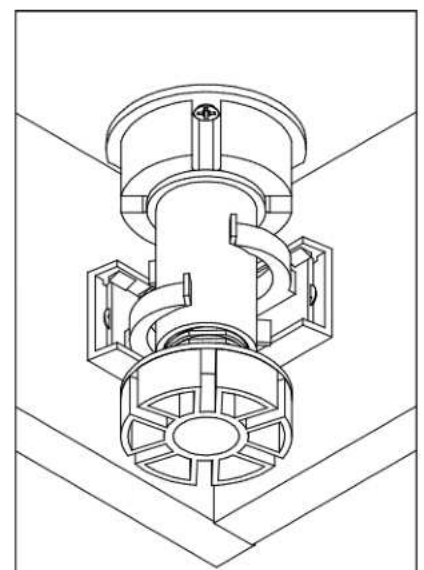
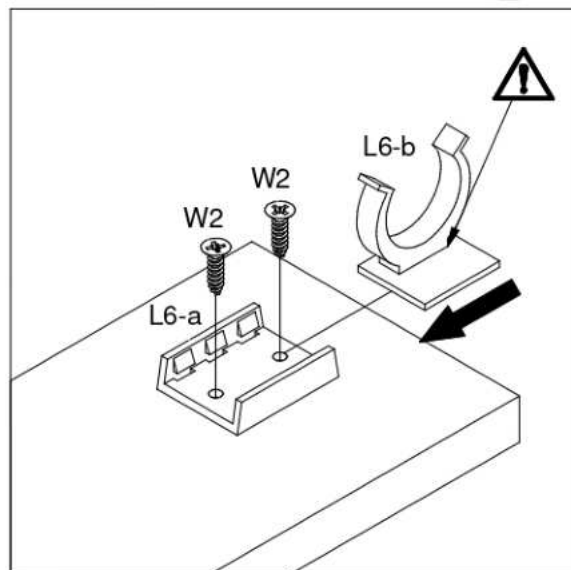
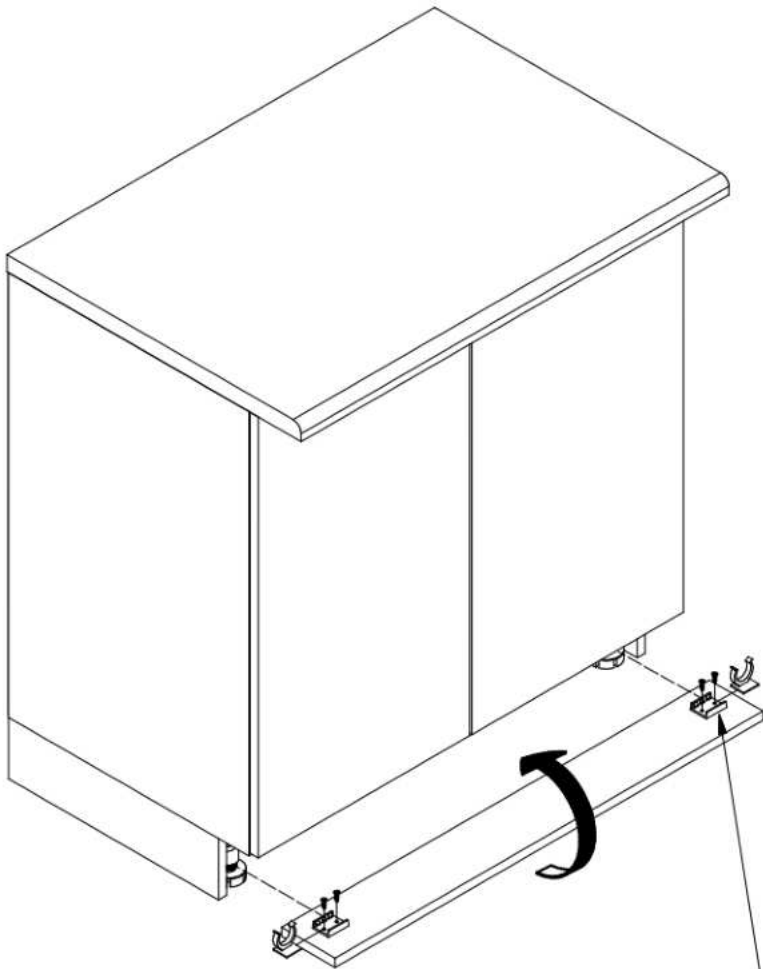
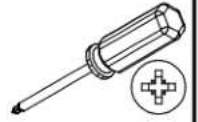

AURORA



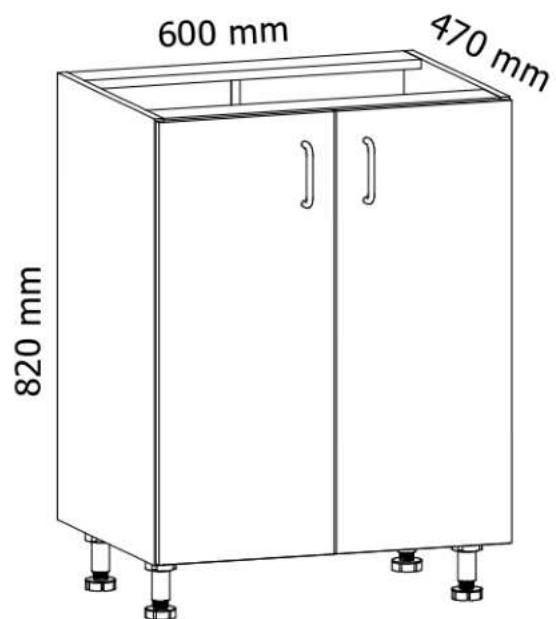



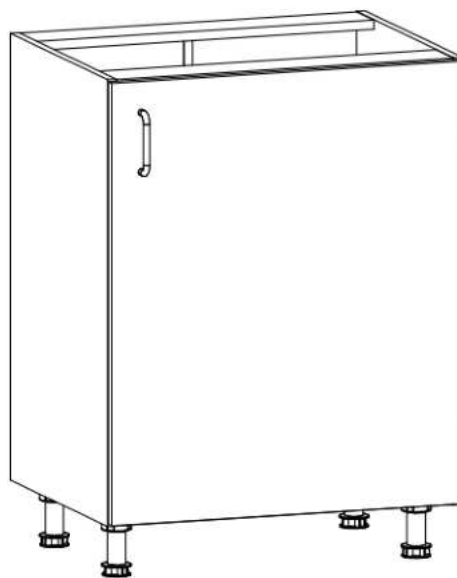
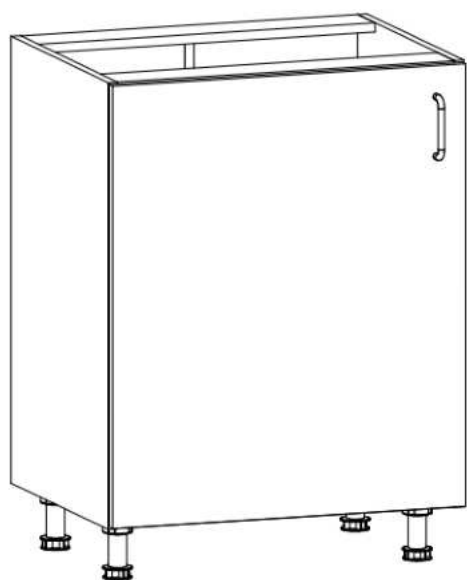

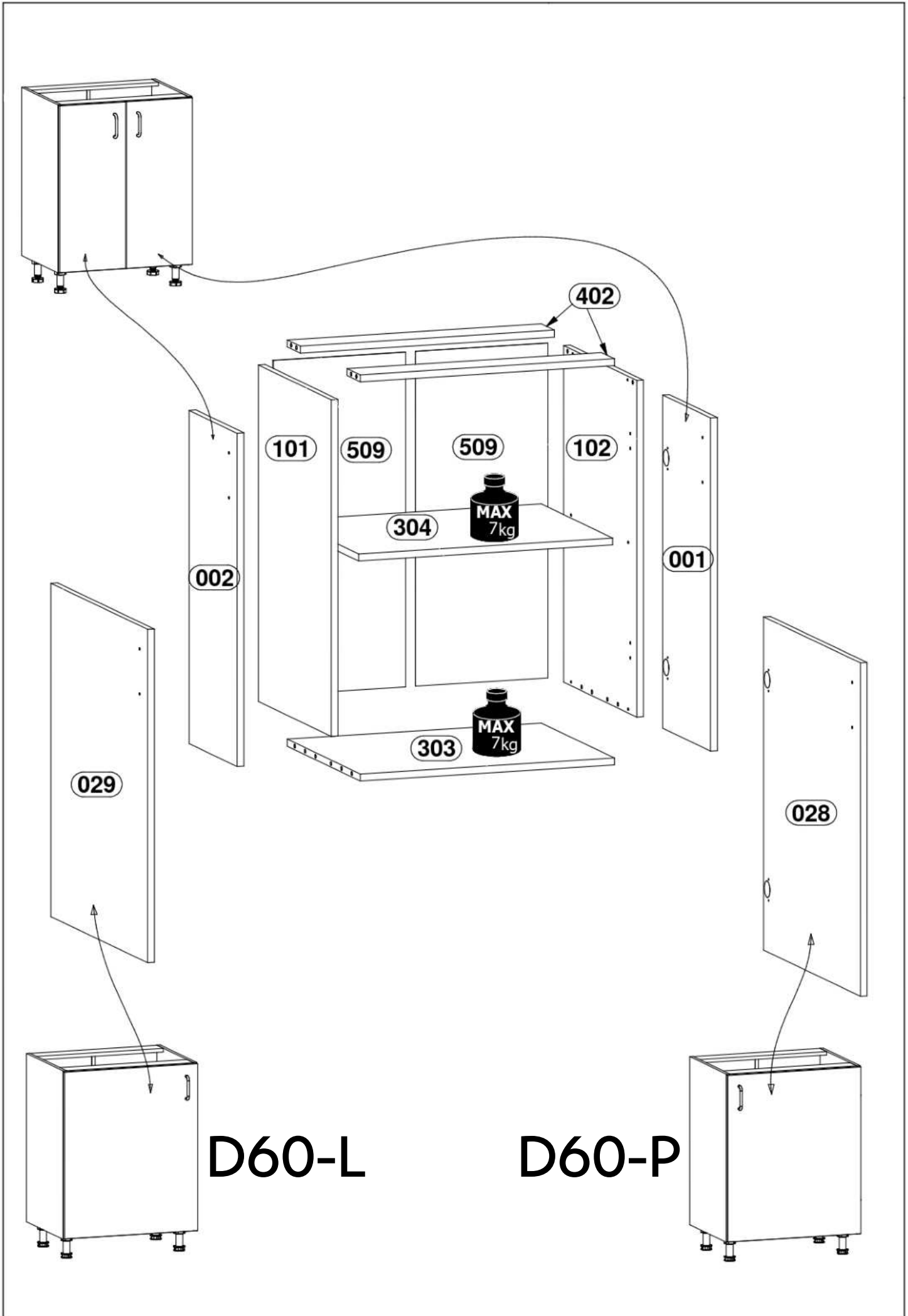
D60



D60-L / D60-P

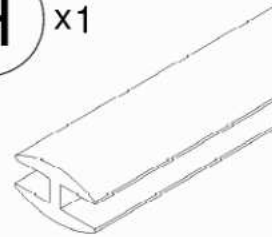
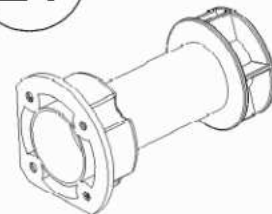

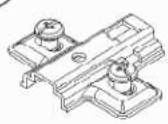
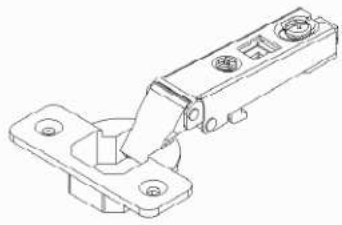

<p>A x12</p>  <p>Ø8x35mm</p>	<p>B x8</p> 	<p>C x8</p>  <p>Ø15x12mm</p>	<p>E x4</p> 
<p>G x27</p> 	<p>H x1</p>  <p>715 mm</p>	<p>L1 x4</p> 	<p>M x2</p> 
<p>W2 x24</p>  <p>Ø3,5x16mm</p>	<p>Y x8</p>  <p>Ø18 mm</p>	<p>Zc x4</p>  <p>Zc-1</p>	 <p>Zc-2</p>

1

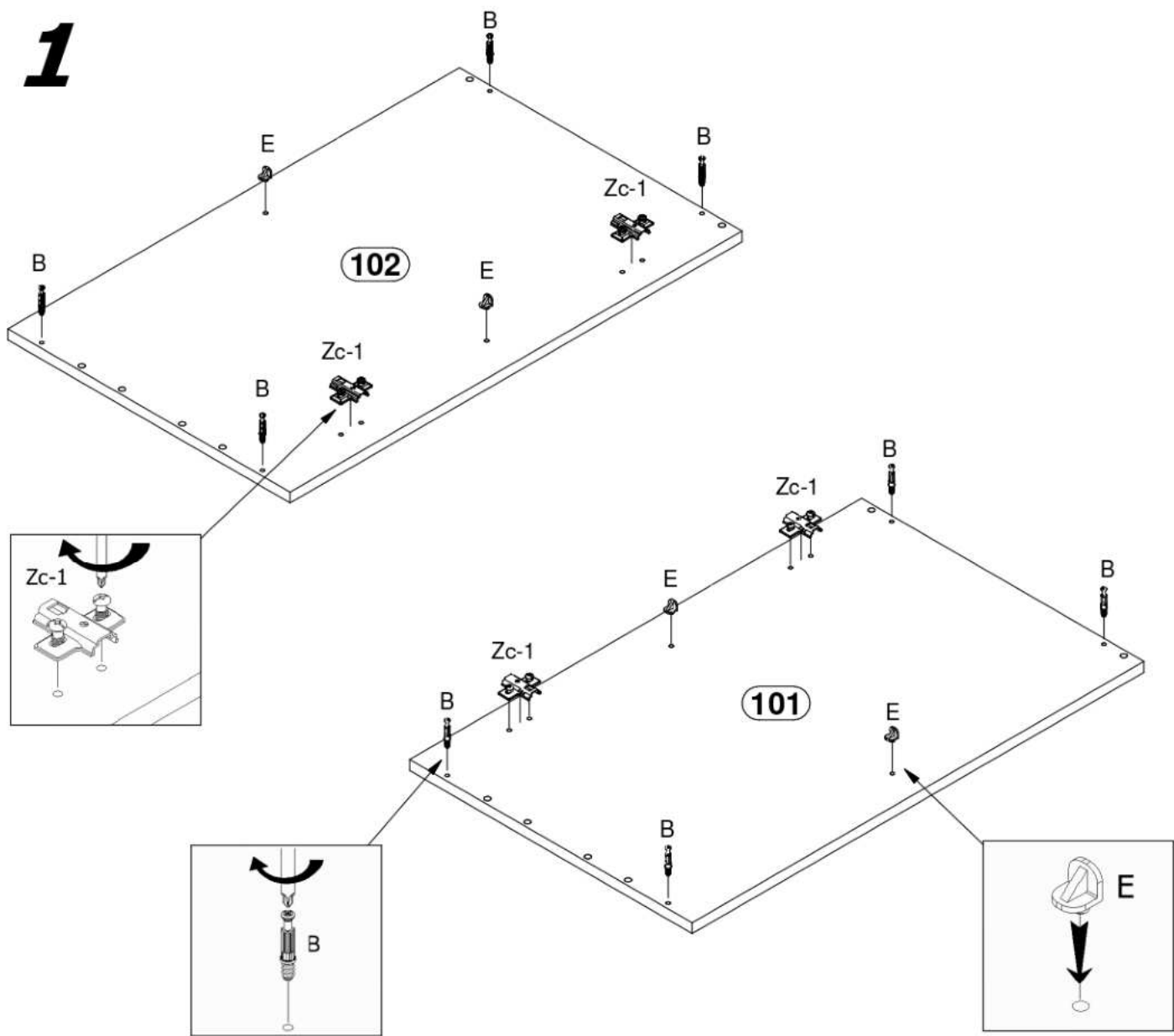

2

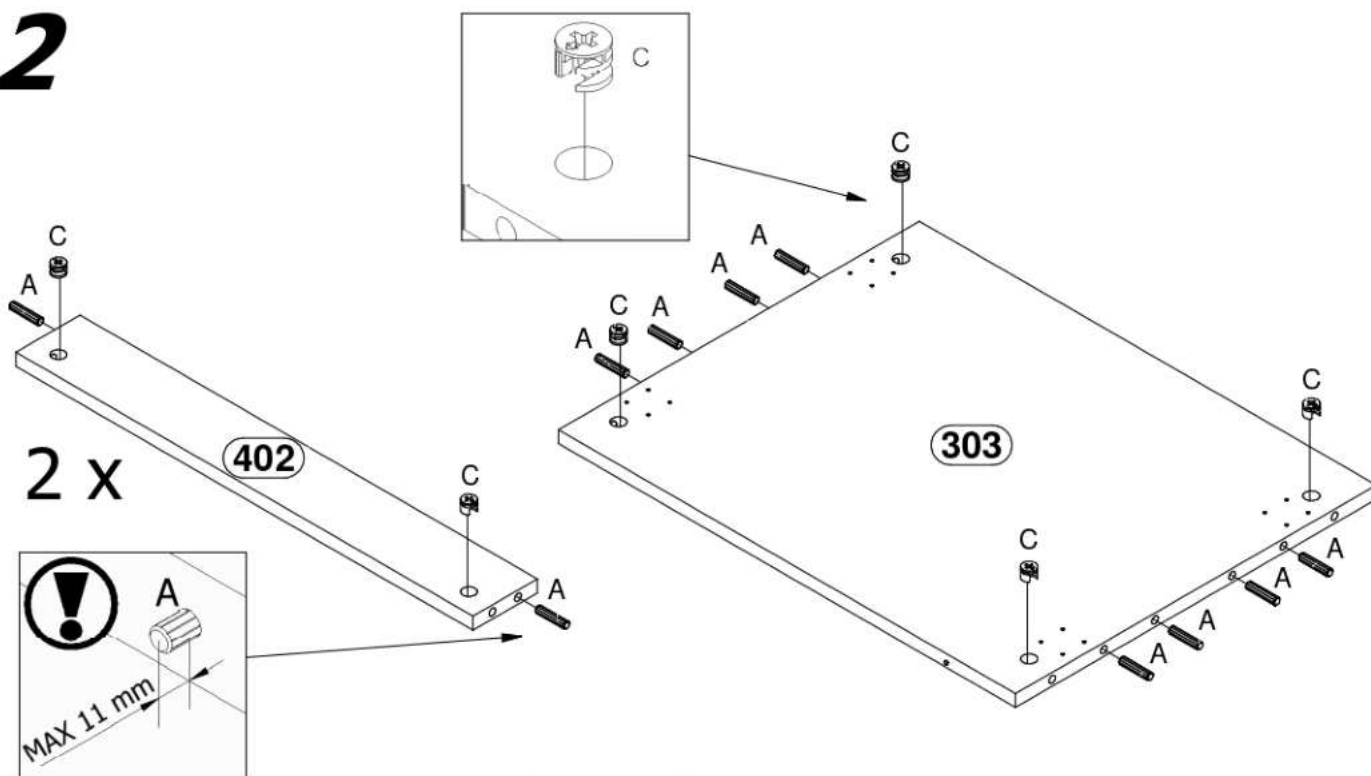

3

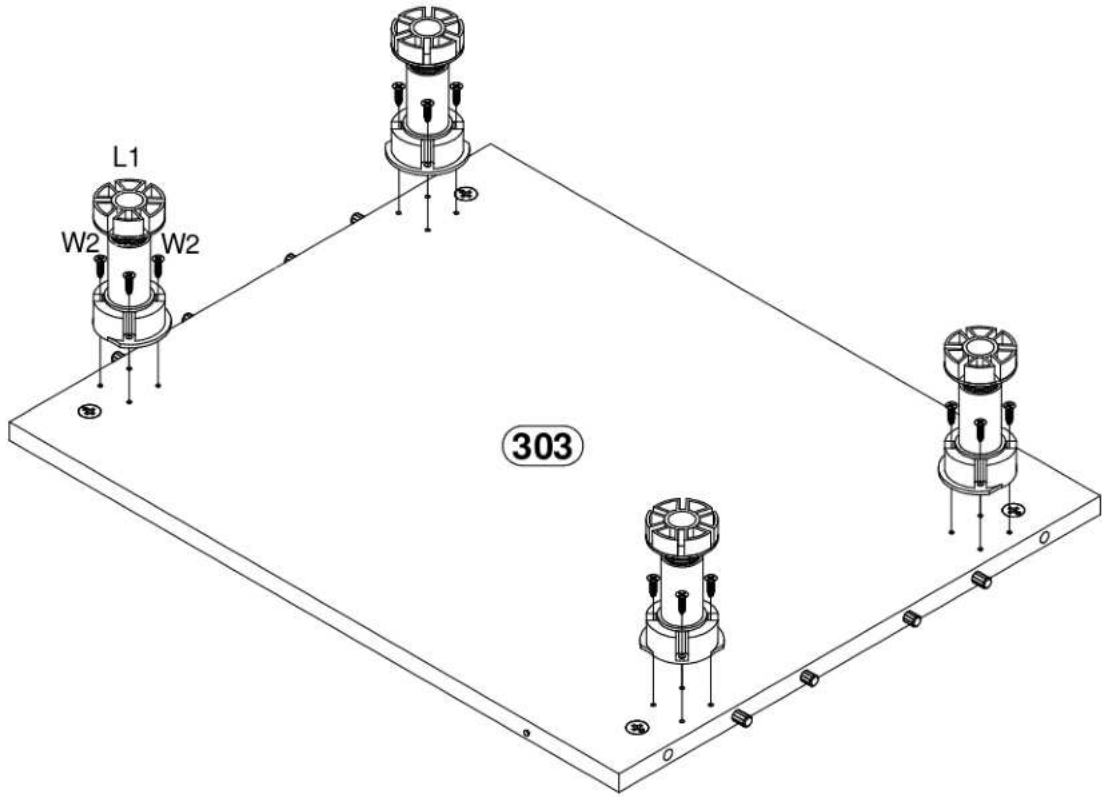

4

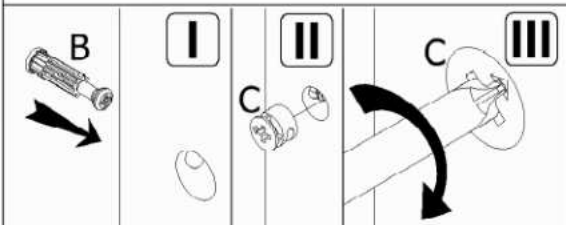
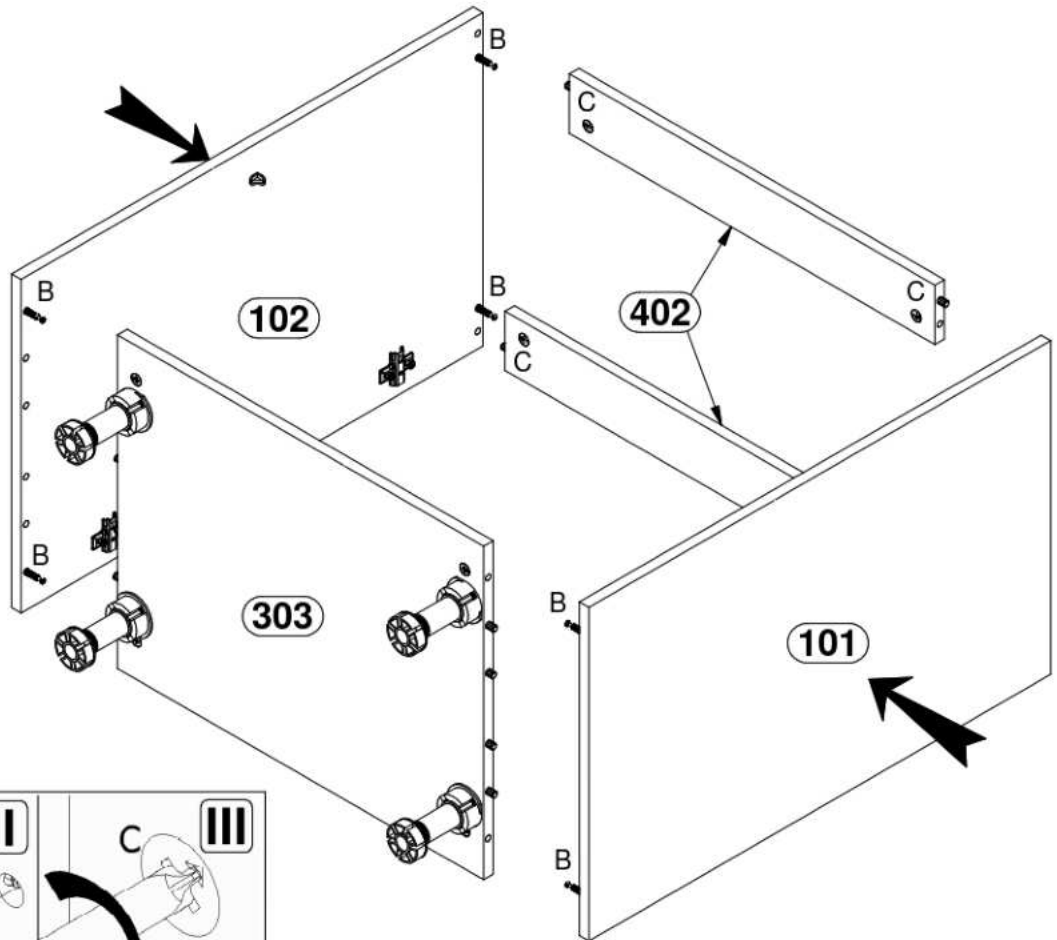

5

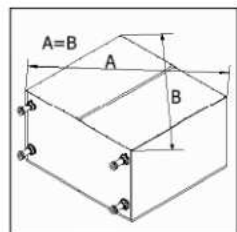
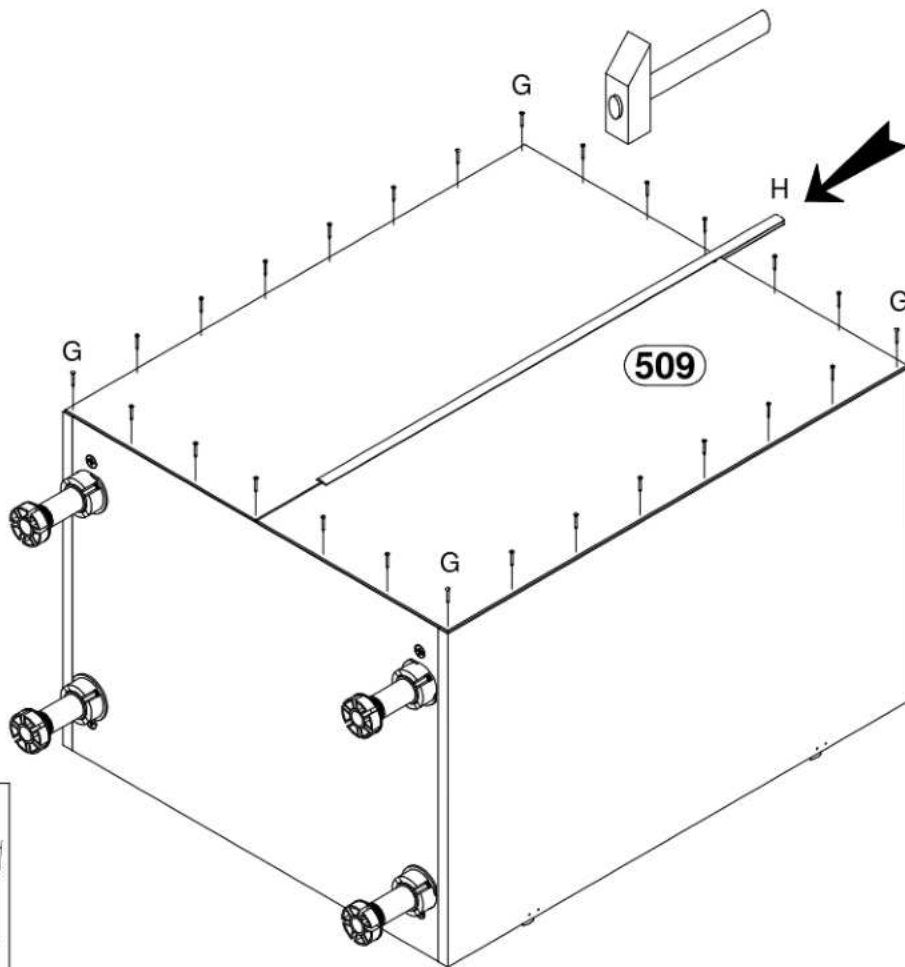

6

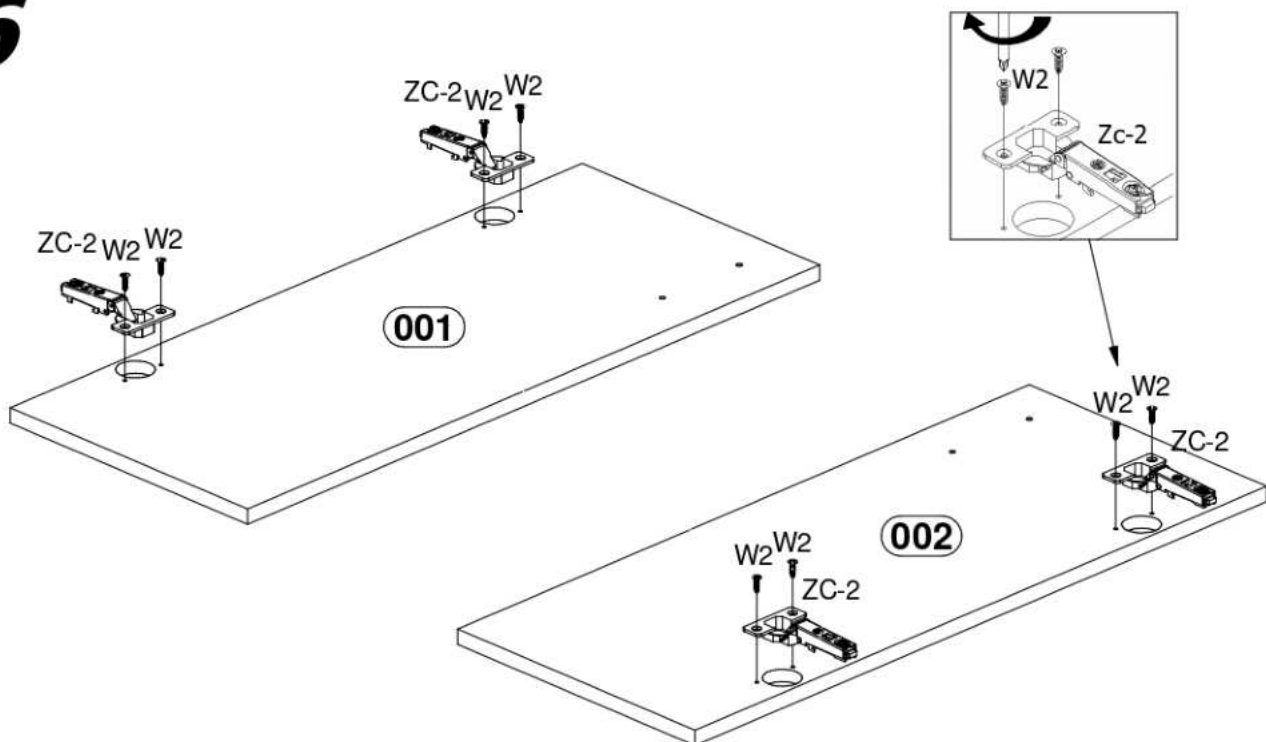

7

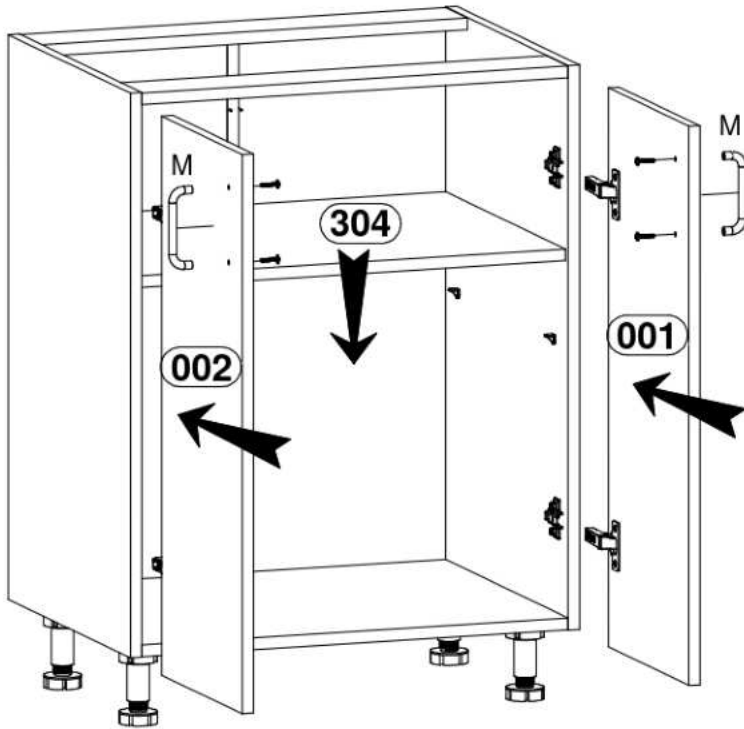

8

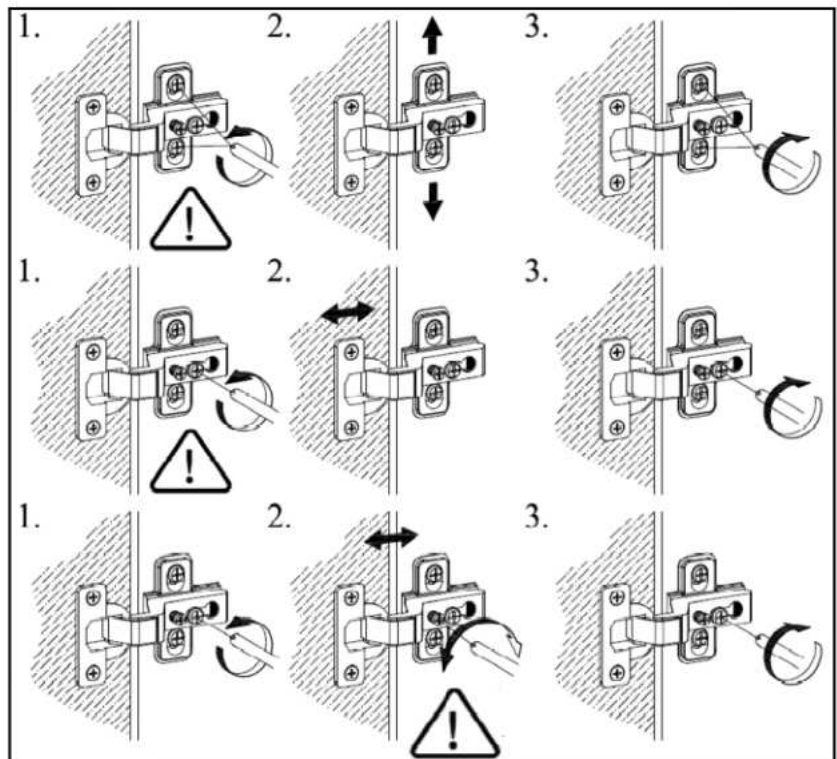

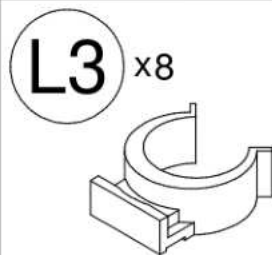
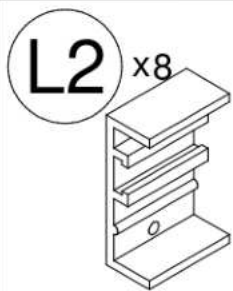
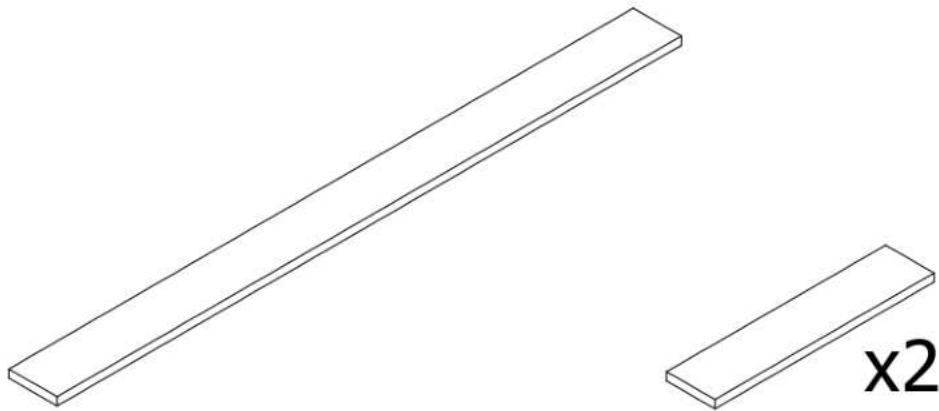
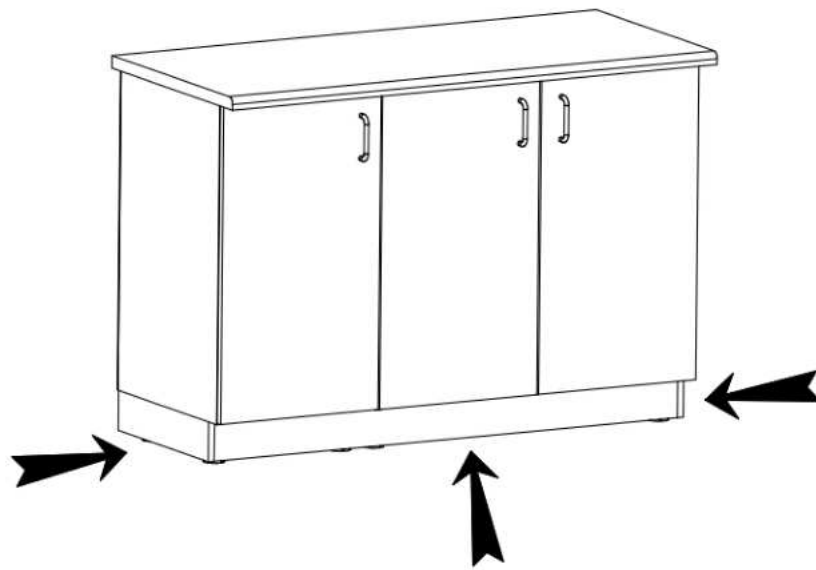

9

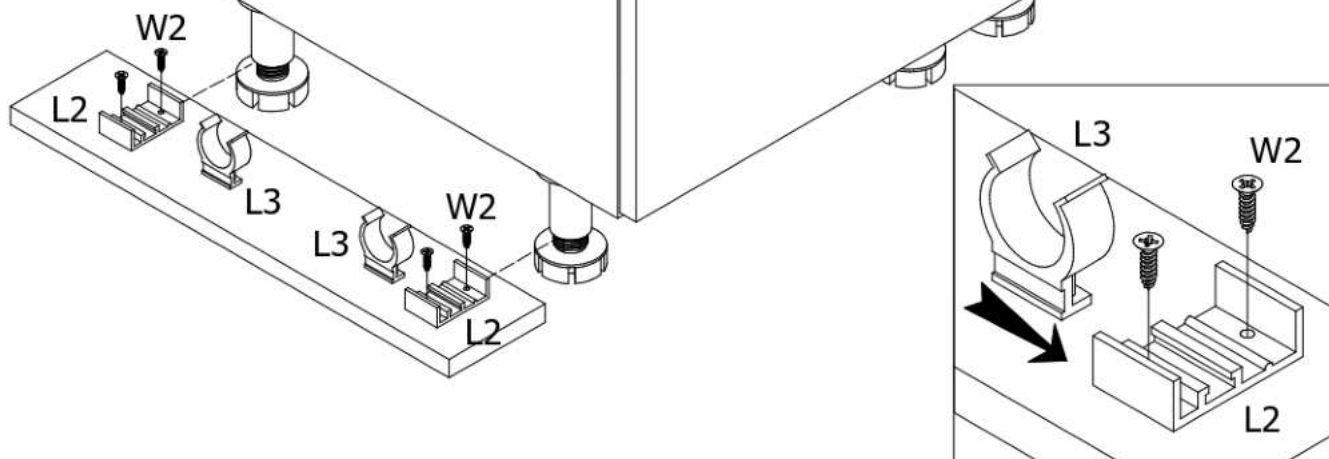

10

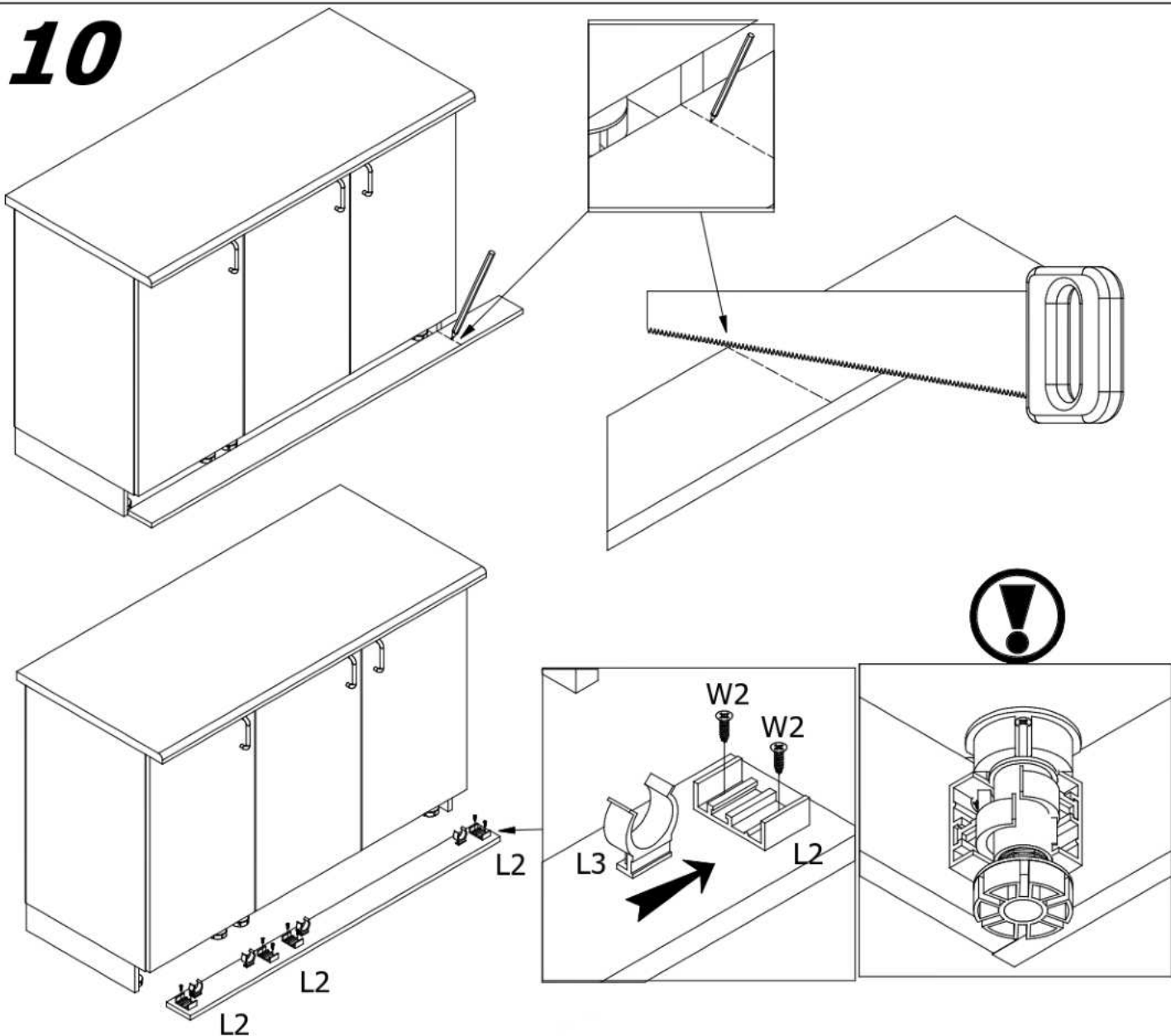

AURORA

D60P

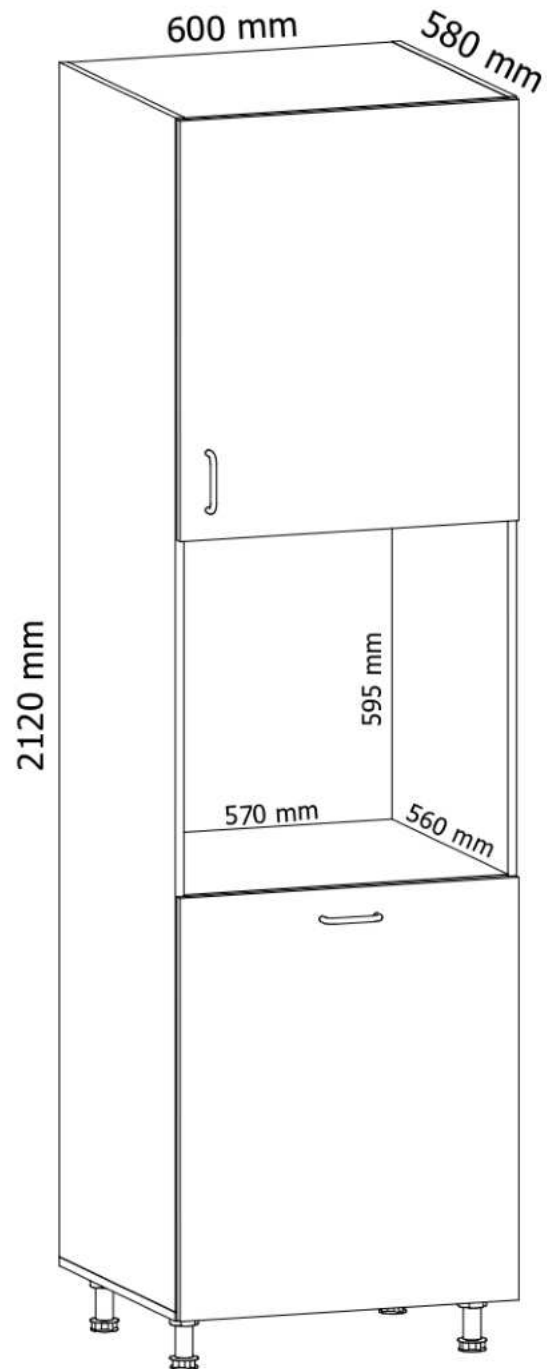

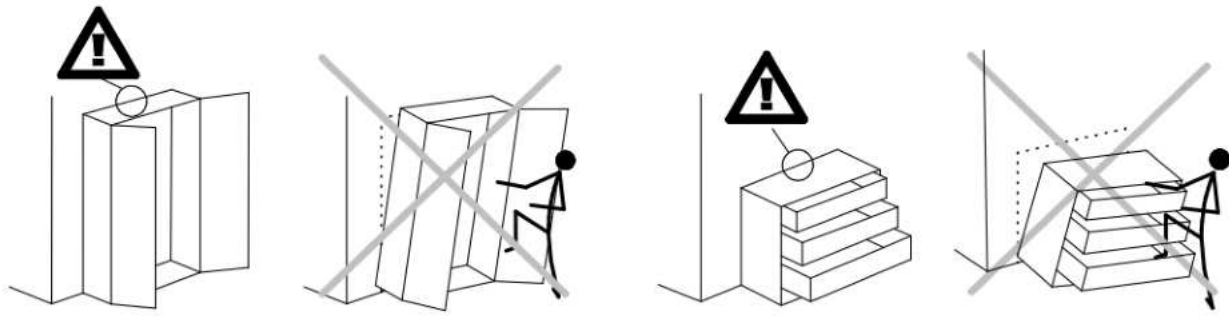

SK:

VÝSTRAHA PRED PREVRÁTENÍM!

Tento produkt musí byť natrvalo pripevnený k stene pomocou dodanej(-ých) konzoly (konzol), aby sa predišlo smrteľnému úrazu v prípade, že sa prevráti.

Balenie obsahuje iba skrutky, ktorými sa pripevňujú k produktu samotné konzoly chrániace pred prevrátaním. Kontaktujte miestnu predajňu pre domácich majstrov alebo železiarstvo, kde vám poradia ohľadom správneho typu skrutiek/príchytiiek pre váš typ steny.

CZ:

VAROVÁNÍ TÝKAJÍCÍ SE SKLOPENÍ!

Tento výrobek musí být trvale připevněn na stěnu pomocí přiložených držáků, aby nedošlo ke smrtelnému zranění, kdyby se sklopil. Sada obsahuje pouze šroubky pro upevnění držáků zabraňujících sklopení k výrobku. Ohledně správného typu vrutů/hmoždinek pro daný typ stěny se obraťte na vhodný obchod nebo železářství.

HR:

UPOZORENJE O OPASNOSTI OD PADA!

Ovaj proizvod mora stalno da bude pričvršćen za zid držačem (držačima) iz pakovanja, da bi se izbegla smrtonosna povreda u slučaju da proizvod padne.

Pakovanje sadrži samo šrafove za pričvršćavanje na proizvod držača protiv padanja. Kontaktirajte prodavnicu "Uradi sam" ili gvoždarsku radnju za savet o ispravnoj vrsti šrafova/tiplova za tip zida koji imate.

RO:

ATENȚIONATE RISC RĂSTURNARE!

Acest produs trebuie să fie atașat permanent de perete folosind suportului(rilor) furnizat(e) pentru a preveni rănirea mortală în cazul în care se răstoarnă.

Pachetul conține doar șuruburi, care sunt folosite pentru a atașa suporturile anti-răsturnare de produs. Contactați magazinul local de bricolaj sau magazinul de fierărie pentru sfaturi despre tipul corect de șuruburi/dibluri pentru tipul dumneavoastră de perete.

SI:

OPOZORILO PRED PREVRNITVIJO!

Ta izdelek mora biti trajno pritrjen na steno s pomočjo priloženih nosilcev, da se preprečijo smrtne poškodbe v primeru prevrnitve.

Paket vsebuje samo vijake, s katerimi se na izdelek pritrdijo sami nosilci za zaščito pred prevrnitvijo. Za nasvet o pravilni vrsti vijakov/vijakov za vaš tip stene se obrnite na lokalno trgovino z gradbenimi pripomočki.

HU:

FELBORULÁSRA VONATKOZÓ FIGYELMEZTETÉS!

Ezt a terméket tartósan a falhoz kell rögzíteni a mellékelt konzol(ok) segítségével, hogy elkerülje a halálos sérülést felborulás esetén.

A csomag csak csavarokat tartalmaz, amelyekkel a borulásgátló konzolokat rögzítik a termékhez. Forduljon a helyi lakberendezési bolthoz vagy hardverbolthoz, hogy tanácsot kapjon az Ön faltípusának megfelelő csavarok/kapcsok típusával kapcsolatban.

D60P

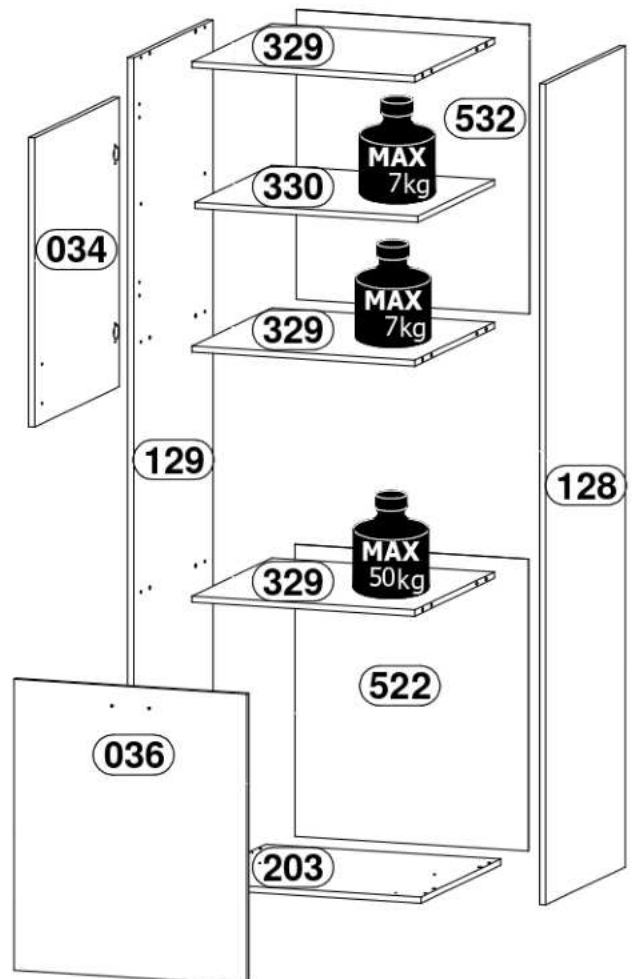
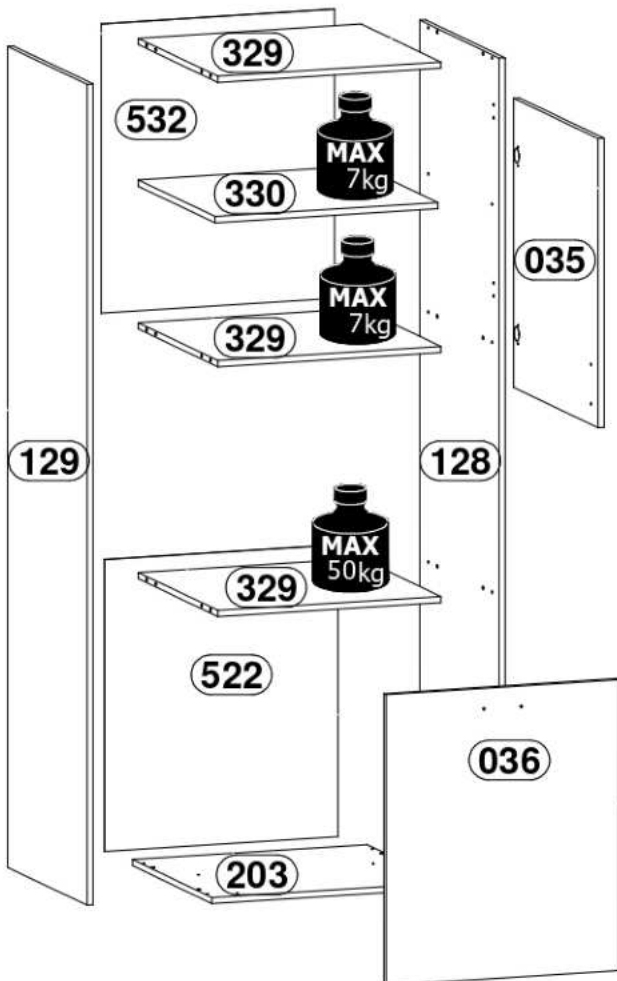
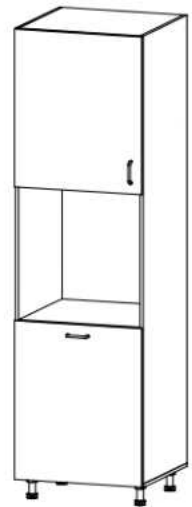
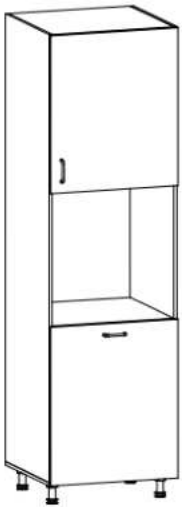

1

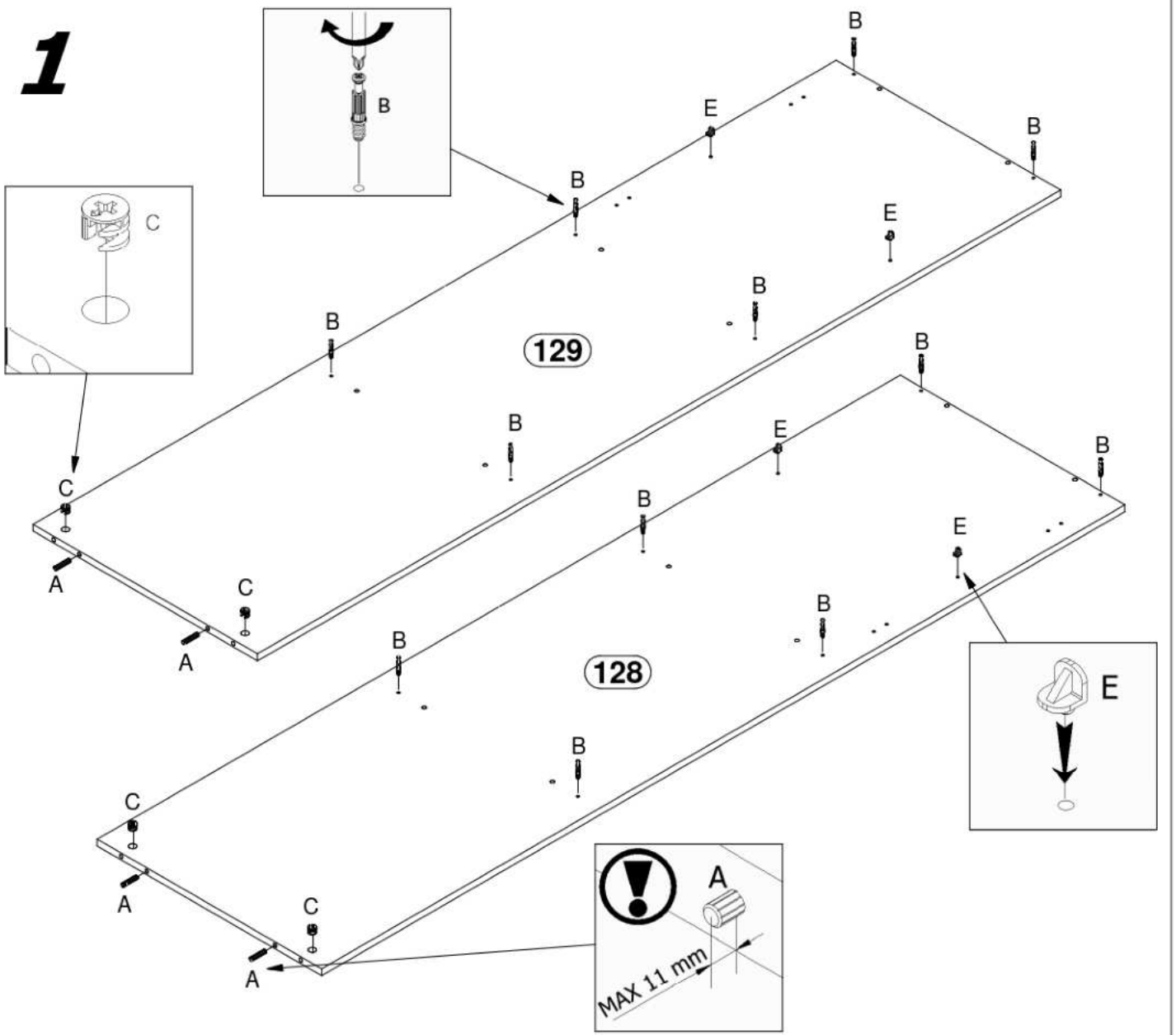

2

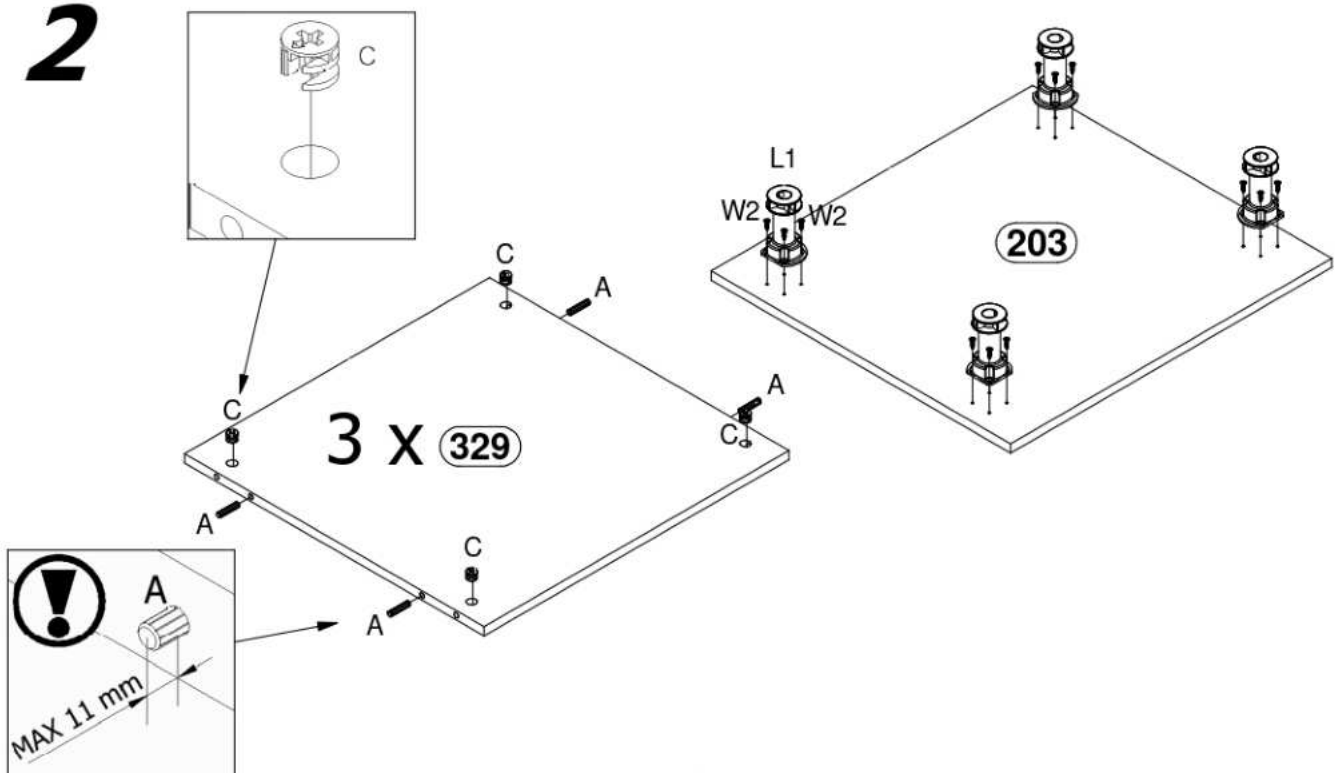

3

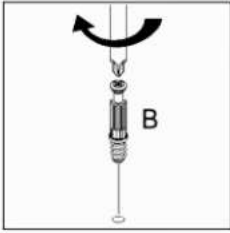
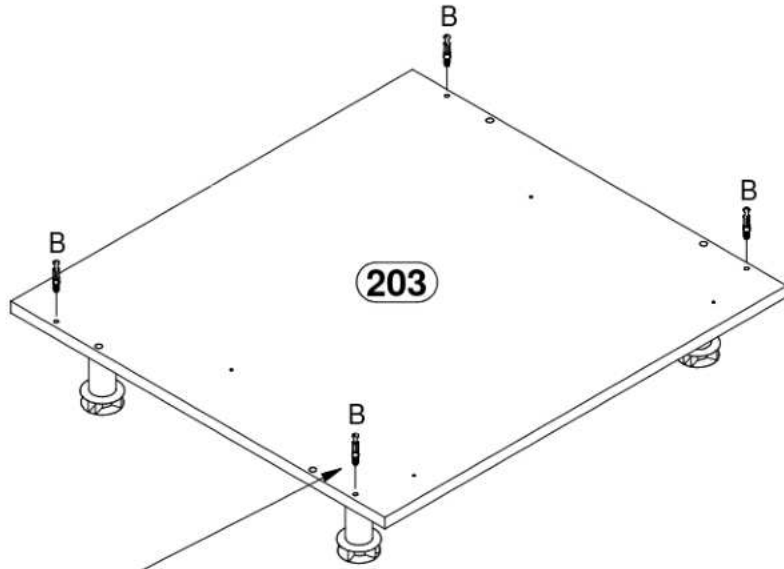

4

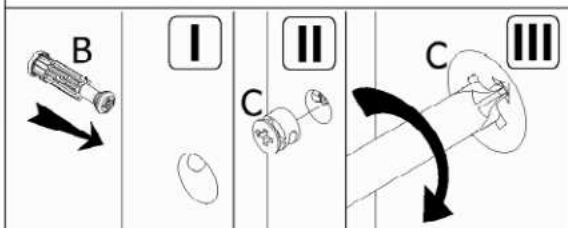
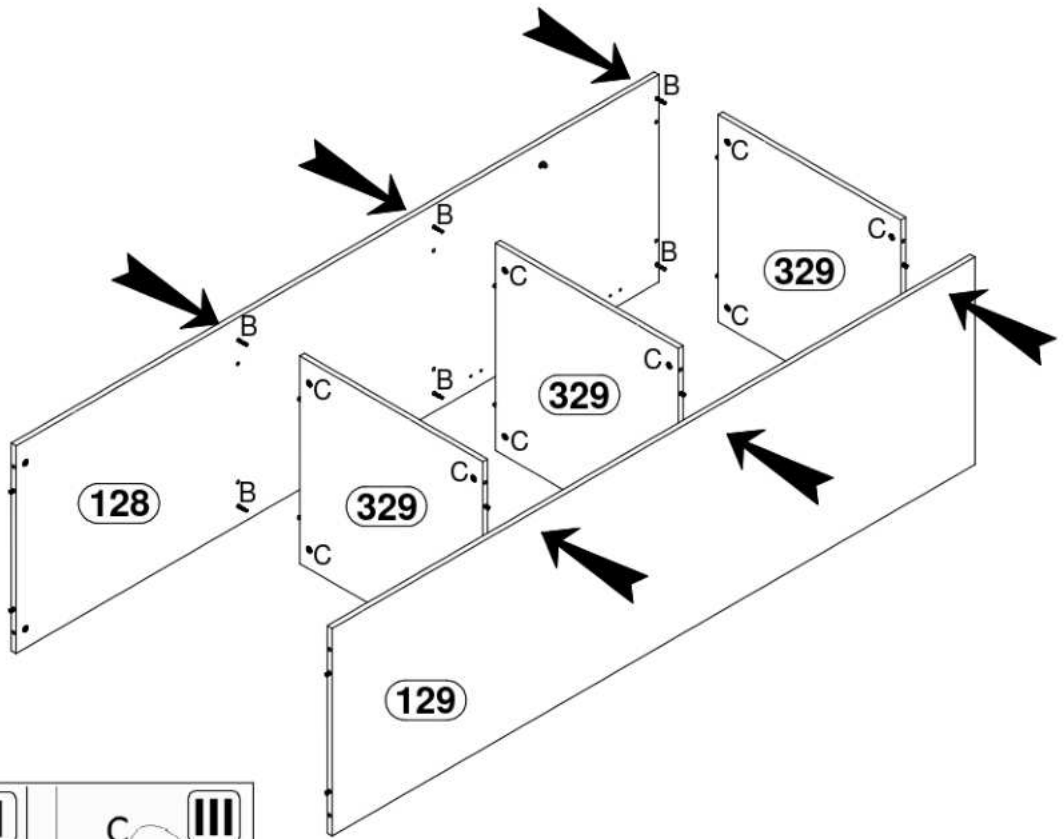

5

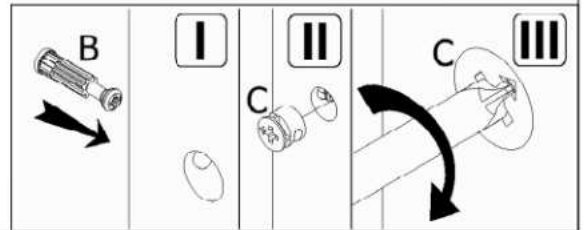
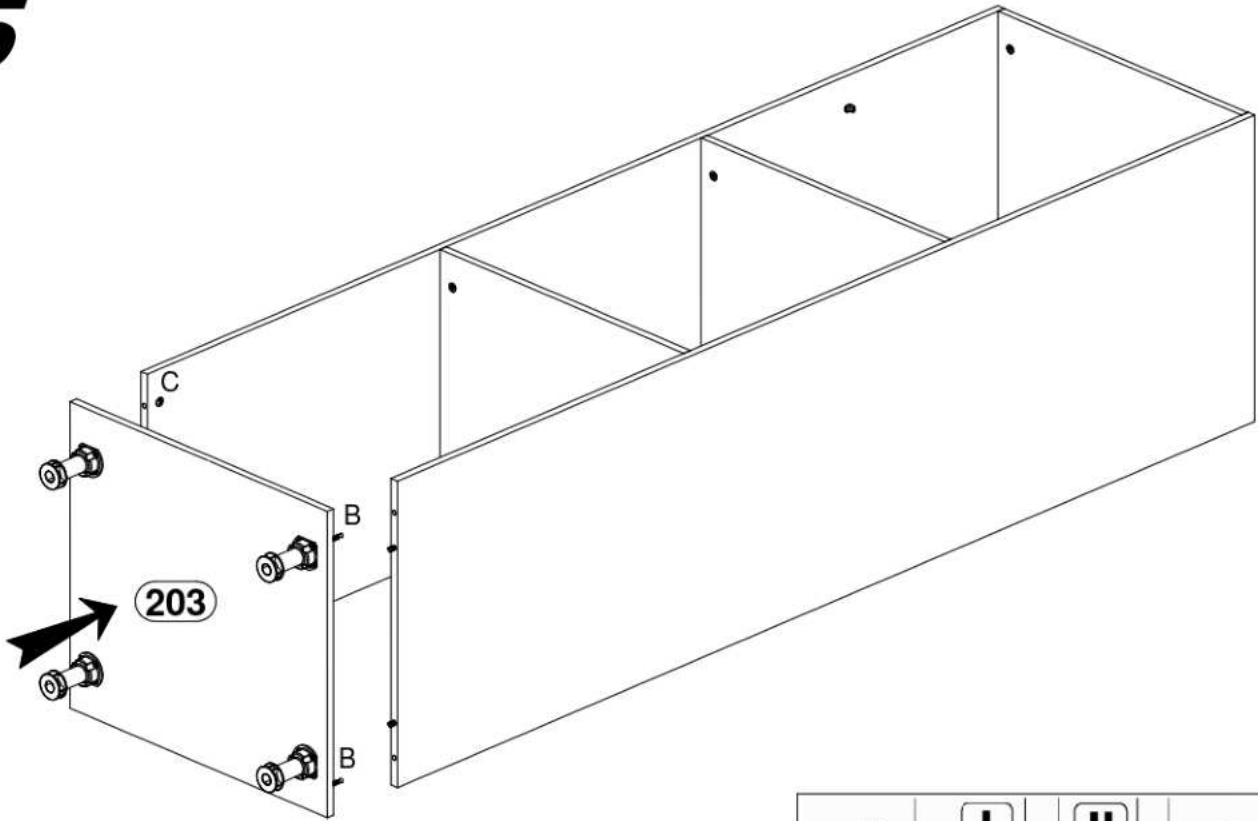

6

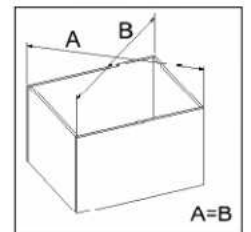
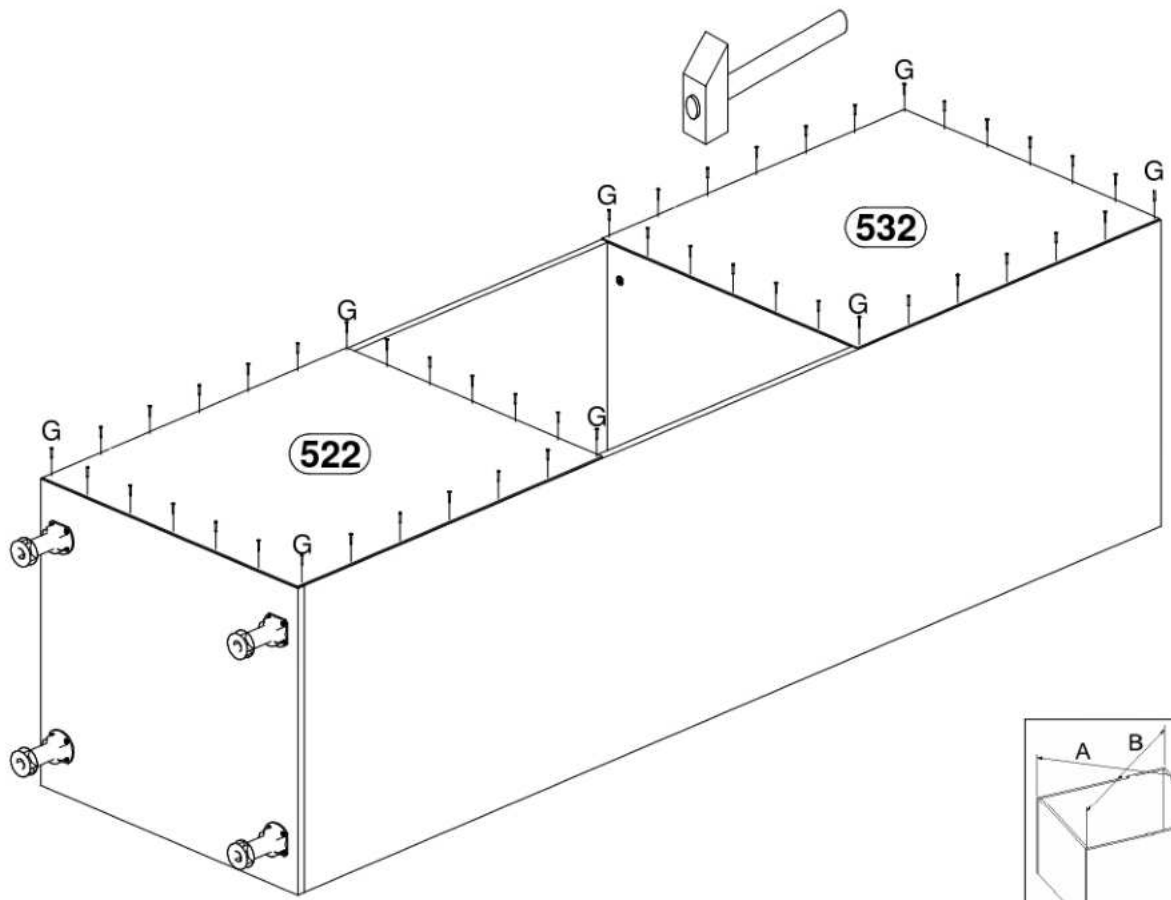

7

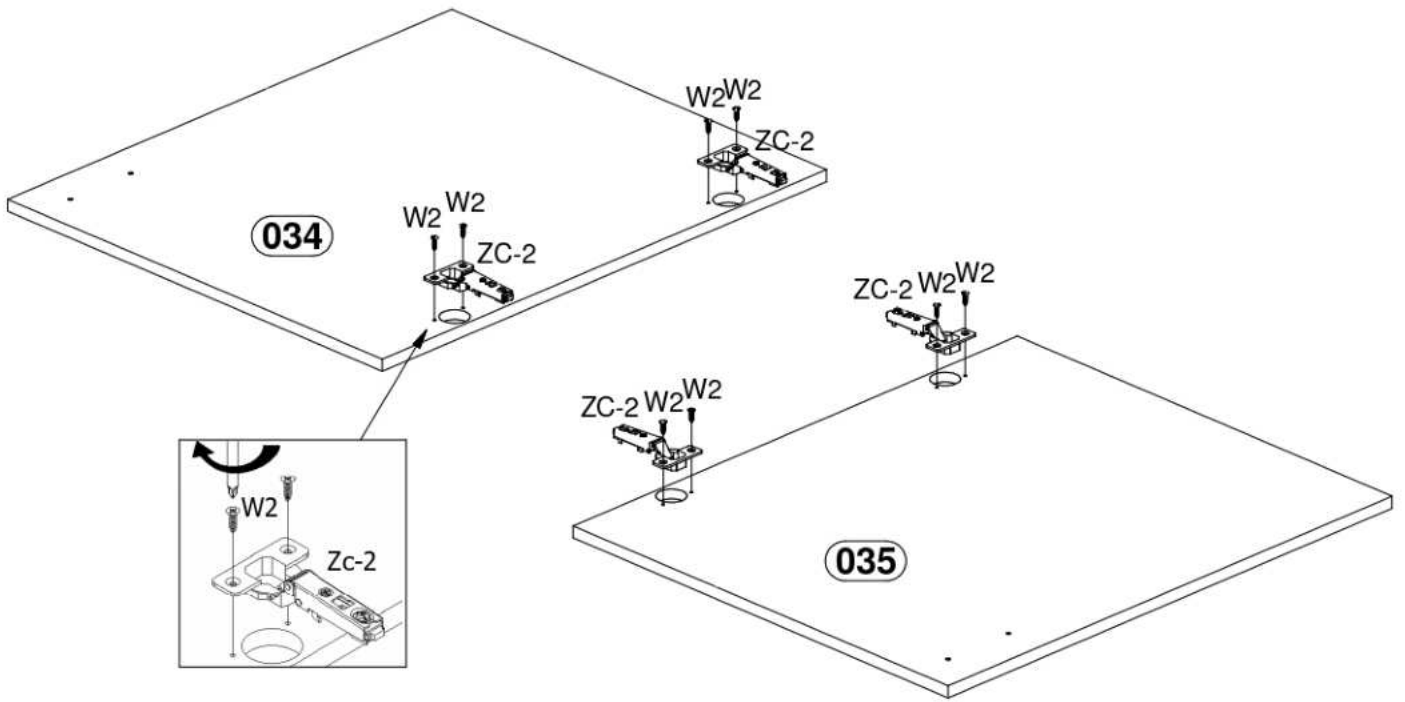

8

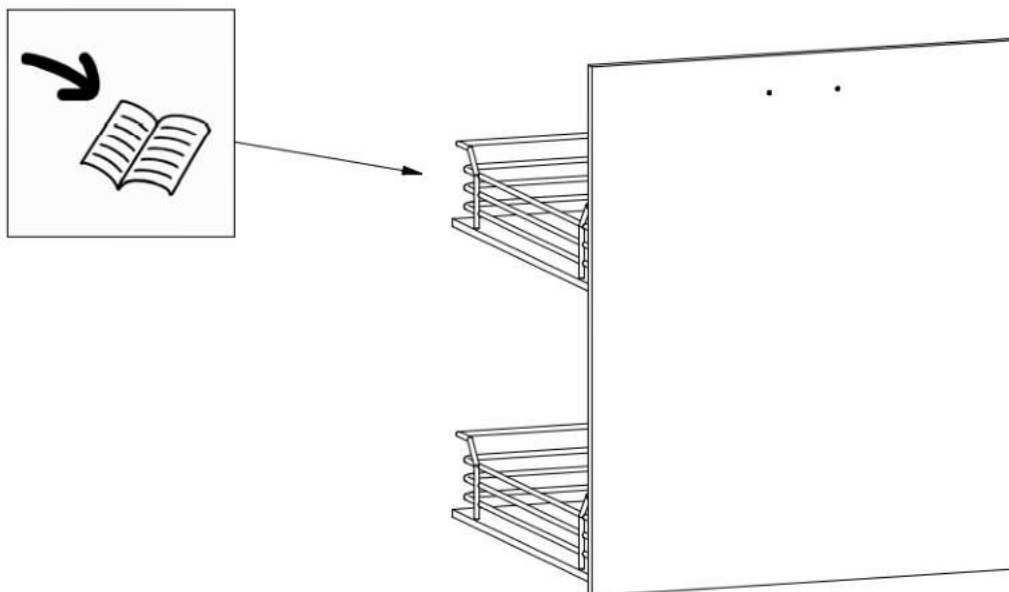

9

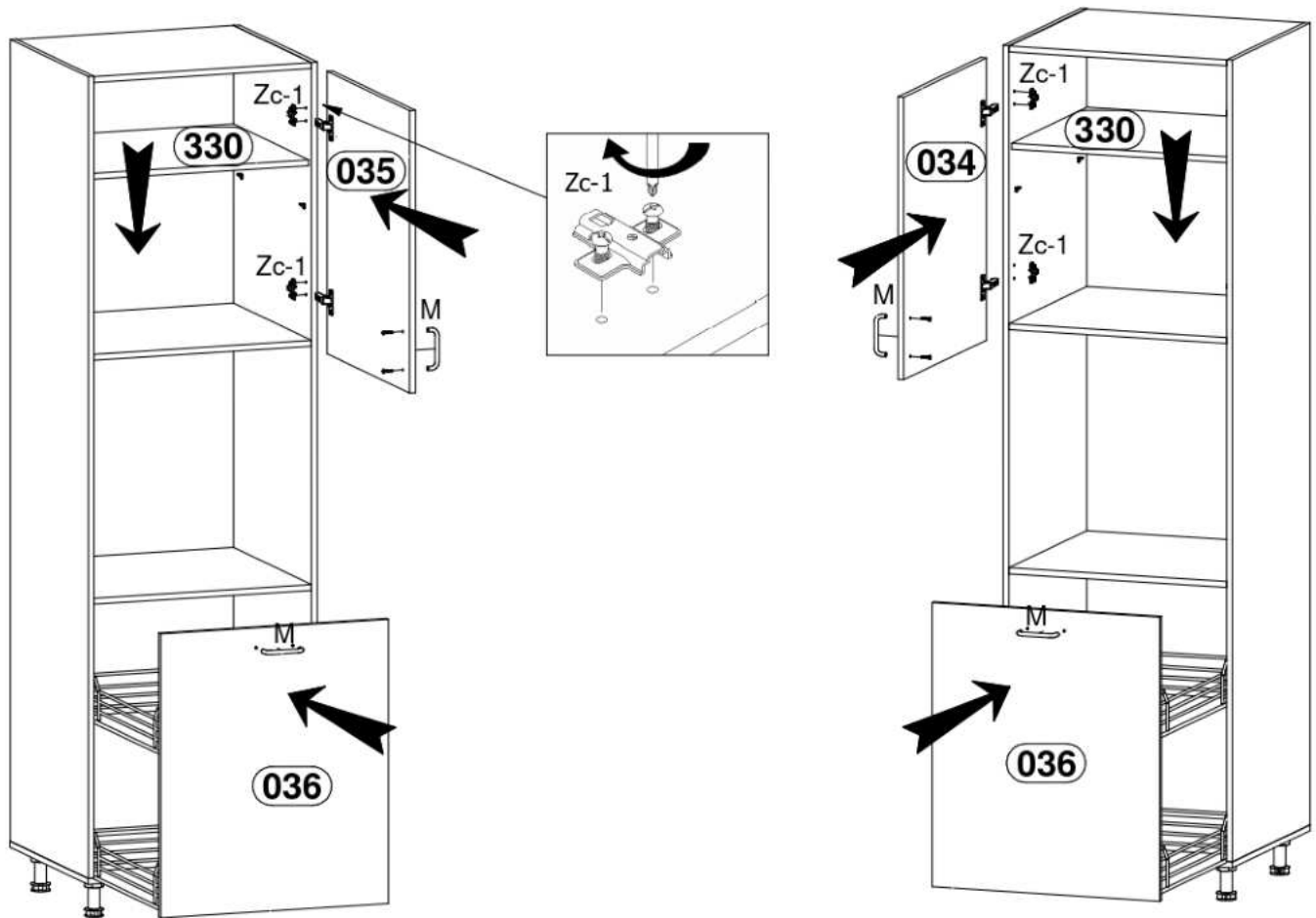

10

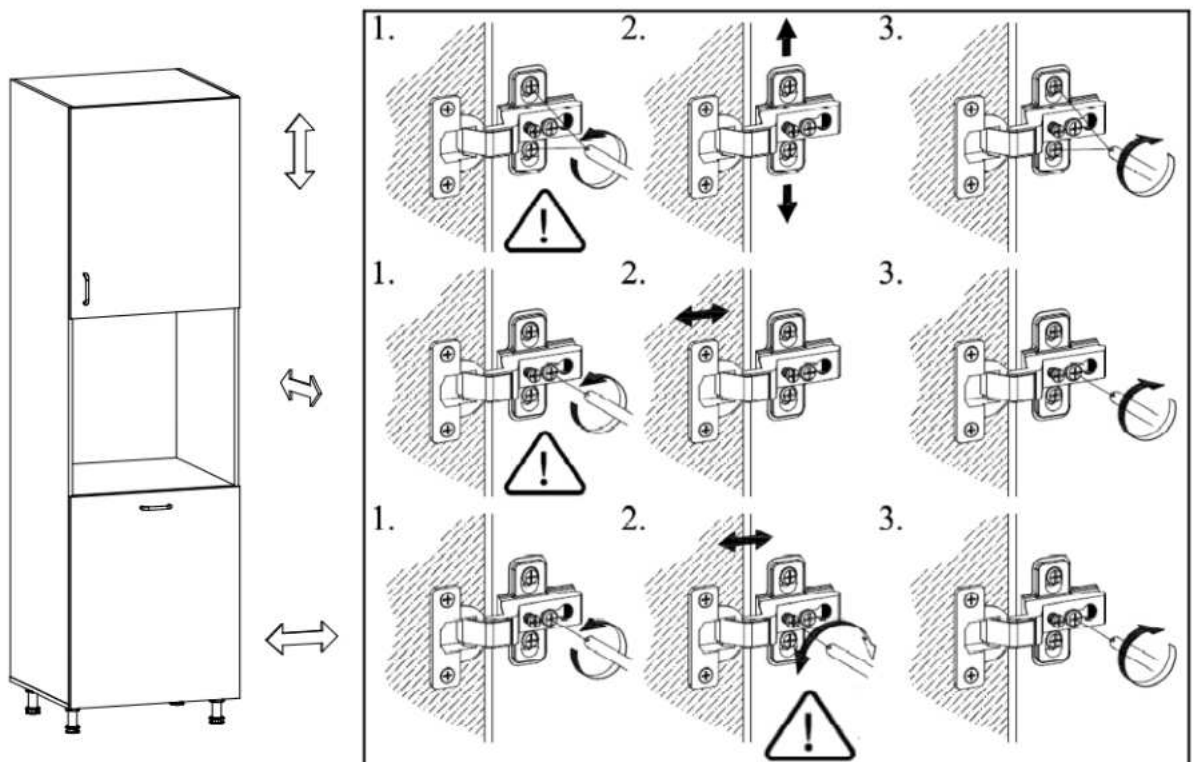

11

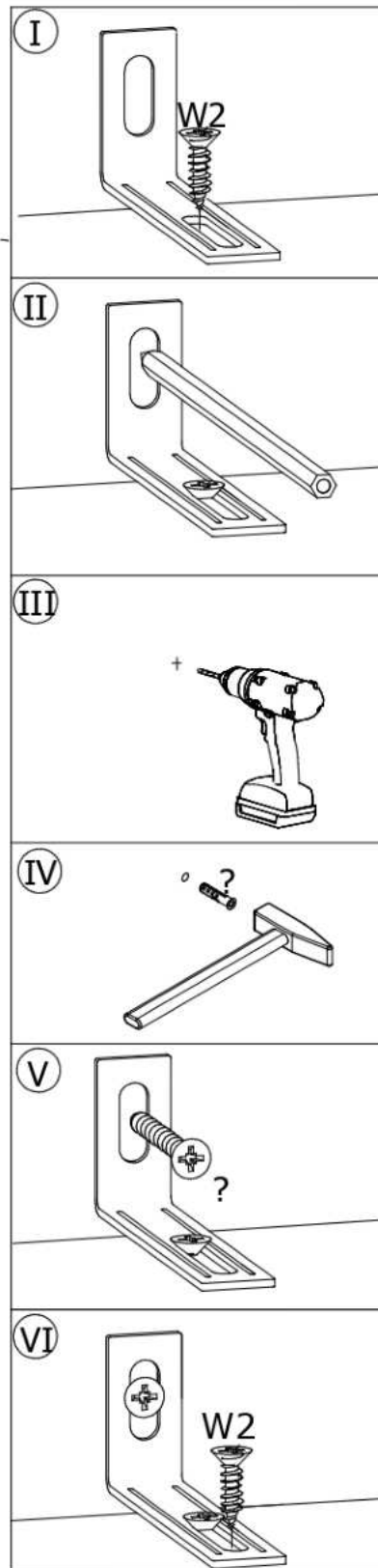
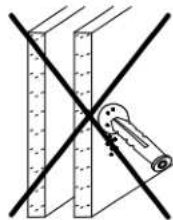
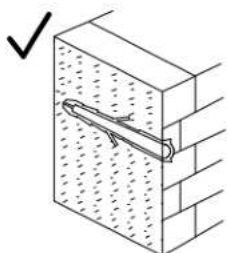
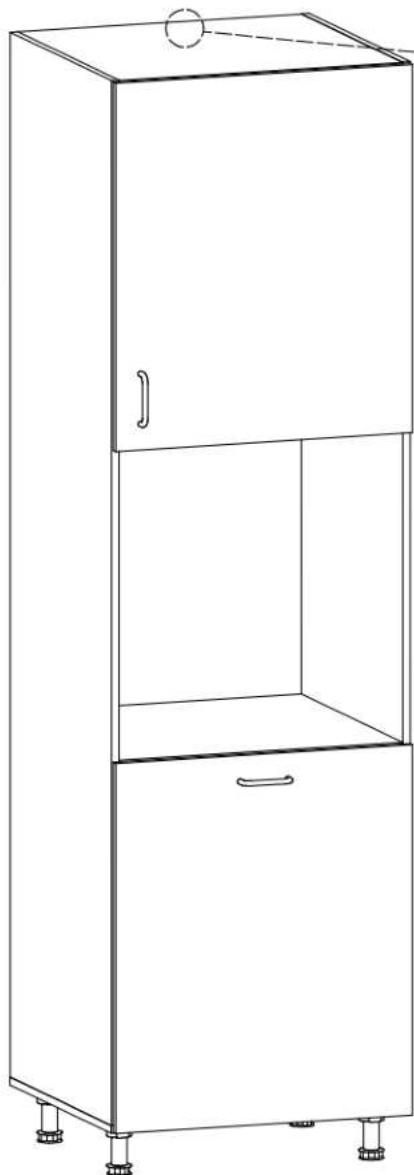
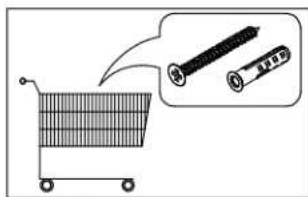
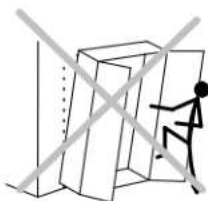
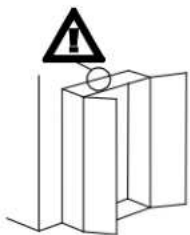

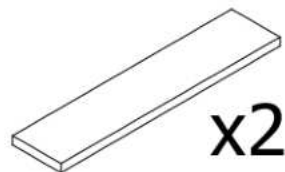
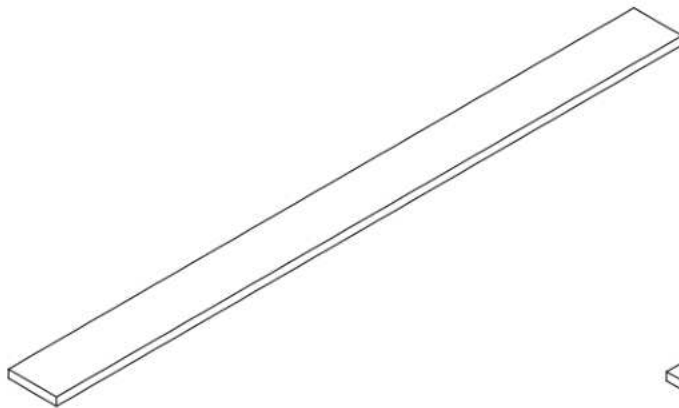
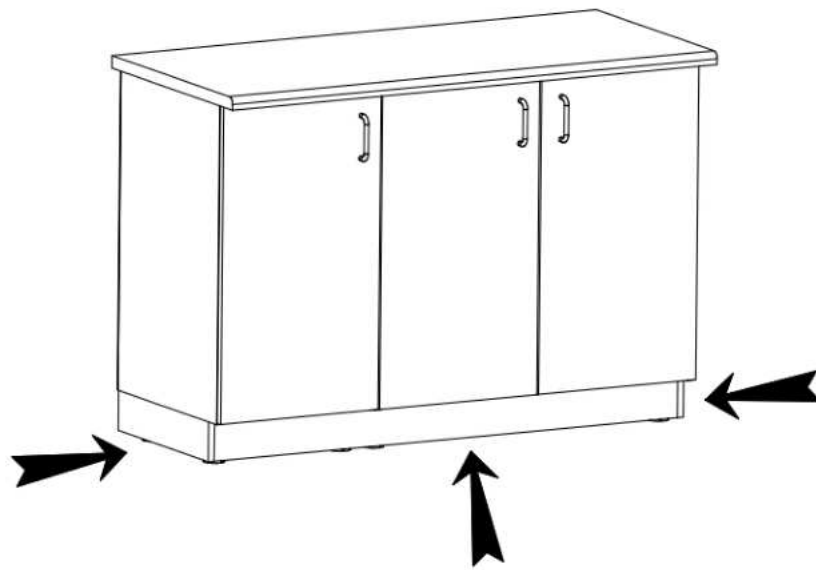

x2

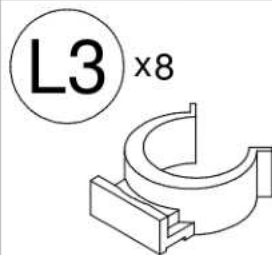
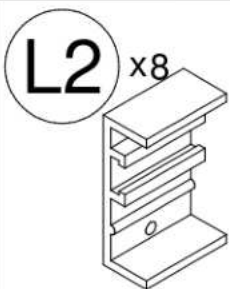

Ø3,5x16

12

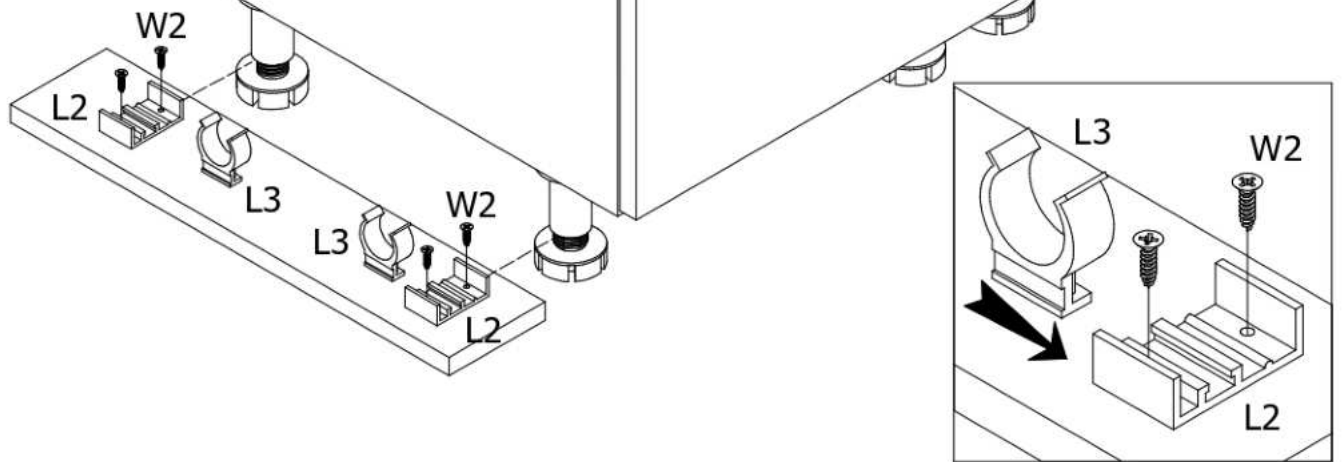

13

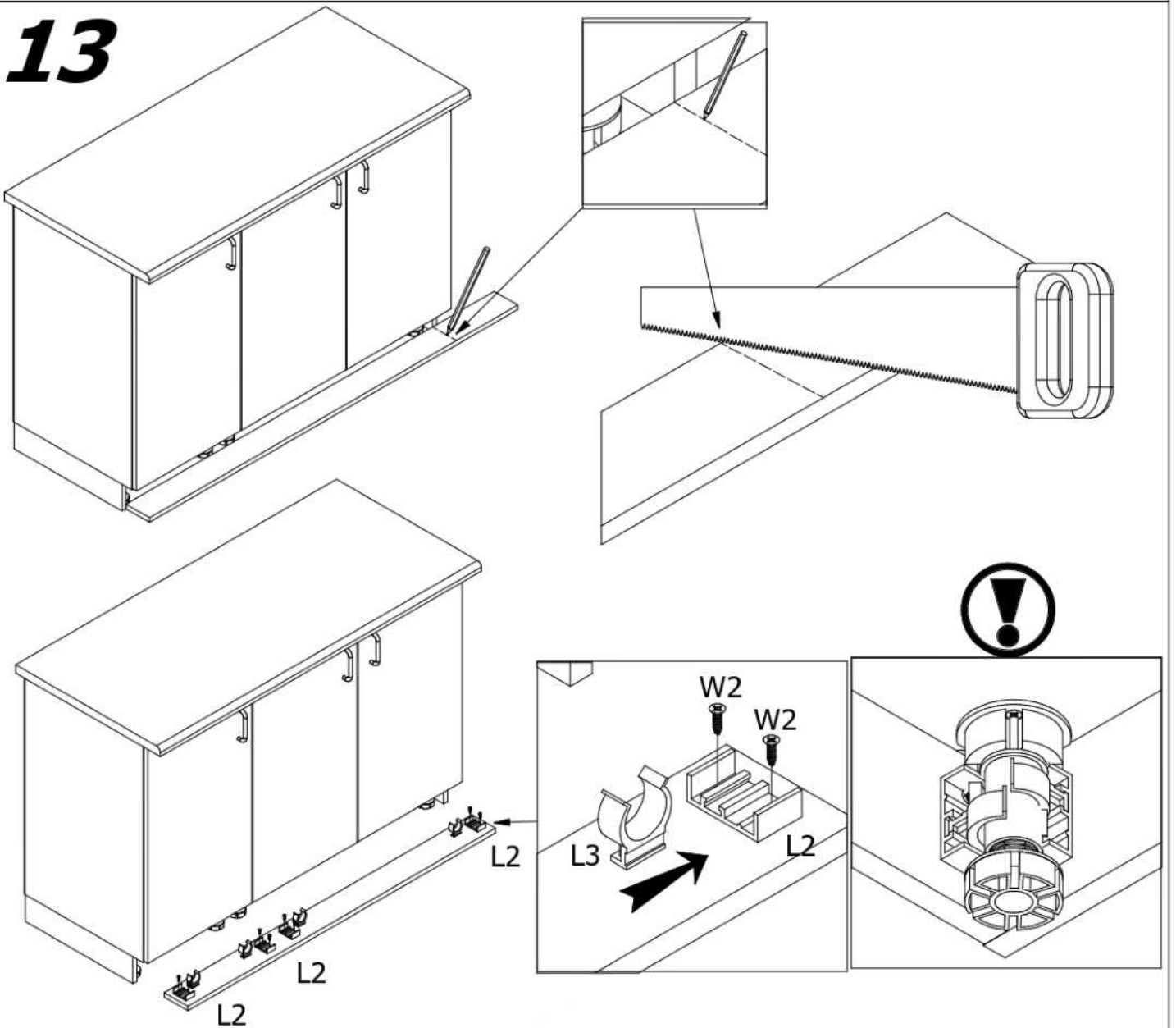

AURORA

D60R

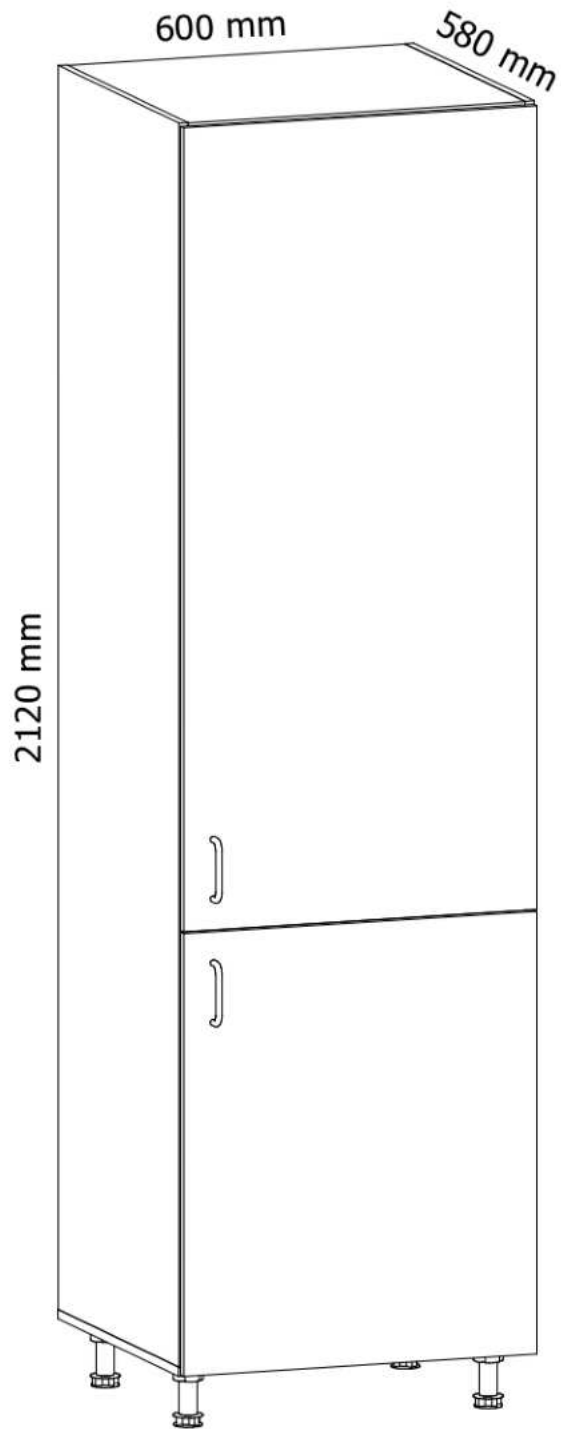

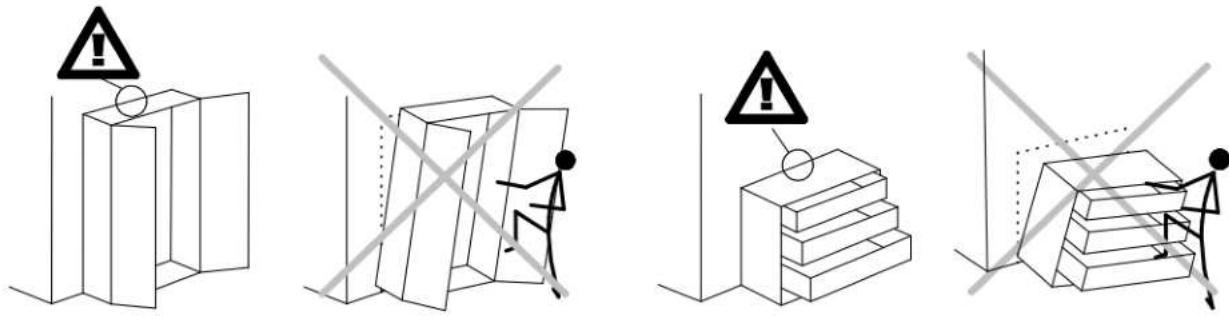

SK:

VÝSTRAHA PRED PREVRÁTENÍM!

Tento produkt musí byť natrvalo pripevnený k stene pomocou dodanej(-ých) konzoly (konzol), aby sa predišlo smrteľnému úrazu v prípade, že sa prevráti.

Balenie obsahuje iba skrutky, ktorými sa pripevňujú k produktu samotné konzoly chrániace pred prevrátaním. Kontaktujte miestnu predajňu pre domácich majstrov alebo železiarstvo, kde vám poradia ohľadom správneho typu skrutiek/príchytiiek pre váš typ steny.

CZ:

VAROVÁNÍ TÝKAJÍCÍ SE SKLOPENÍ!

Tento výrobek musí být trvale připevněn na stěnu pomocí přiložených držáků, aby nedošlo ke smrtelnému zranění, kdyby se sklopil. Sada obsahuje pouze šroubky pro upevnění držáků zabraňujících sklopení k výrobku. Ohledně správného typu vrutů/hmoždinek pro daný typ stěny se obraťte na vhodný obchod nebo železářství.

HR:

UPOZORENJE O OPASNOSTI OD PADA!

Ovaj proizvod mora stalno da bude pričvršćen za zid držačem (držačima) iz pakovanja, da bi se izbegla smrtonosna povreda u slučaju da proizvod padne.

Pakovanje sadrži samo šrafove za pričvršćavanje na proizvod držača protiv padanja. Kontaktirajte prodavnicu "Uradi sam" ili gvoždarsku radnju za savet o ispravnoj vrsti šrafova/tiplova za tip zida koji imate.

RO:

ATENȚIONATE RISC RĂSTURNARE!

Acest produs trebuie să fie atașat permanent de perete folosind suportului(rilor) furnizat(e) pentru a preveni rănirea mortală în cazul în care se răstoarnă.

Pachetul conține doar șuruburi, care sunt folosite pentru a atașa suporturile anti-răsturnare de produs. Contactați magazinul local de bricolaj sau magazinul de fierărie pentru sfaturi despre tipul corect de șuruburi/dibluri pentru tipul dumneavoastră de perete.

SI:

OPOZORILO PRED PREVRNITVIJO!

Ta izdelek mora biti trajno pritrjen na steno s pomočjo priloženih nosilcev, da se preprečijo smrtne poškodbe v primeru prevrnitve.

Paket vsebuje samo vijake, s katerimi se na izdelek pritrdijo sami nosilci za zaščito pred prevrnitvijo. Za nasvet o pravilni vrsti vijakov/vijakov za vaš tip stene se obrnite na lokalno trgovino z gradbenimi pripomočki.

HU:









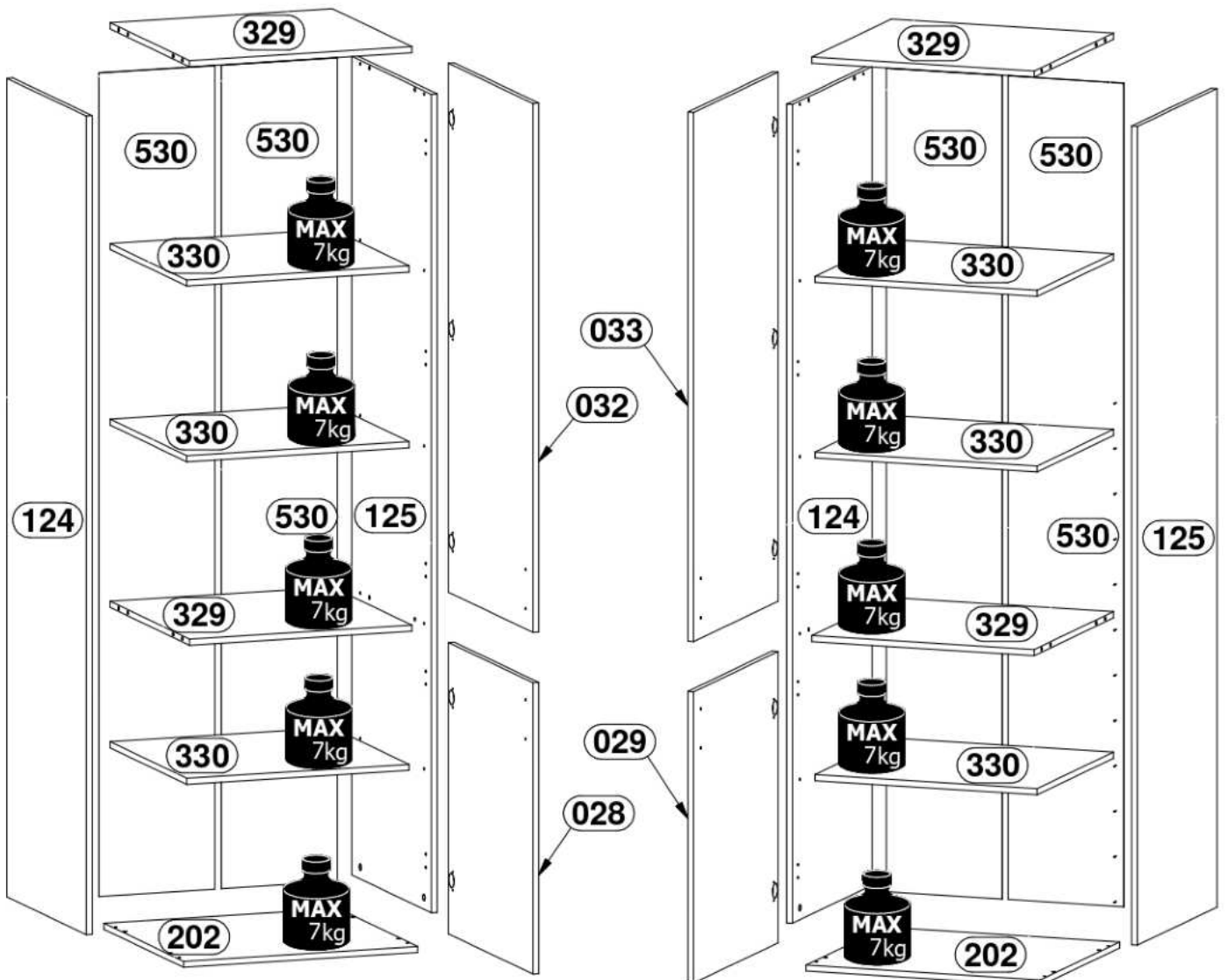
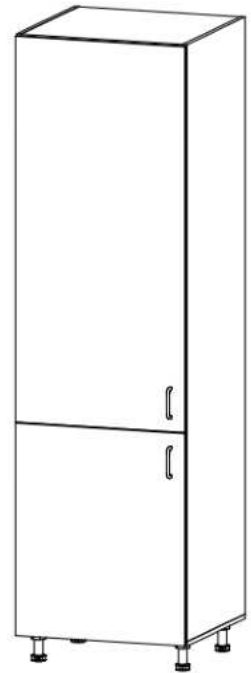
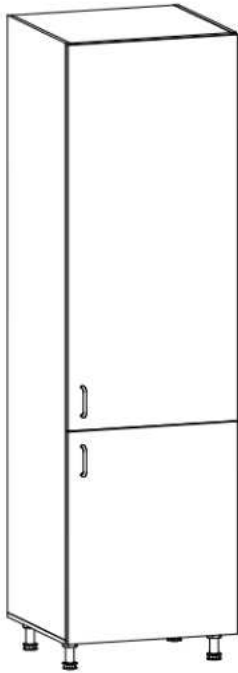

FELBORULÁSRA VONATKOZÓ FIGYELMEZTETÉS!

Ezt a terméket tartósan a falhoz kell rögzíteni a mellékelt konzol(ok) segítségével, hogy elkerülje a halálos sérülést felborulás esetén.

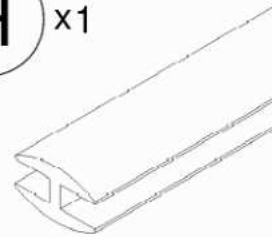
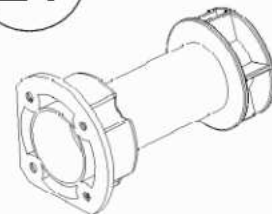
A csomag csak csavarokat tartalmaz, amelyekkel a borulásgátló konzolokat rögzítik a termékhez. Forduljon a helyi lakberendezési bolthoz vagy hardverbolthoz, hogy tanácsot kapjon az Ön faltípusának megfelelő csavarok/kapcsok típusával kapcsolatban.

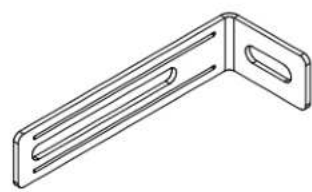
D60R

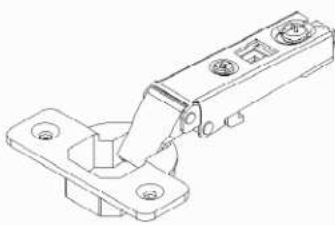

<p>A x12</p>  <p>Ø8x35mm</p>	<p>B x12</p> 	<p>C x12</p>  <p>Ø15x12mm</p>	<p>E x12</p> 
<p>G x40</p> 	<p>H x1</p>  <p>2015 mm</p>	<p>L1 x4</p> 	<p>M x2</p> 
<p>T4 x1</p>  <p>75x28x16 mm</p>	<p>W2 x28</p>  <p>Ø3,5x16mm</p>	<p>Y x12</p>  <p>Ø18 mm</p>	
<p>Zc x5</p>  <p>Zc-1</p>  <p>Zc-2</p>			

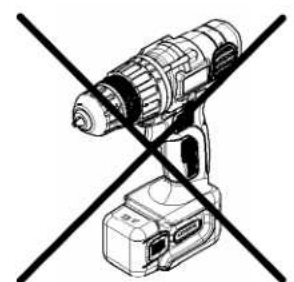

1

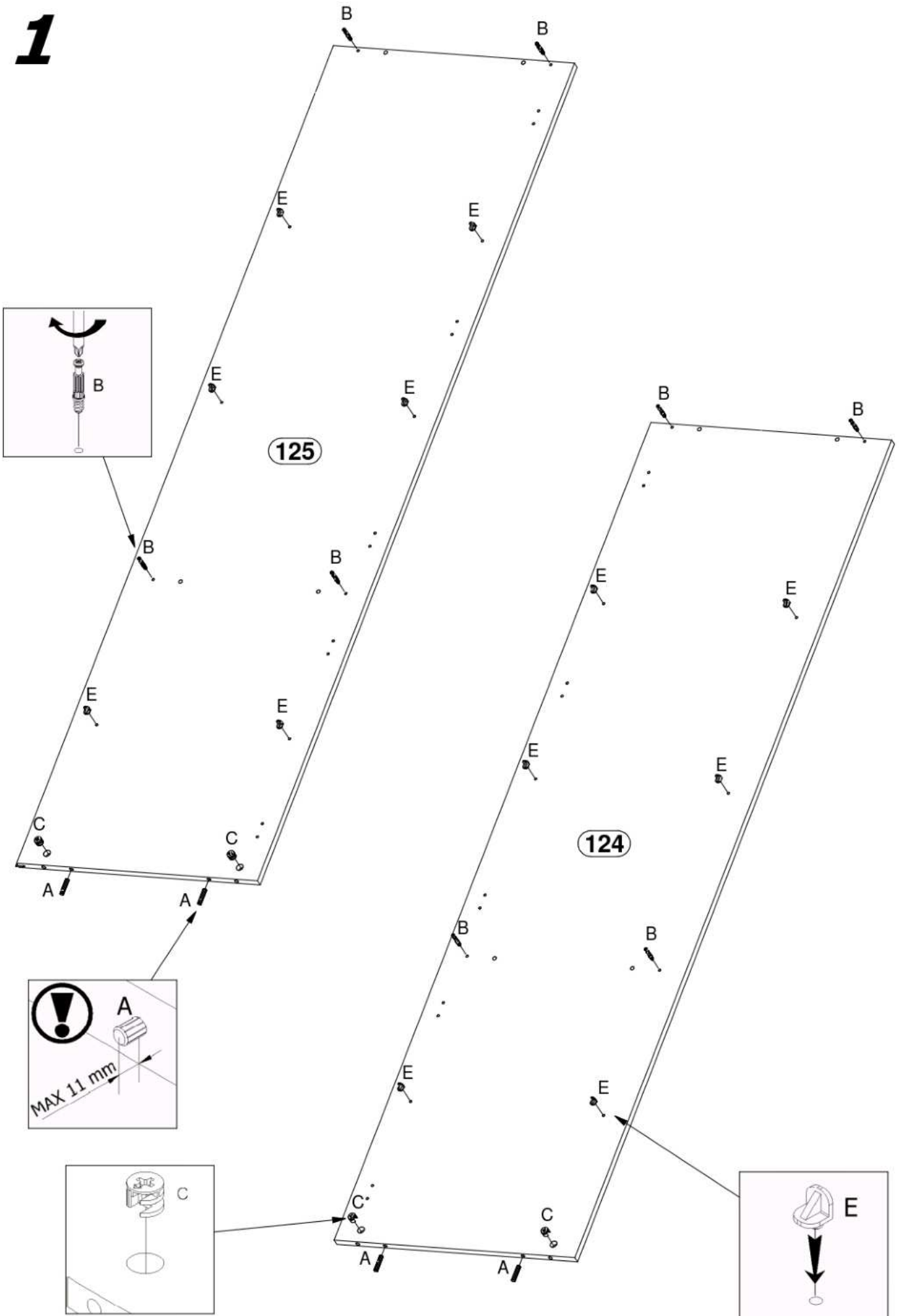

2

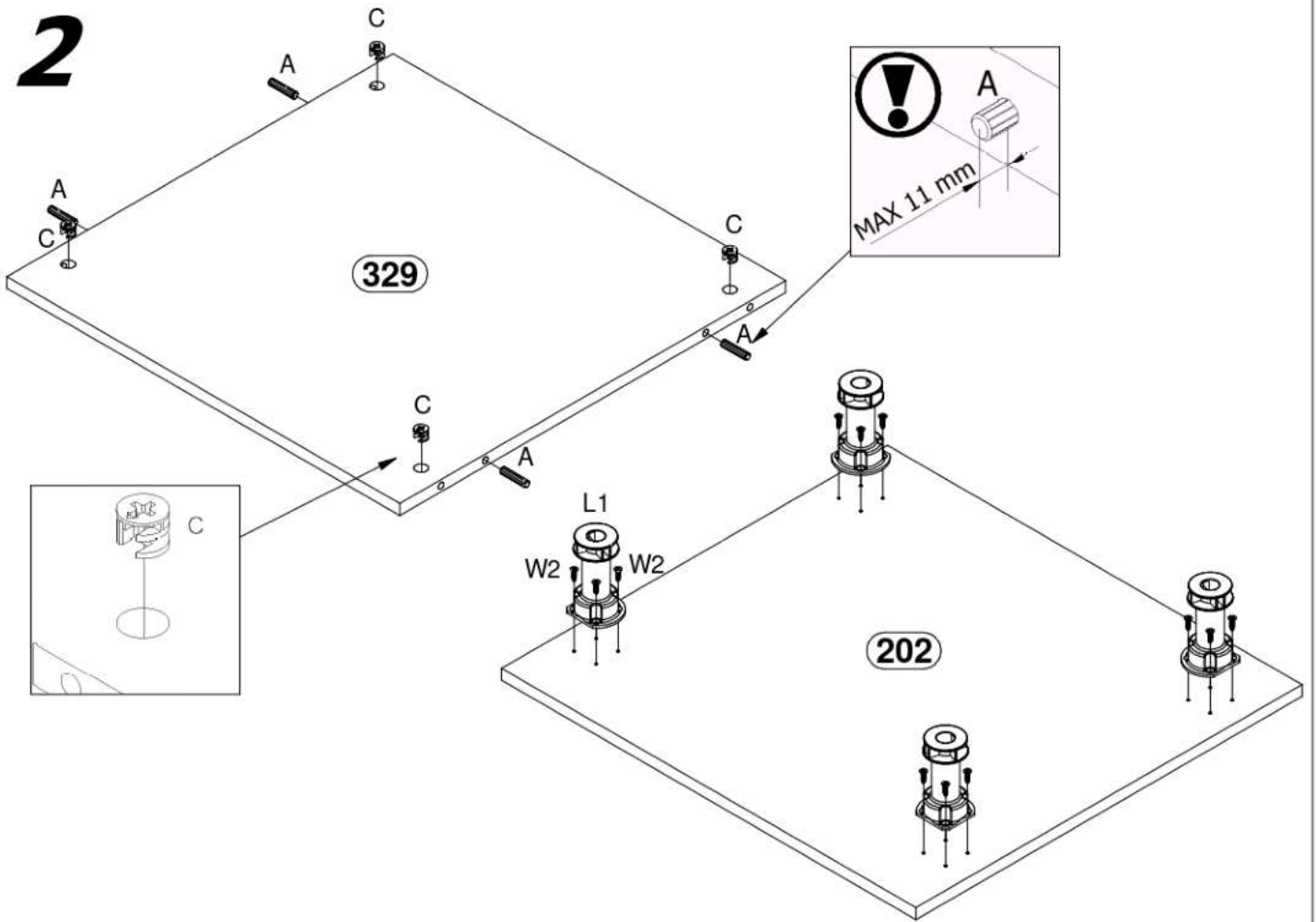

3

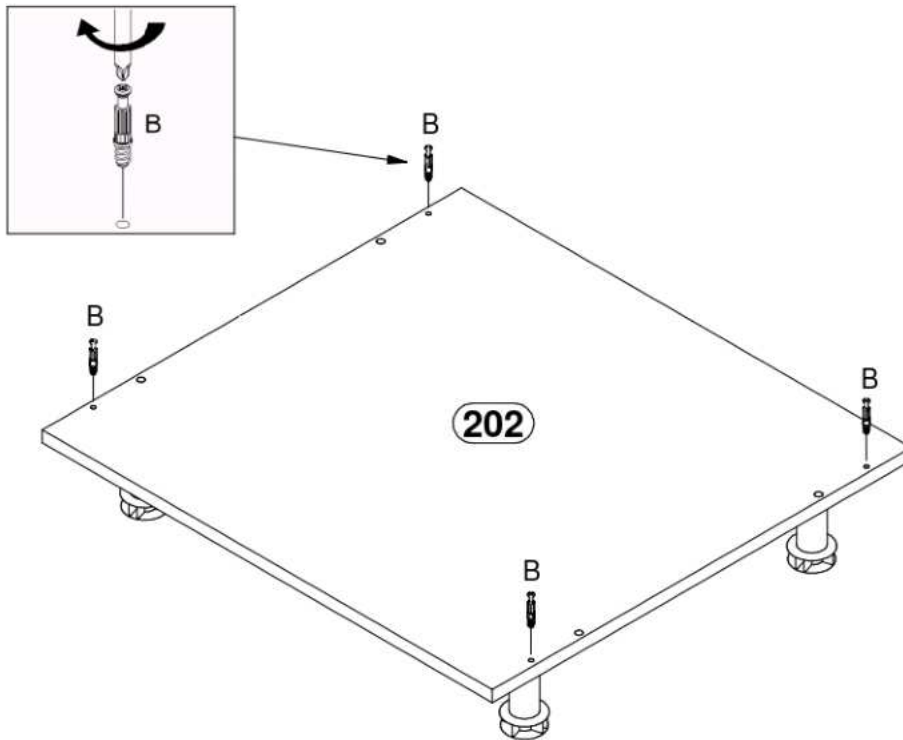

4

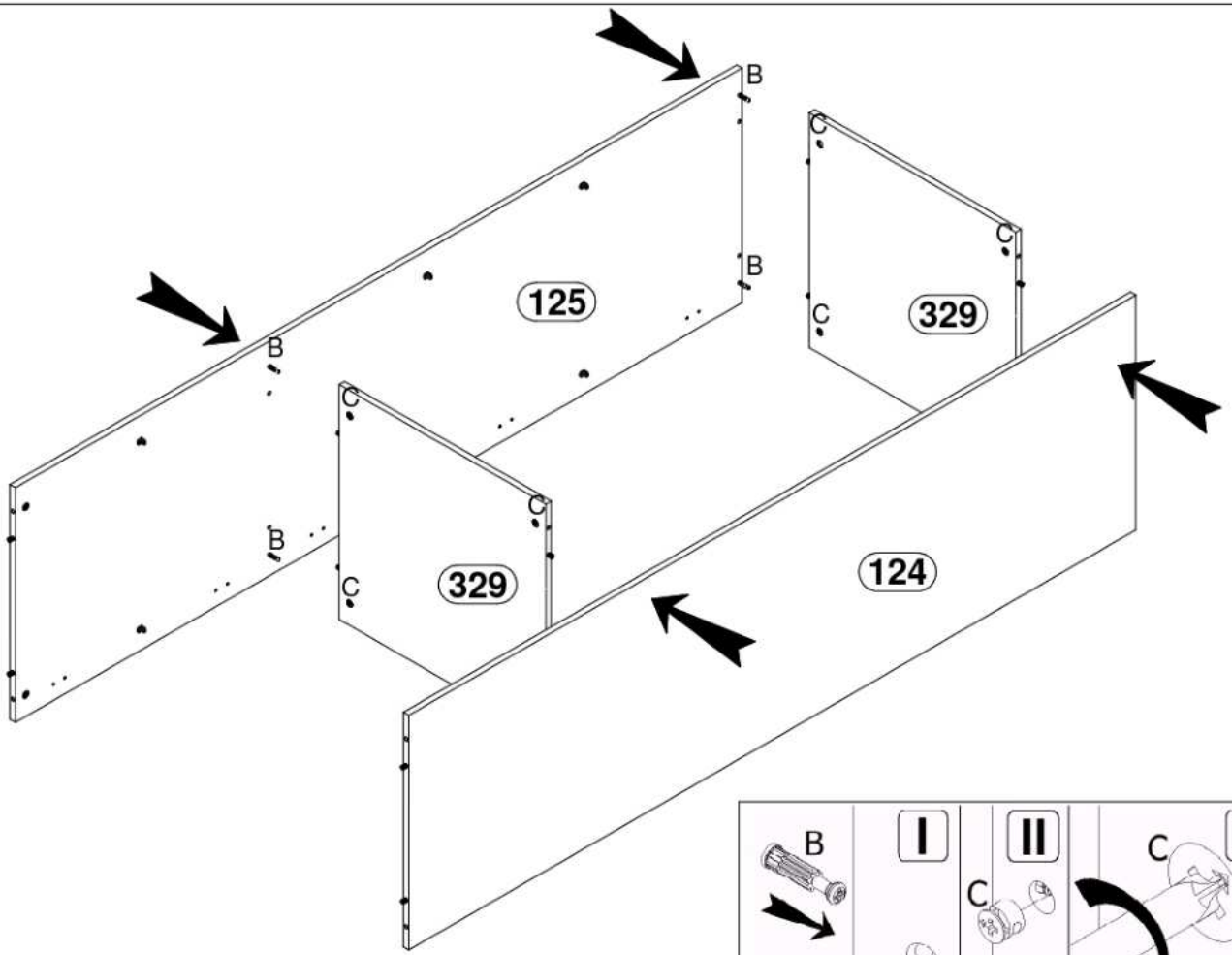

5

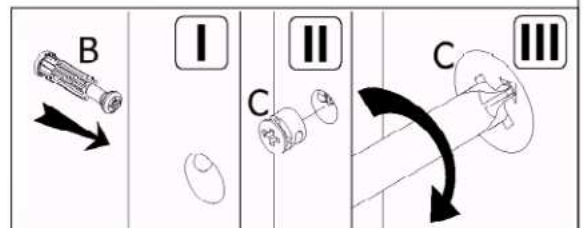
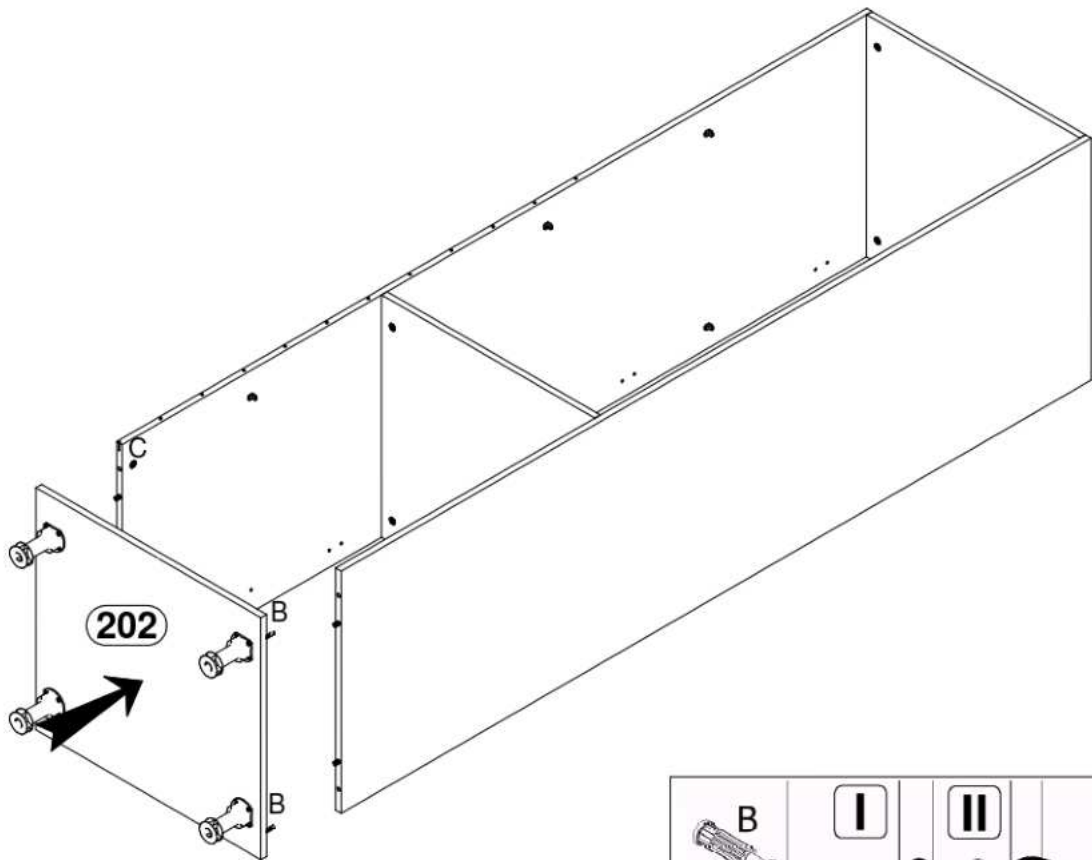

6

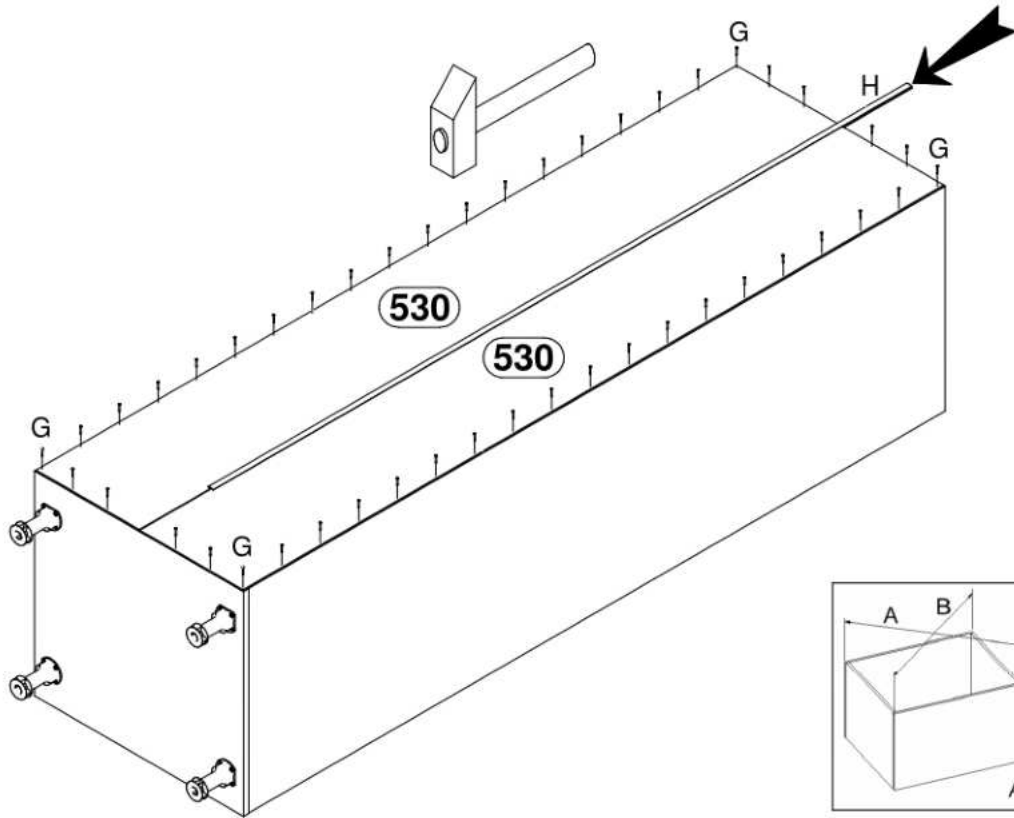

7

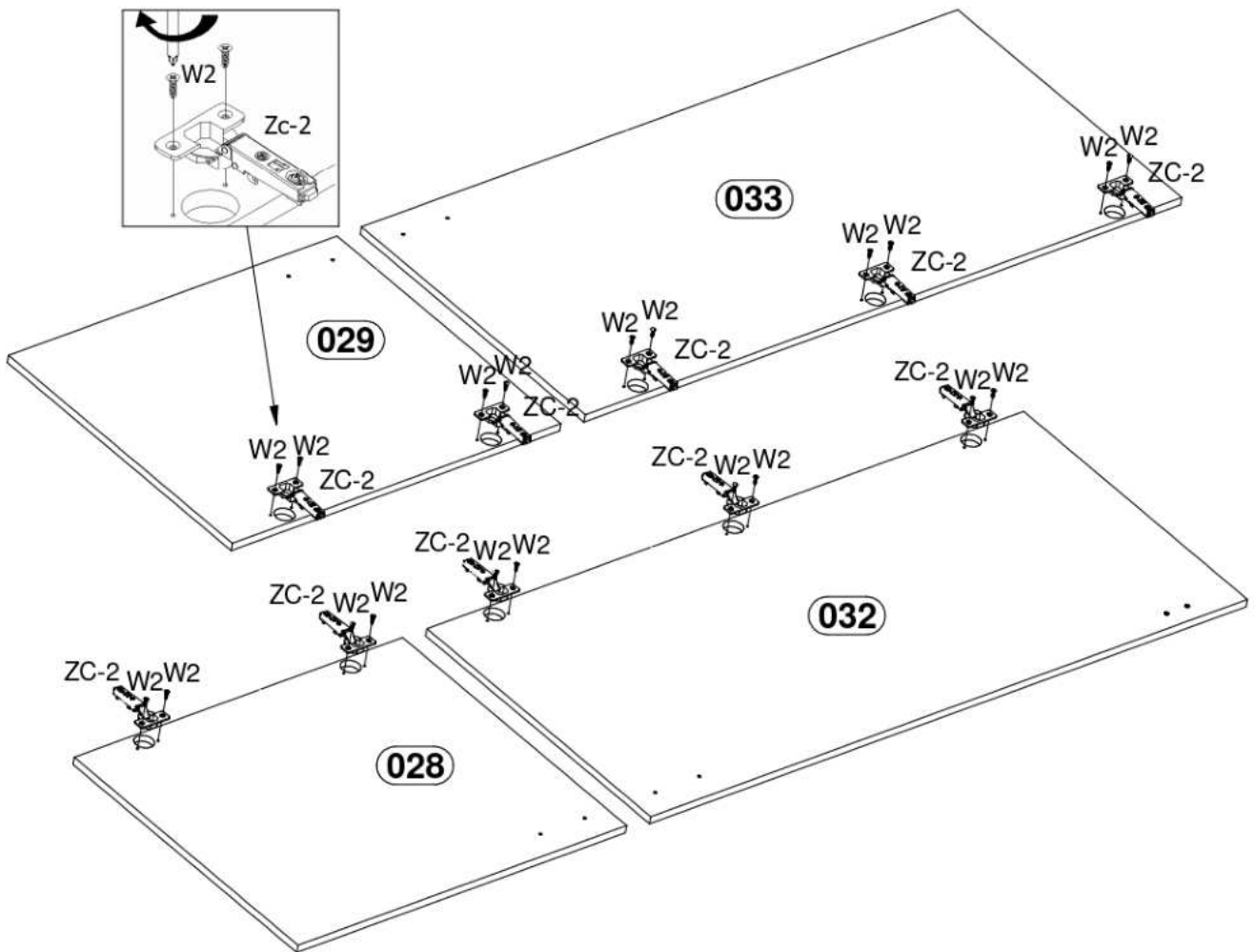

8

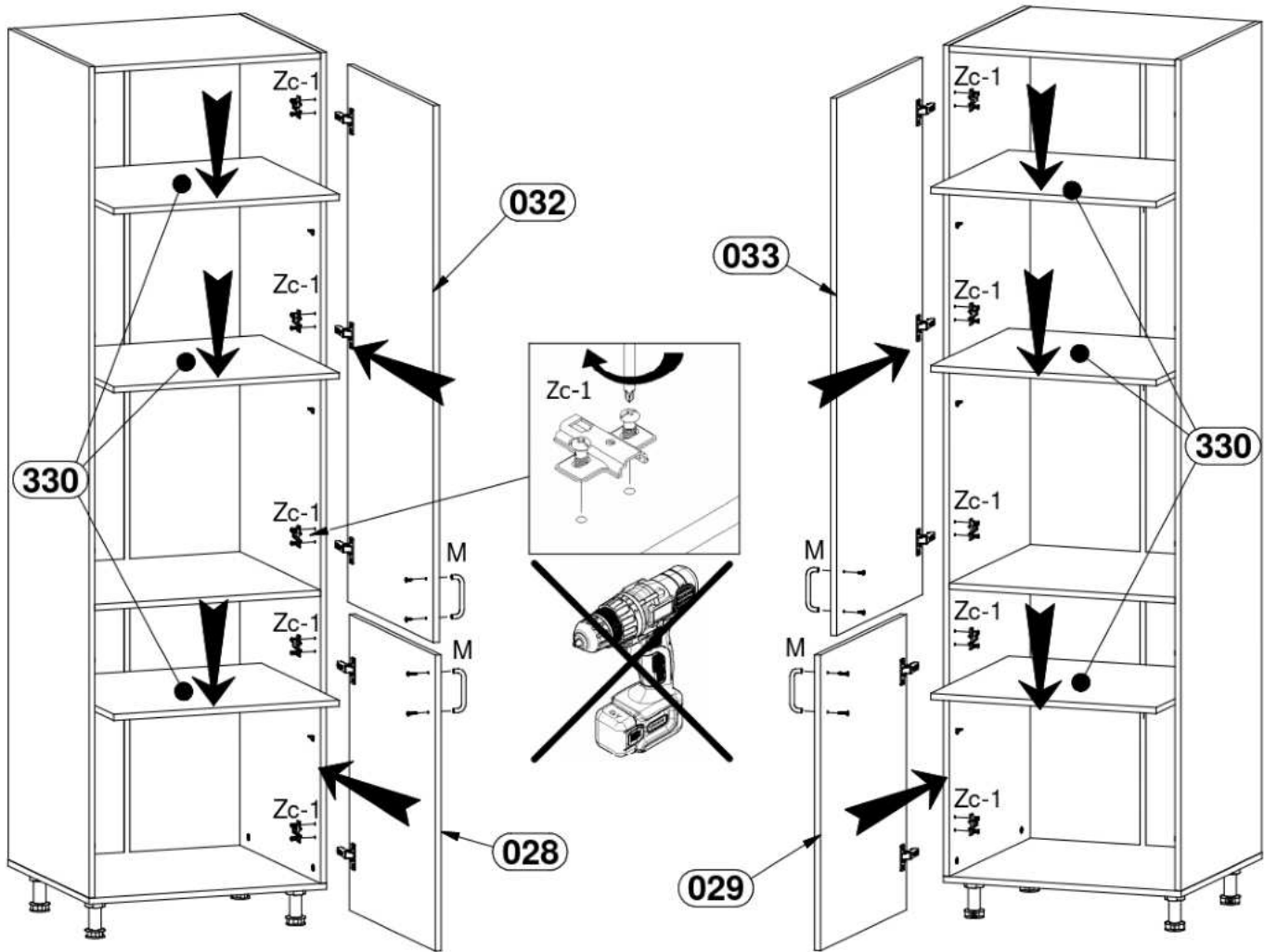

9

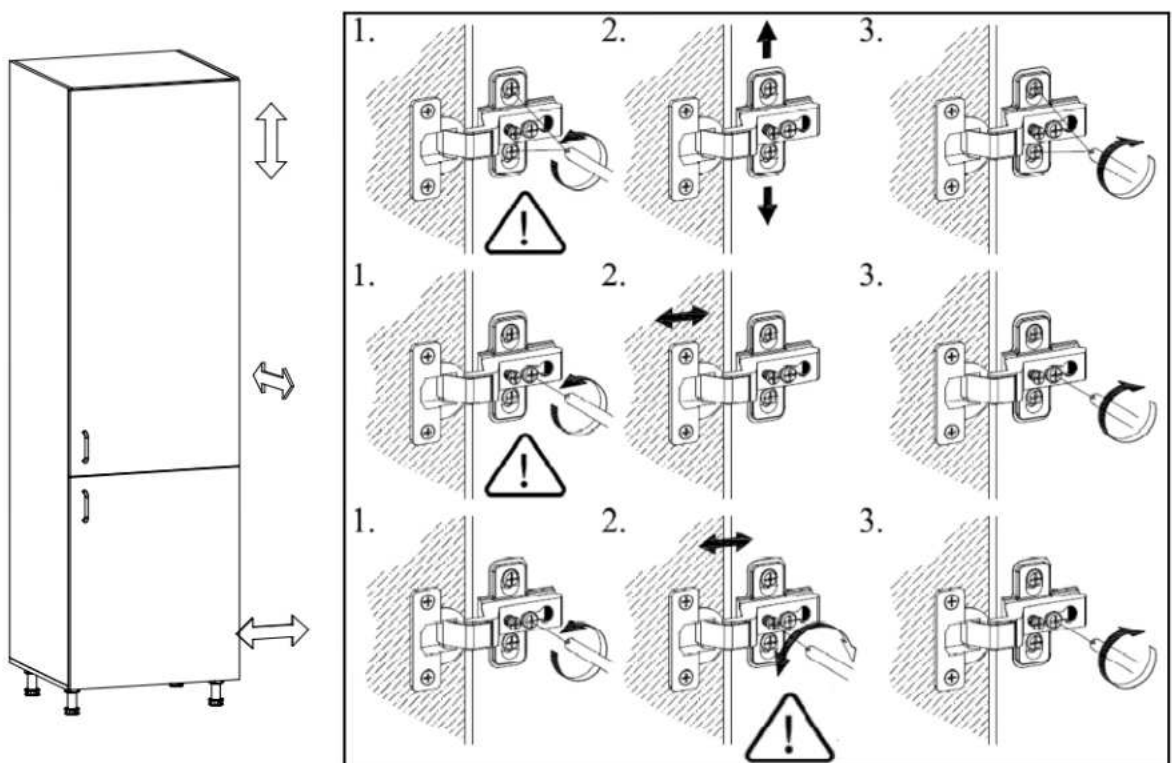

11

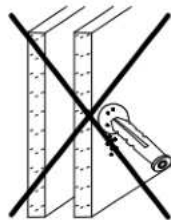
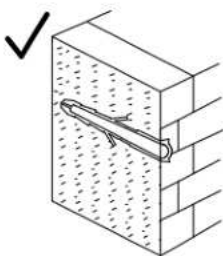
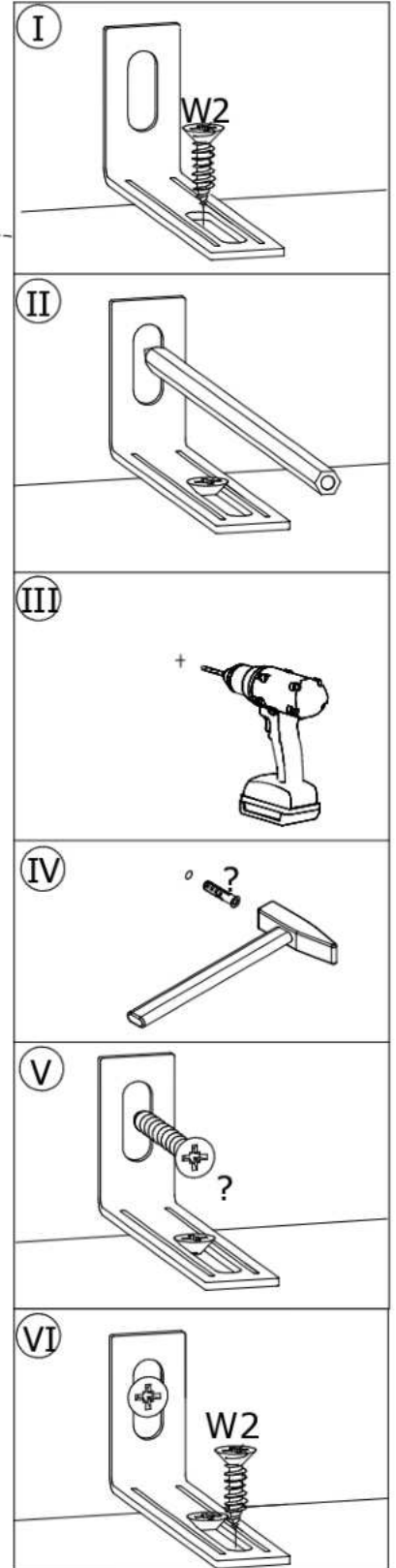
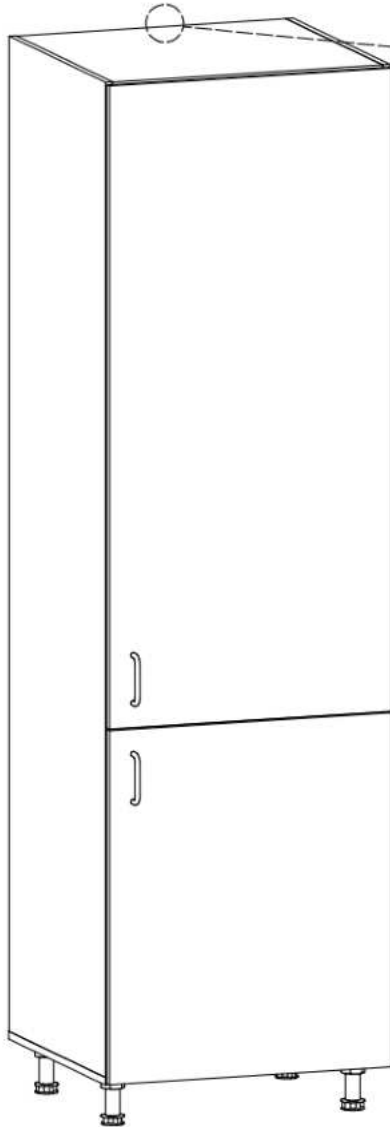
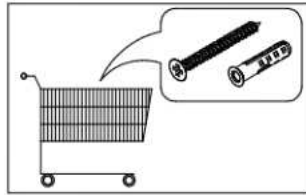
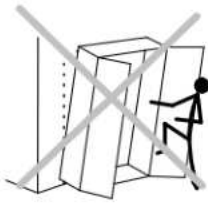
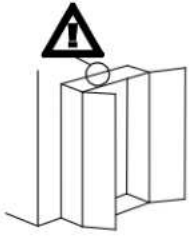

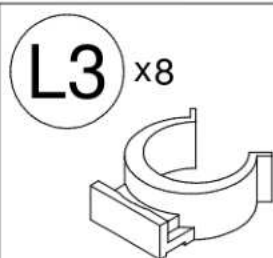
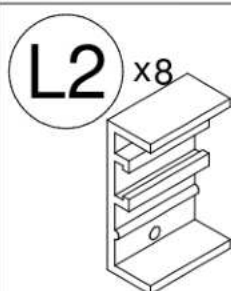
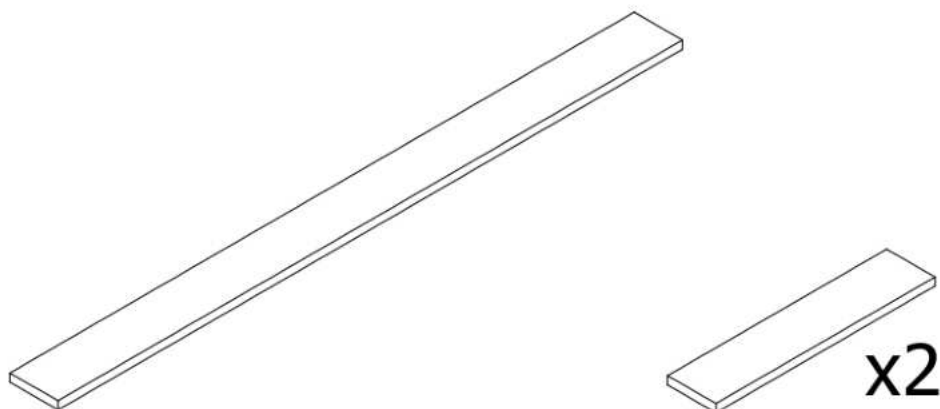
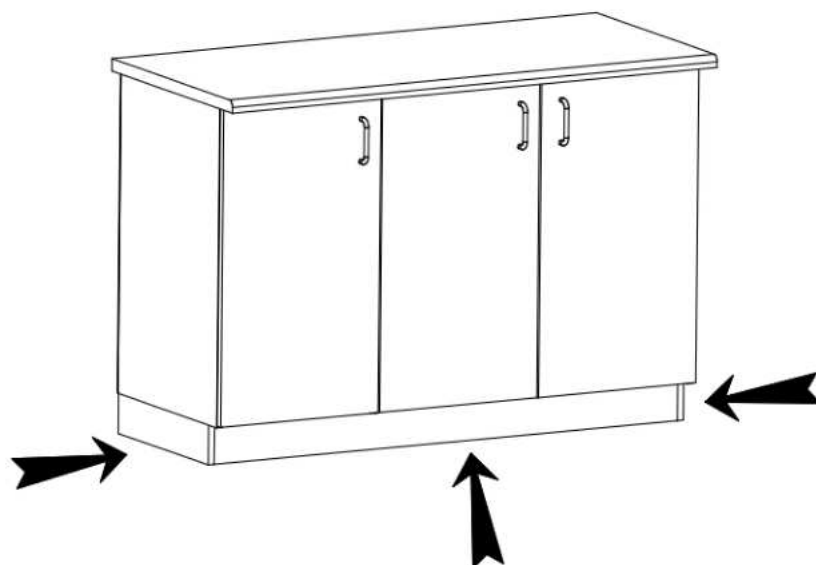

Ø3,5x16

10

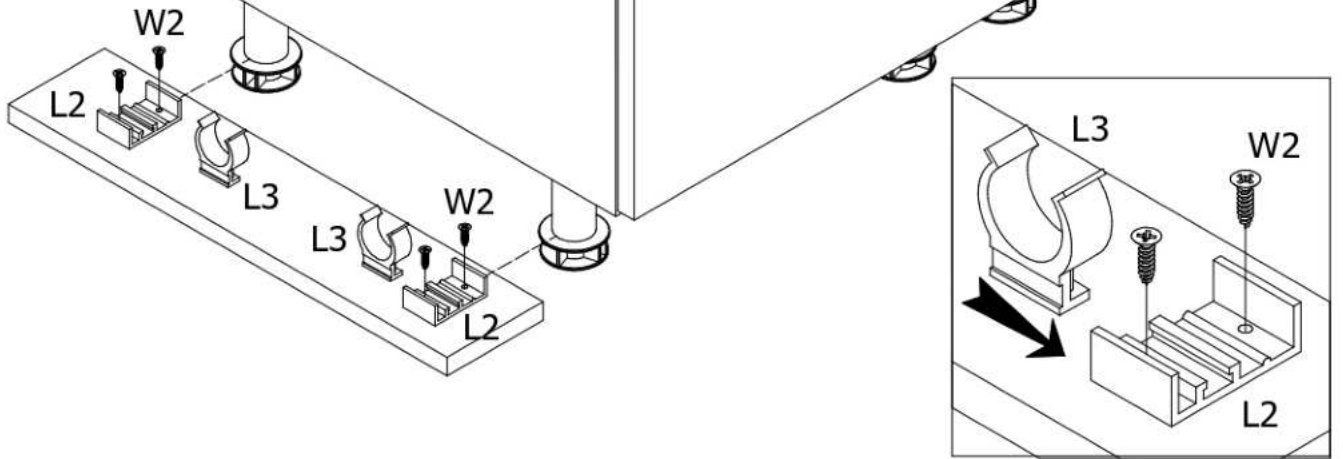

11

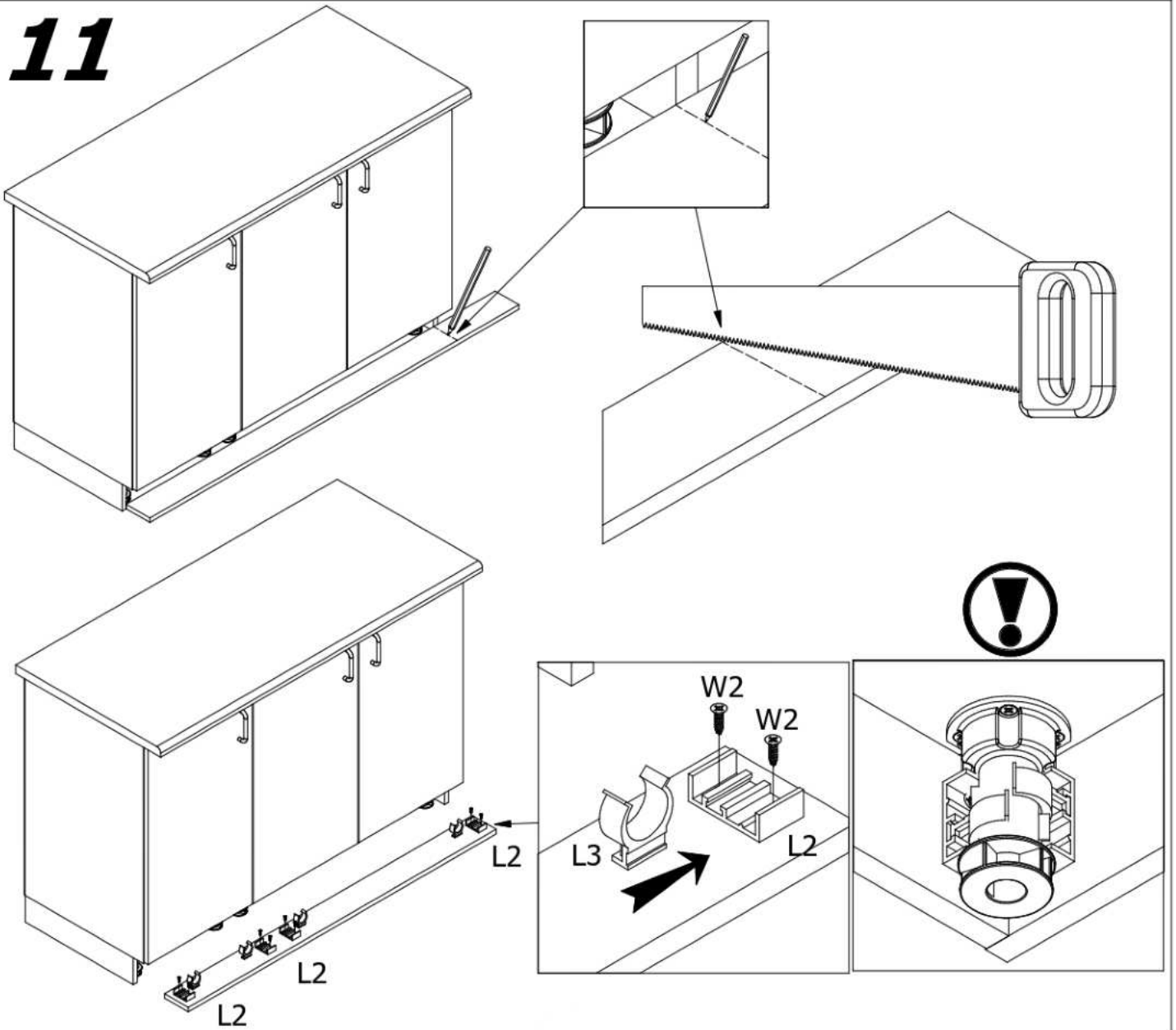

AURORA

D60S3

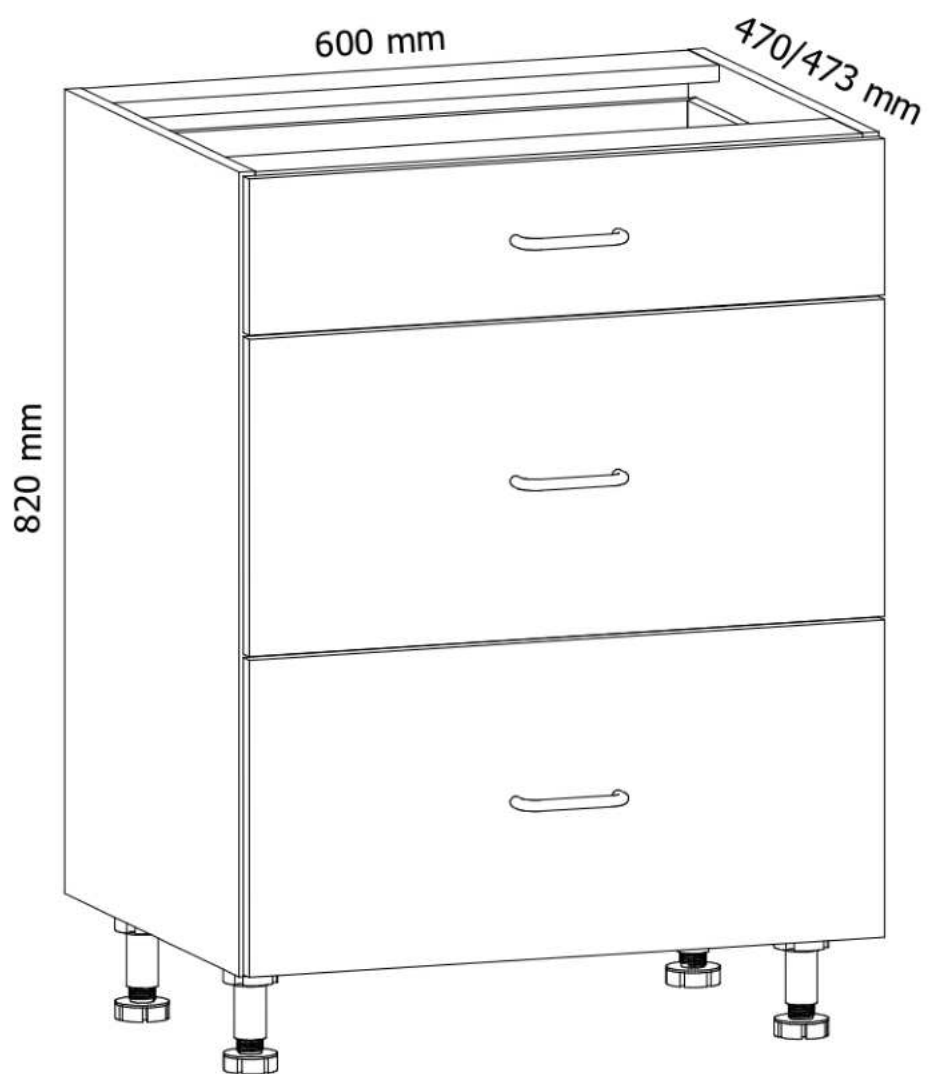

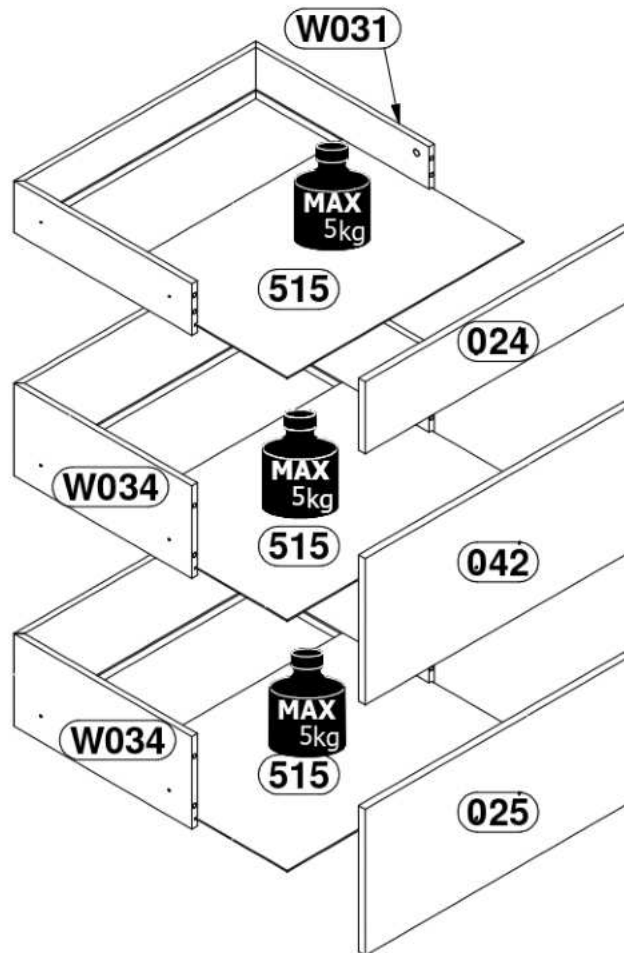
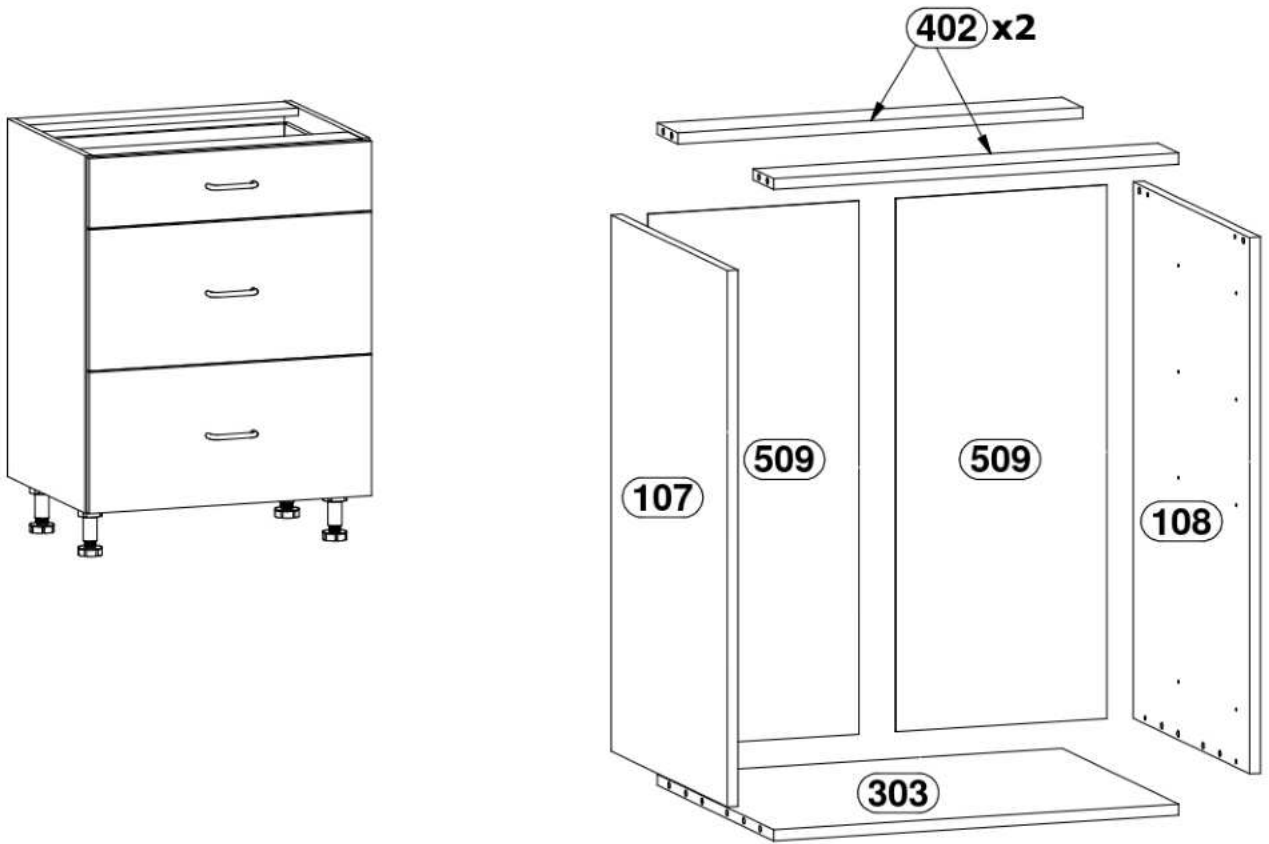

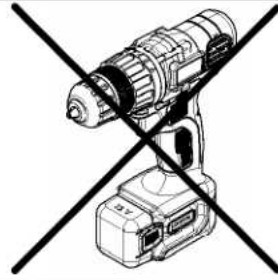
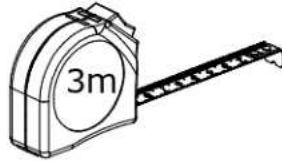
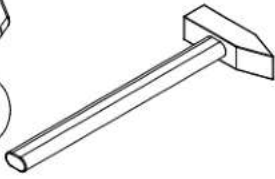
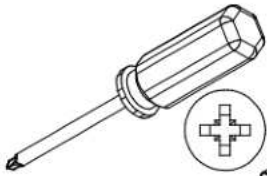

A1 x18

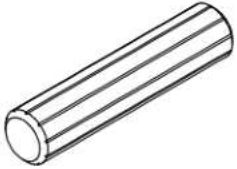

Ø8x35mm

B1 x14



Ø5x38mm

C1 x8

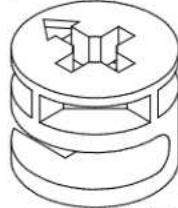

Ø15x12mm

C2 x6



Ø12x10mm

G1 x26

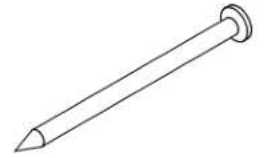

26mm

Hx1

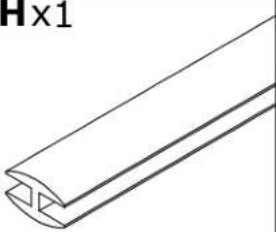

715mm

J x 6

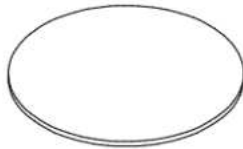

Ø21mm

L1 x 4



Ø50x95mm

Pc x6

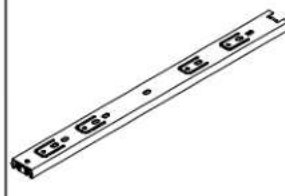

400mm

S3 x 3



400mm

Ux 3

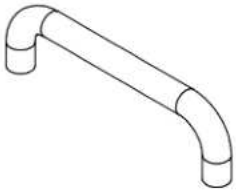

W1 x24

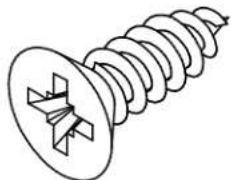

Ø3,5x13mm

W2x28

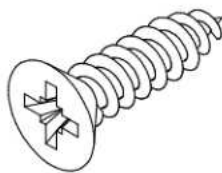

Ø3,5x16mm

X x6

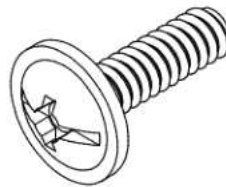

1

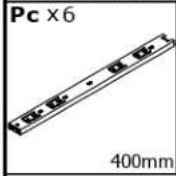
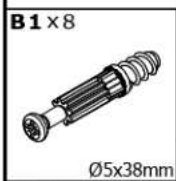

I

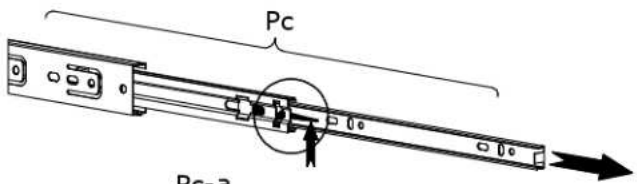

II

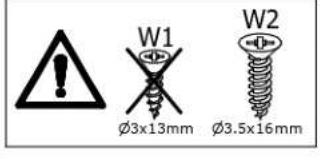
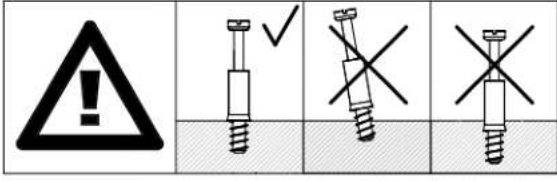
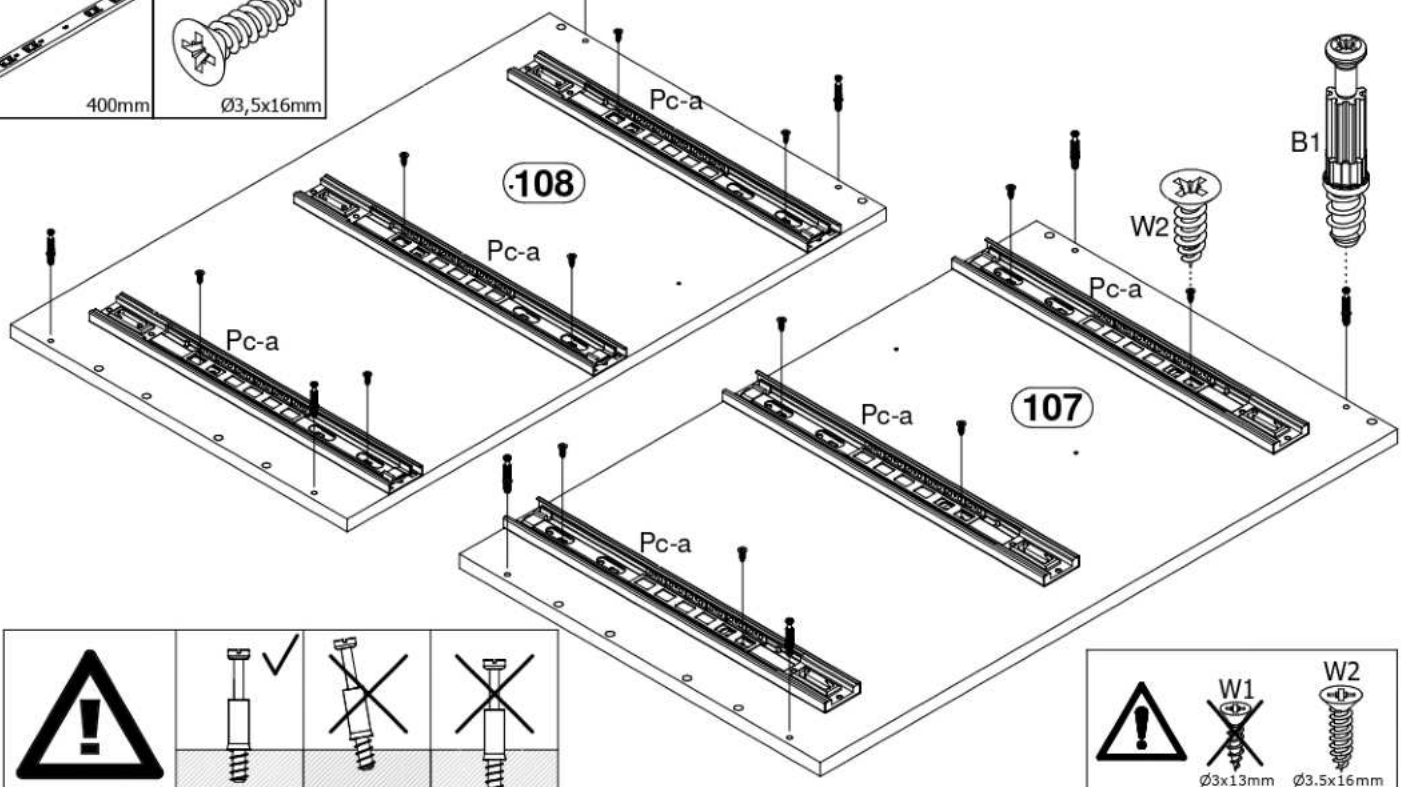
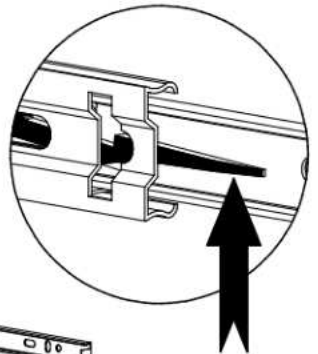
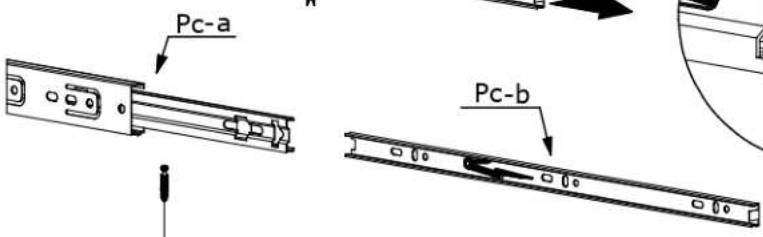

2

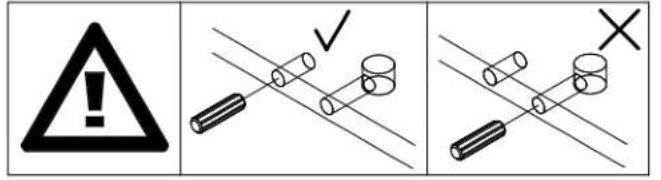
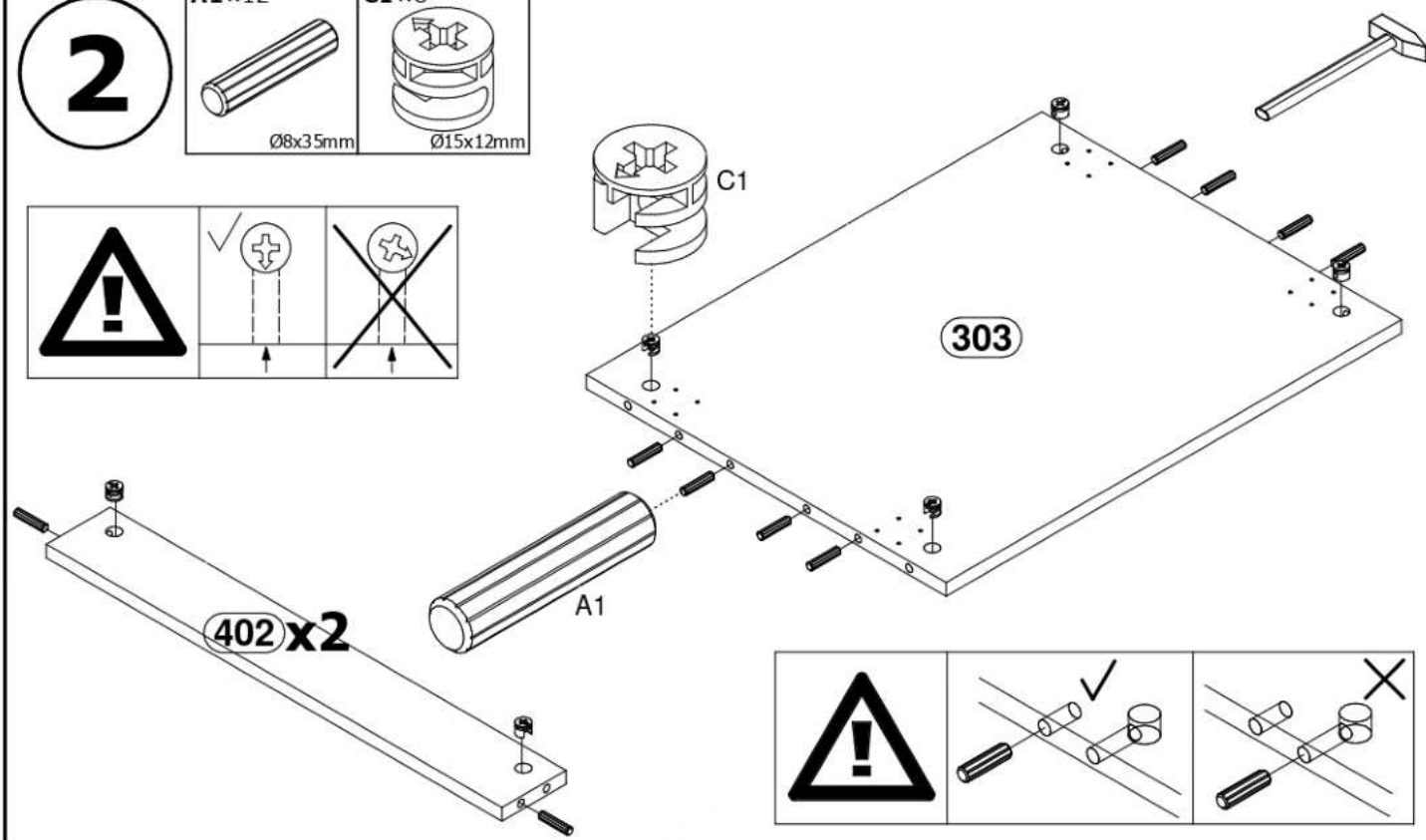
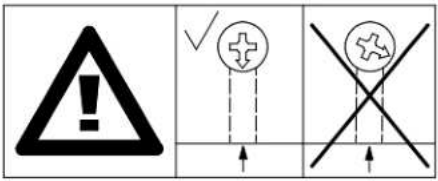
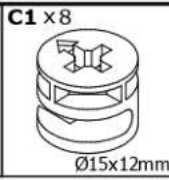

3

L1 x4



Ø50x95mm

W2 x16



Ø3,5x16mm

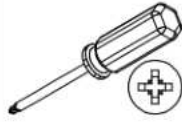

Ø3x13mm



Ø3,5x16mm

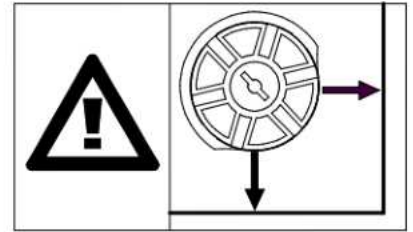
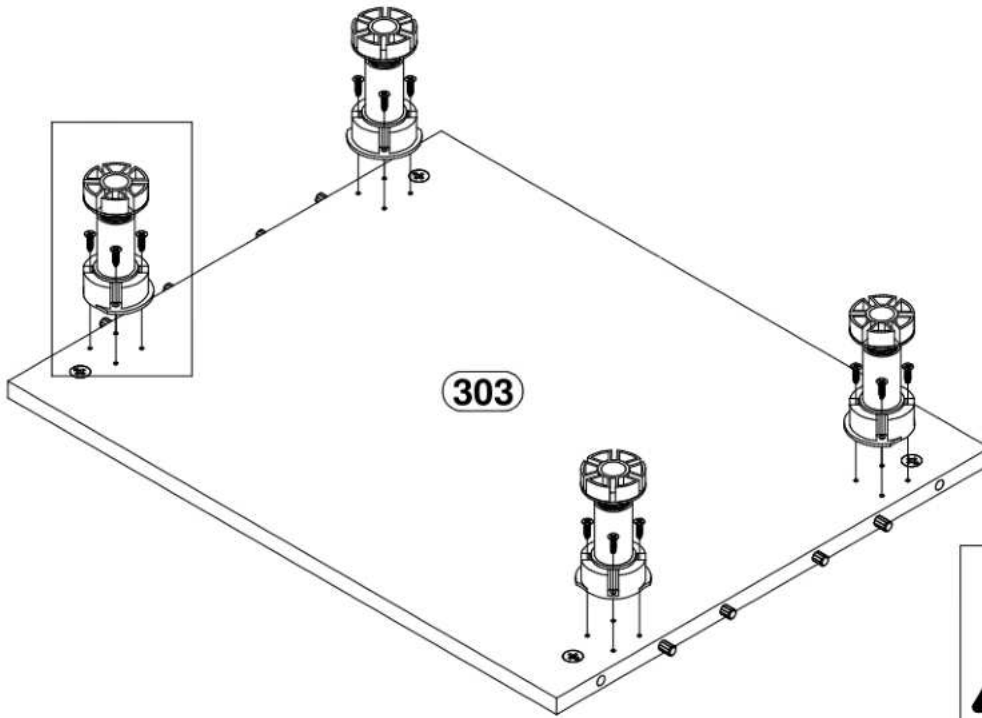
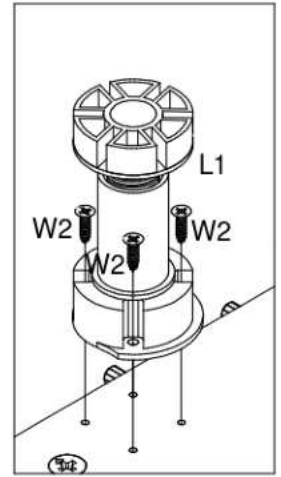

4

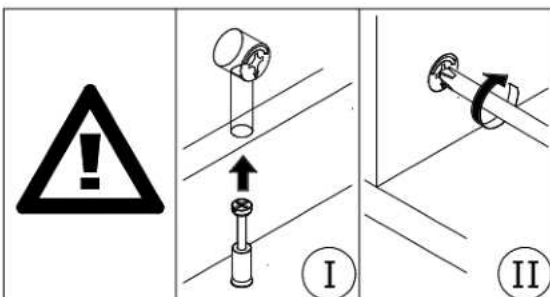
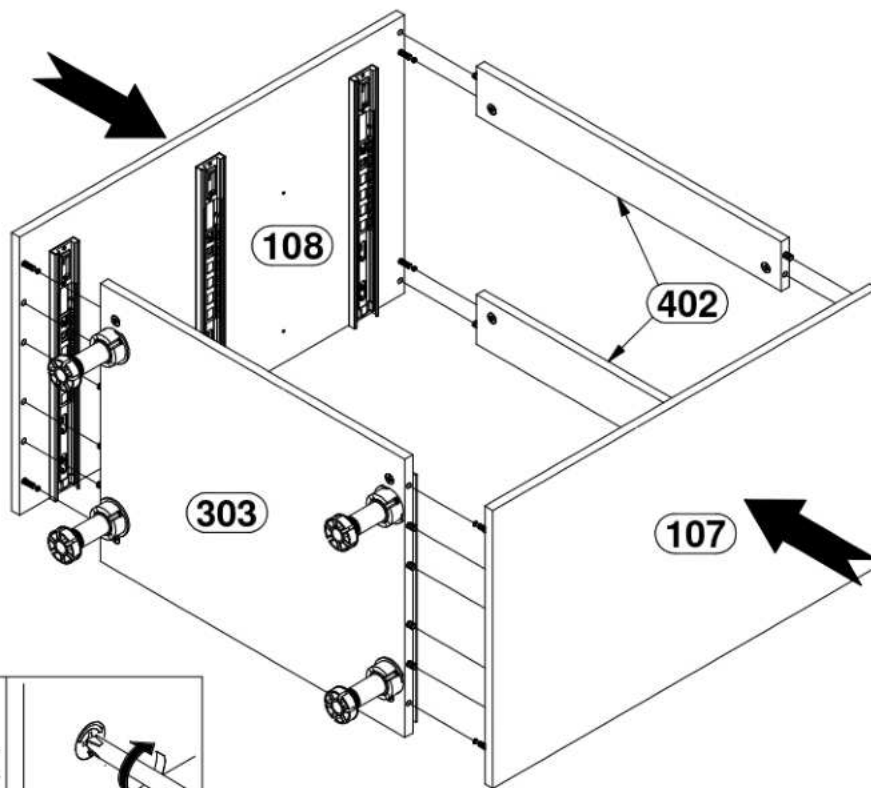
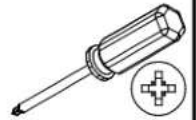

5

G1 x 26



26mm

H x 1



715mm

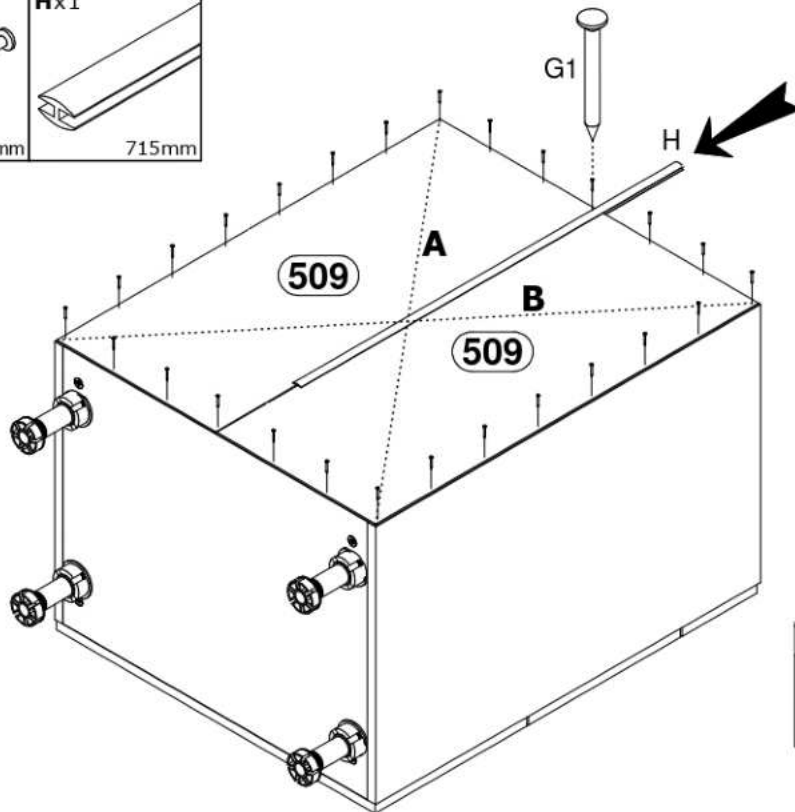

A=B ≡ 90°

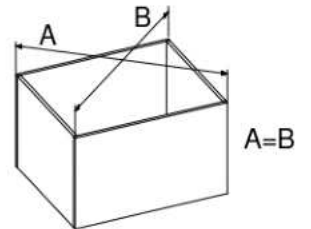

6

A1 x 6



Ø8x35mm

B1 x 6



Ø5x38mm

Pc-b x 6



400mm

W1 x 12



Ø3,5x13mm

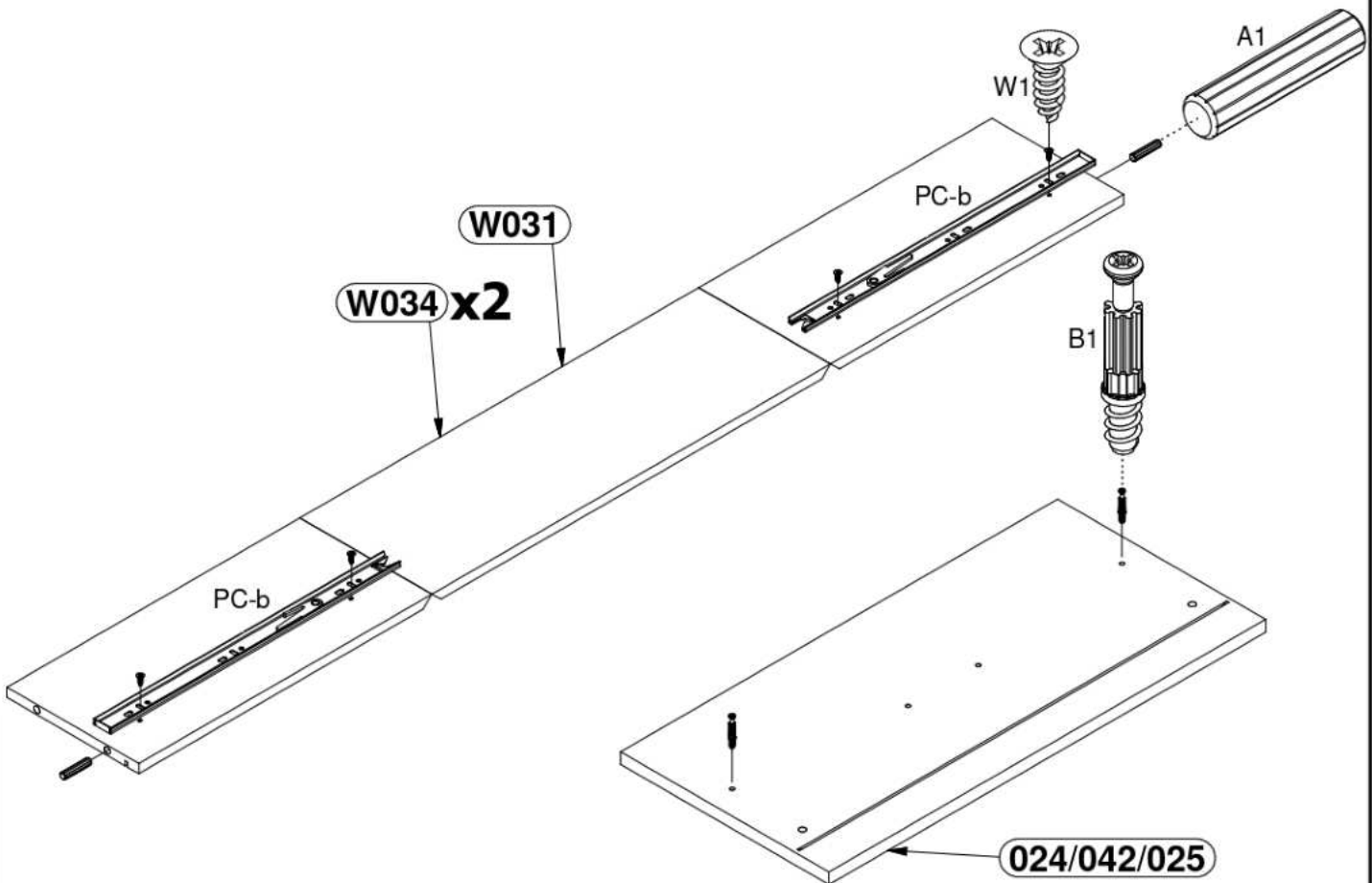
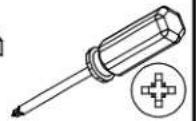

024/042/025

7

C2 x6



Ø12x10mm

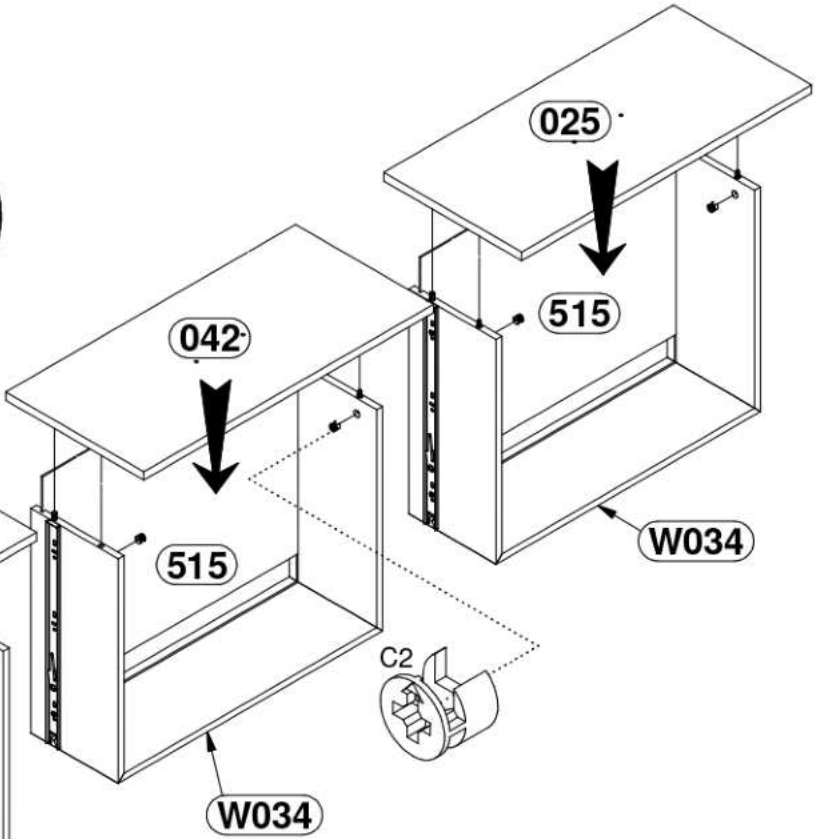
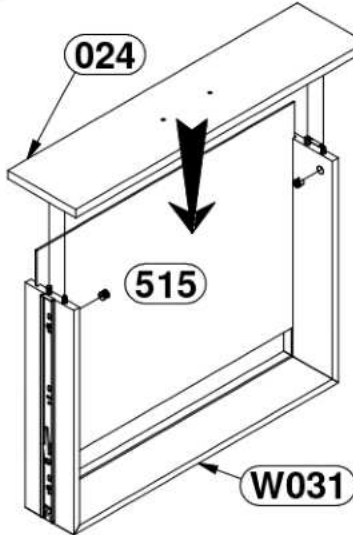
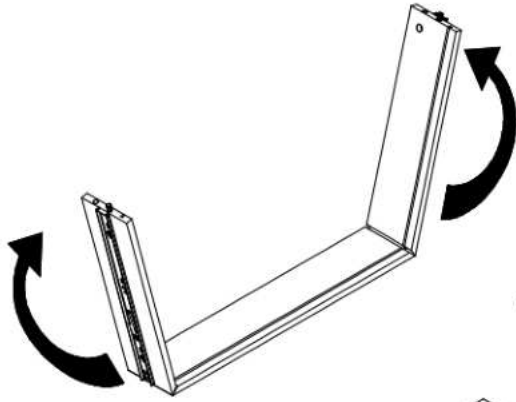
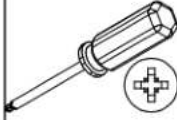

8

J x 6



Ø21mm

S3 x3



400mm

U x3



W1 x6



Ø3,5x13mm

X x6

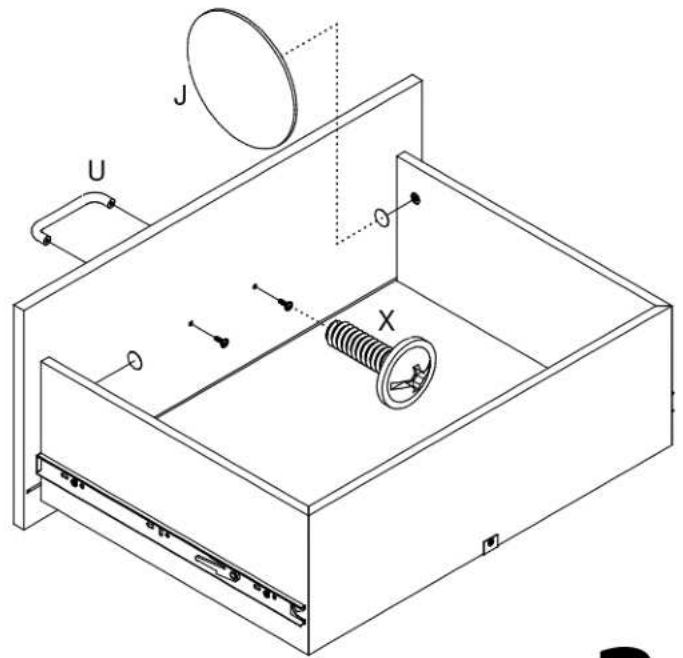
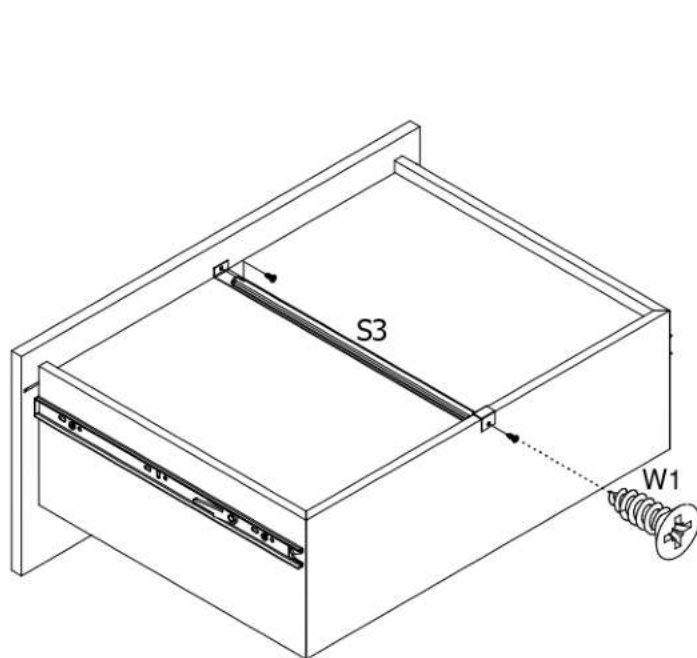
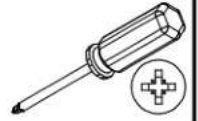

x3

9

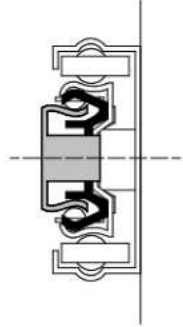
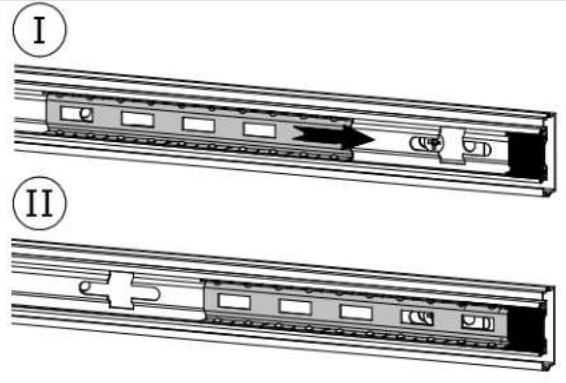
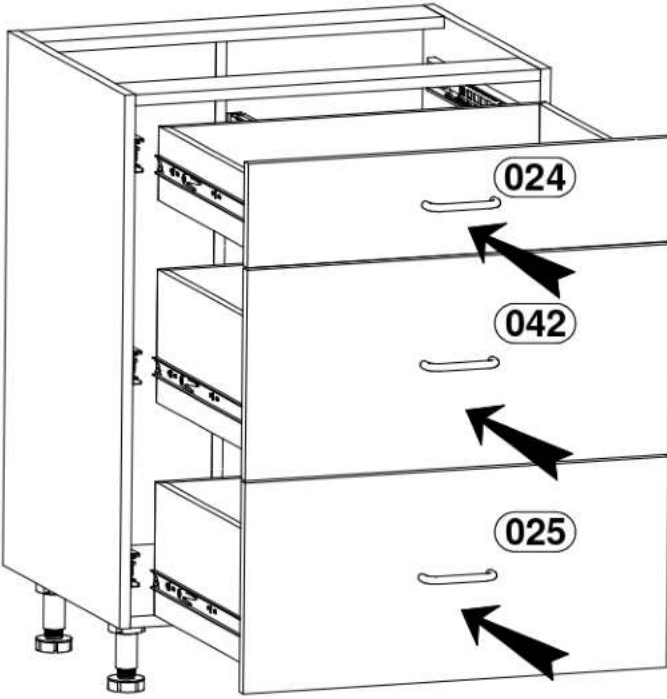

10

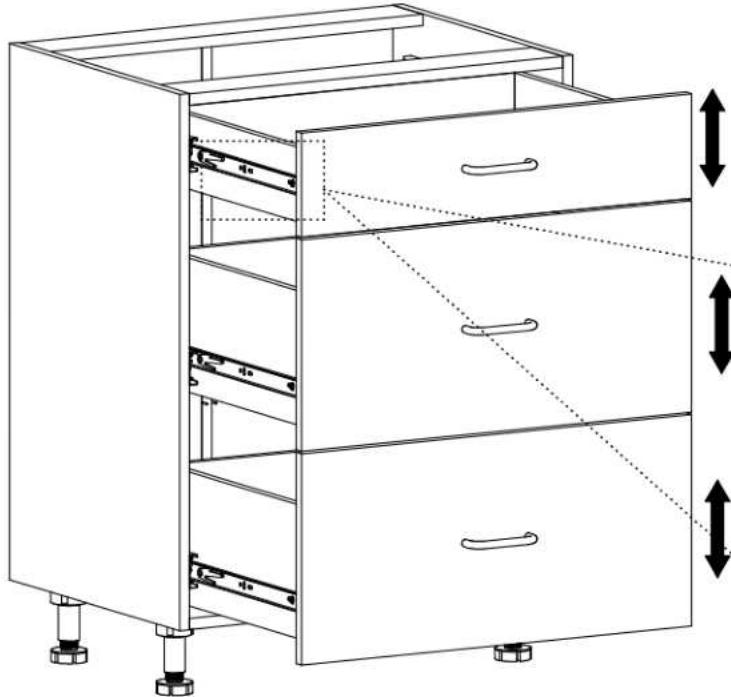
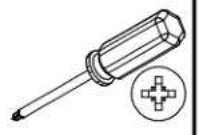

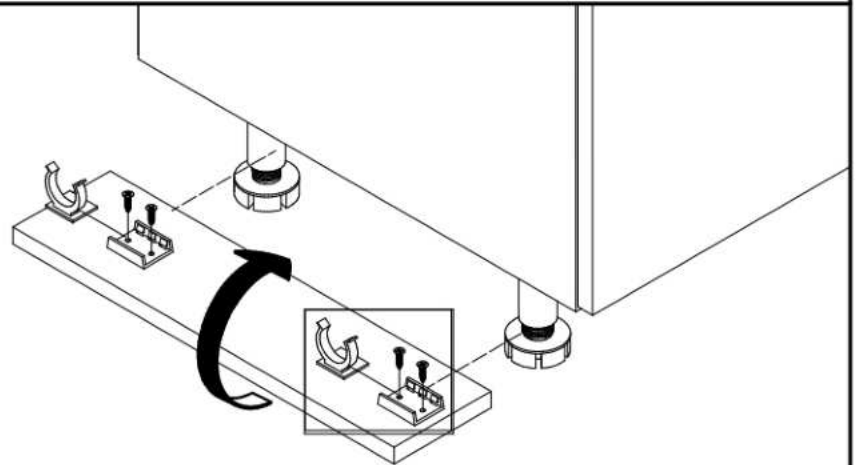
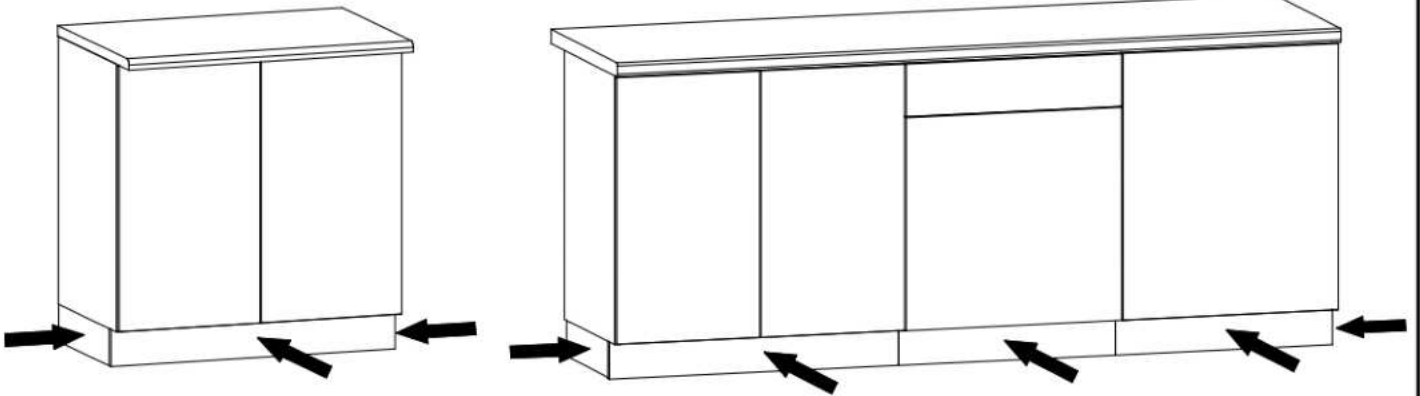
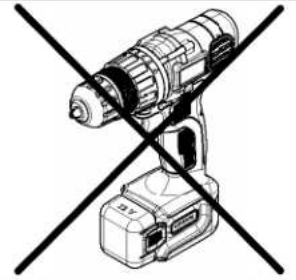
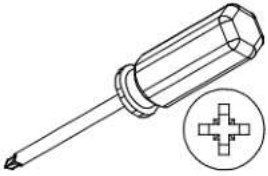

L6-a x4

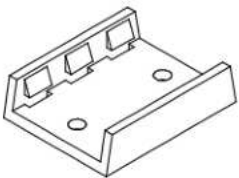

38x30x10mm

L6-b x4

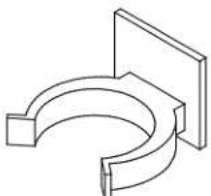

35x32x25mm

W2 x8

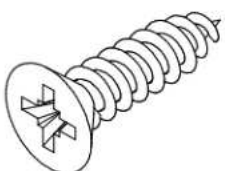

Ø3,5x16mm

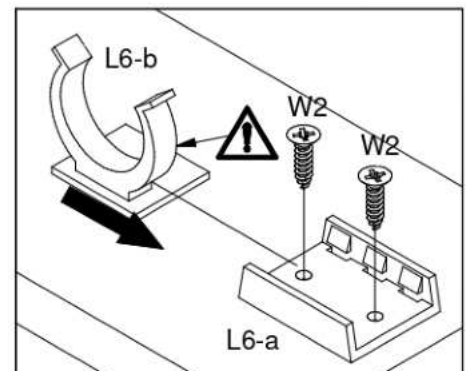

C2

L6-a x 2

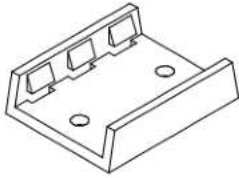

38x30x10mm

L6-b x 2

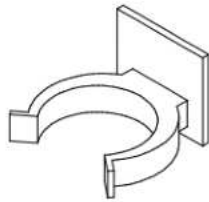

35x32x25mm

W2 x 4

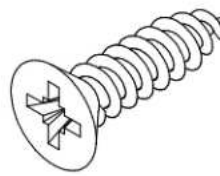

Ø3,5x16mm

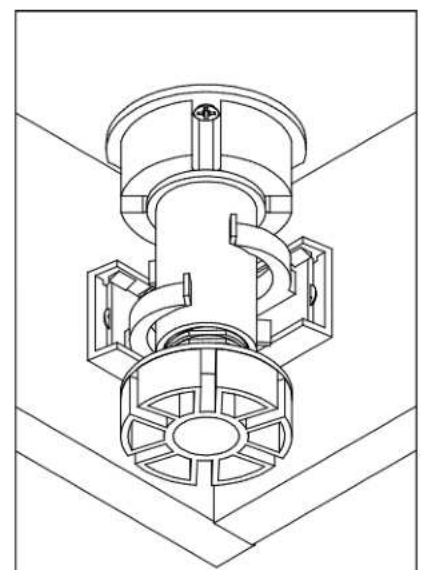
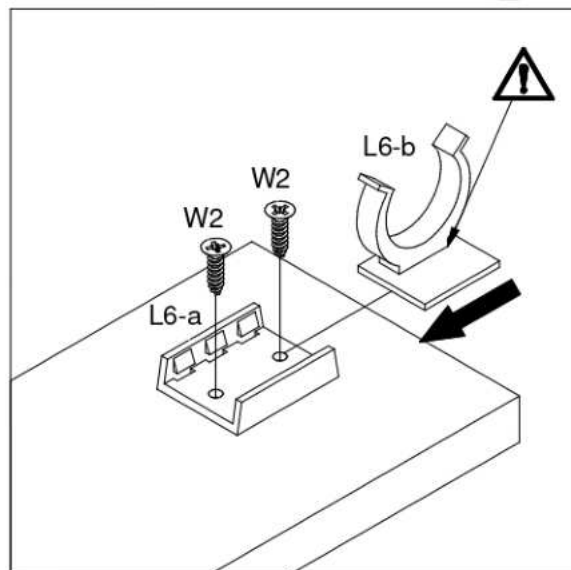
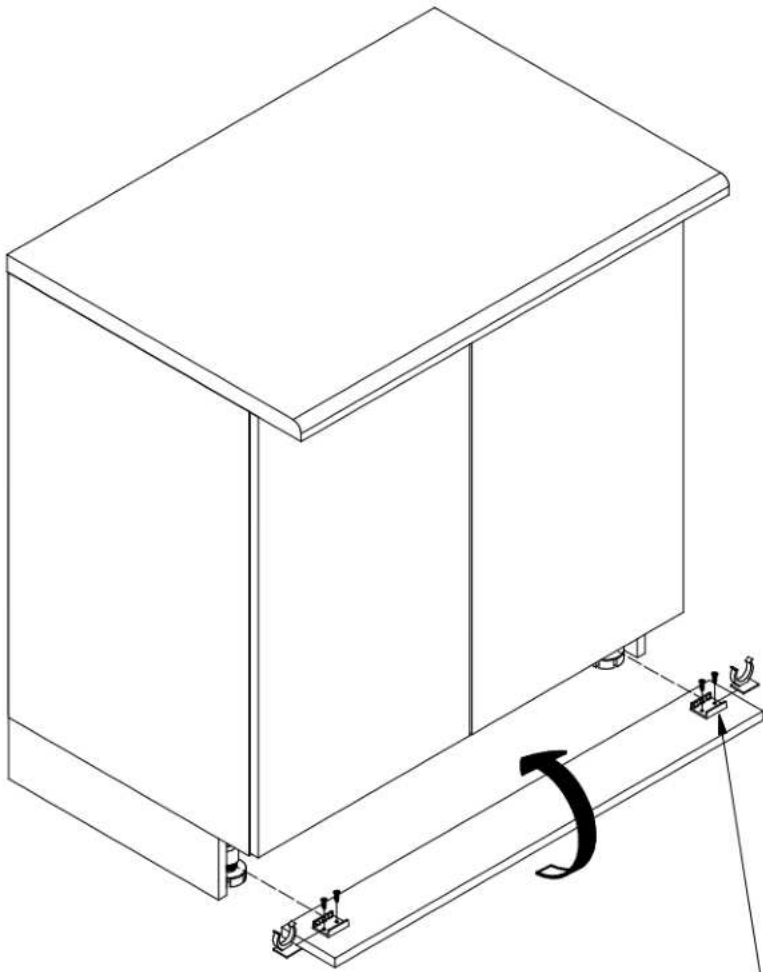
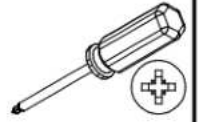





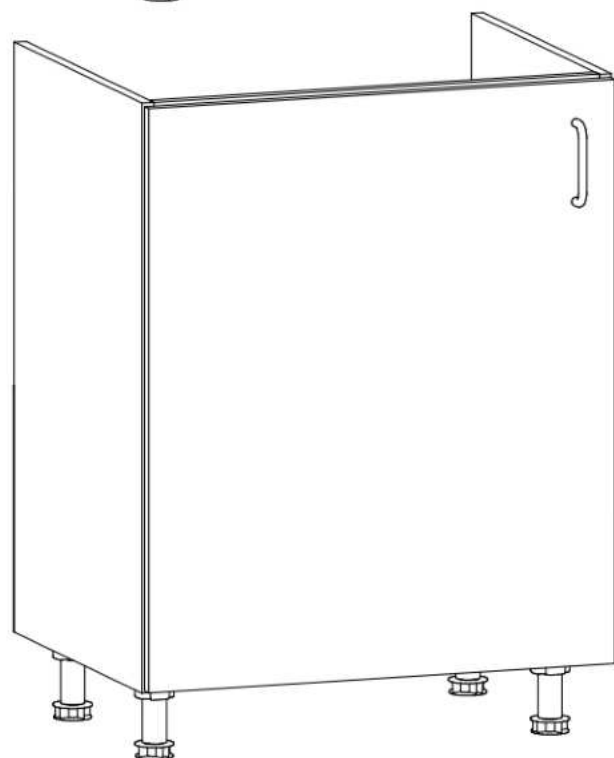
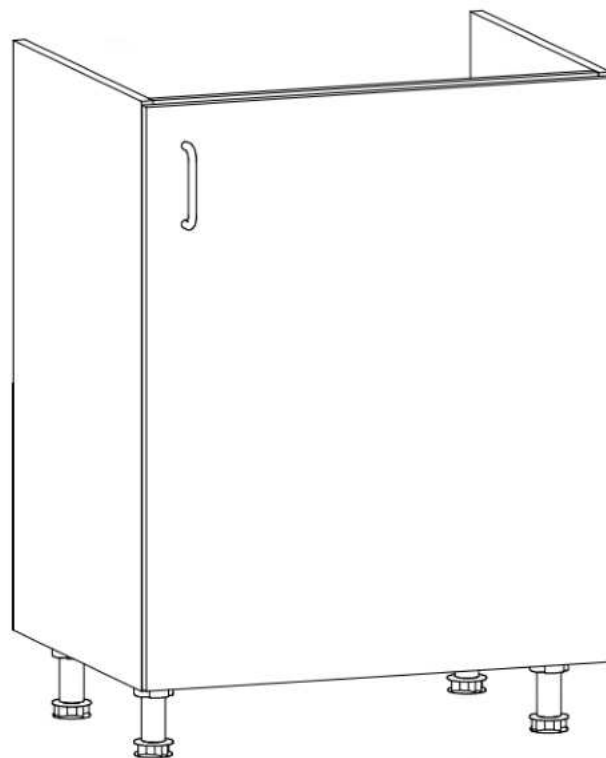
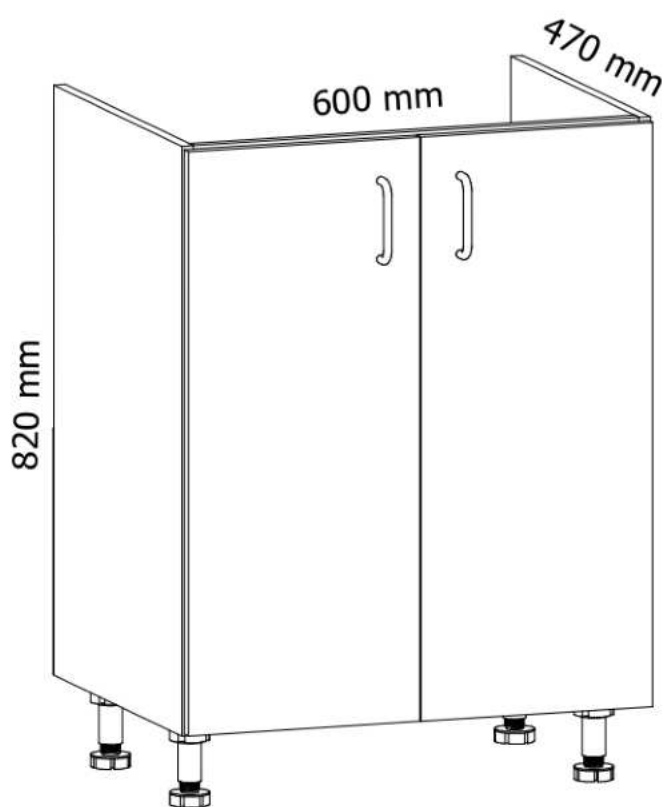

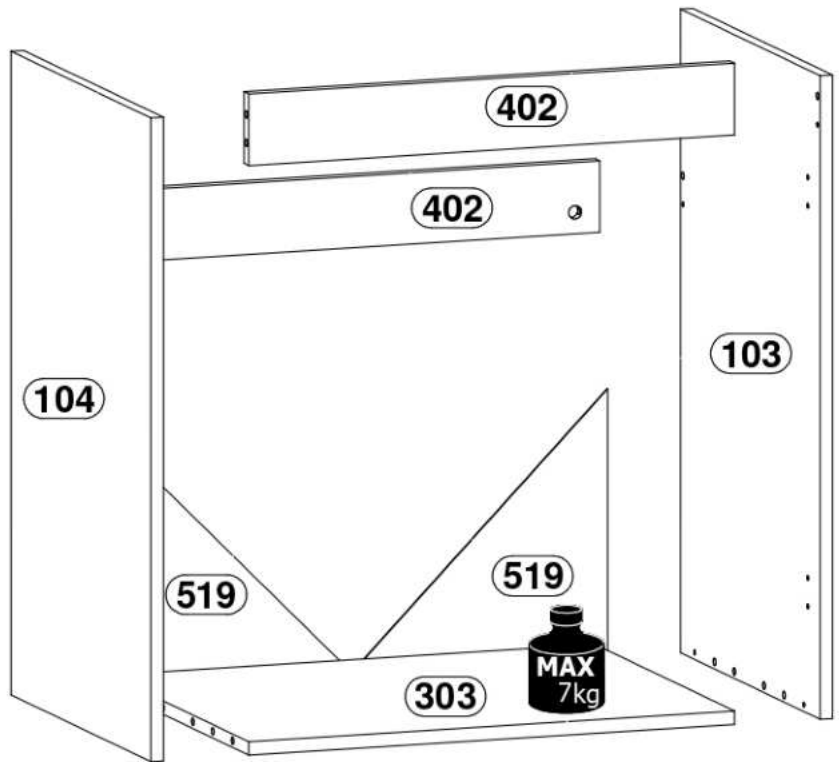
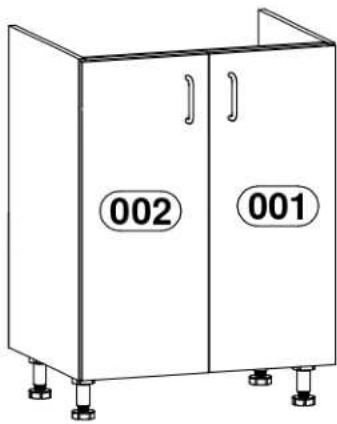
AURORA

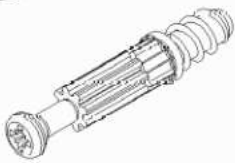
D60Z/D60Z-P/D60Z-L

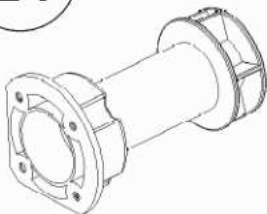

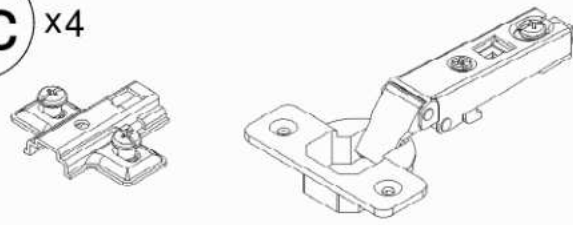

<p>A x12</p>  <p>Ø8x35mm</p>	<p>B x8</p> 	<p>C x8</p>  <p>Ø15x12mm</p>	<p>G x15</p> 
<p>L1 x4</p> 	<p>M x2</p> 	<p>W2 x24</p>  <p>Ø3,5x16mm</p>	<p>Y x8</p>  <p>Ø18 mm</p>
<p>Zc x4</p>  <p>Zc-1 Zc-2</p>			

1

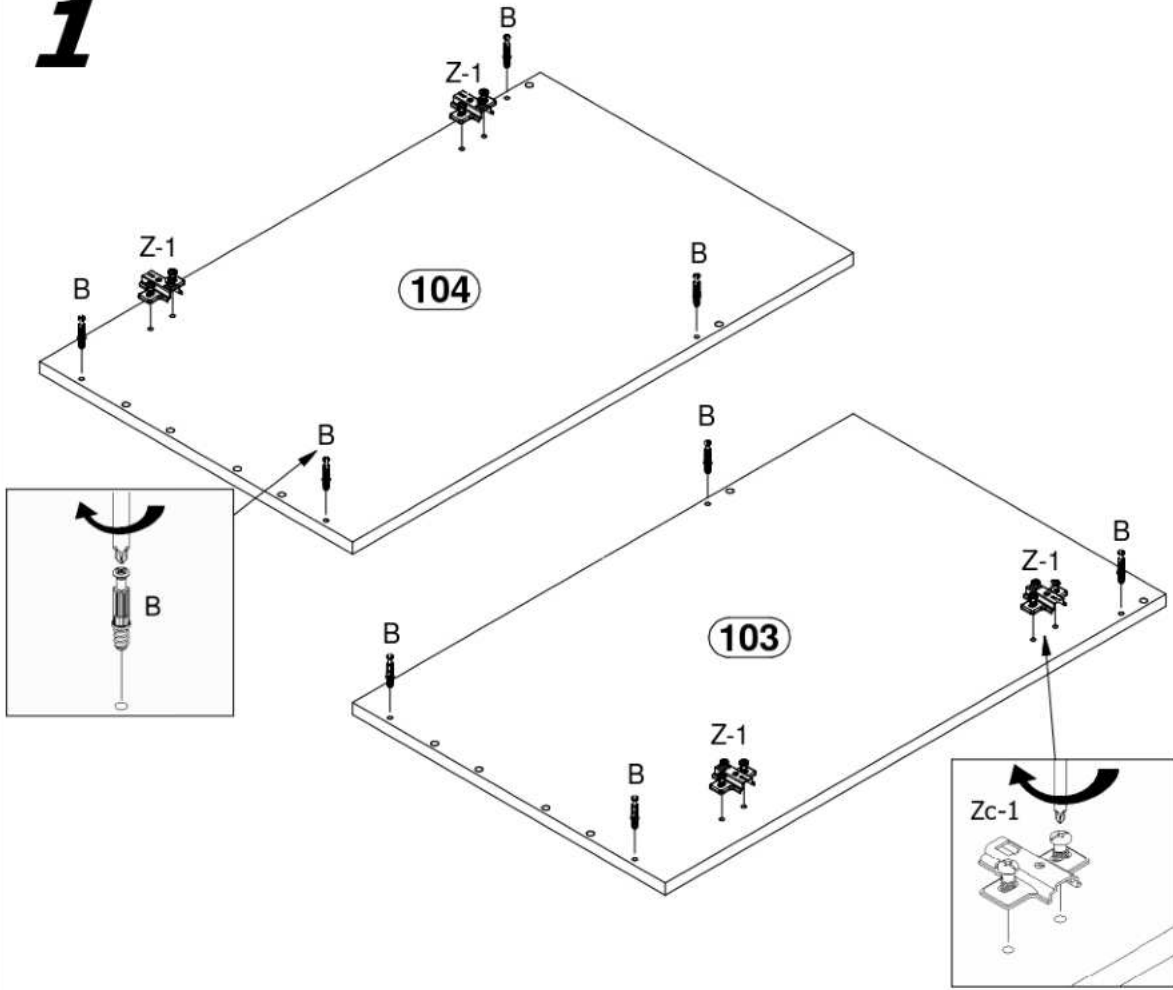

2

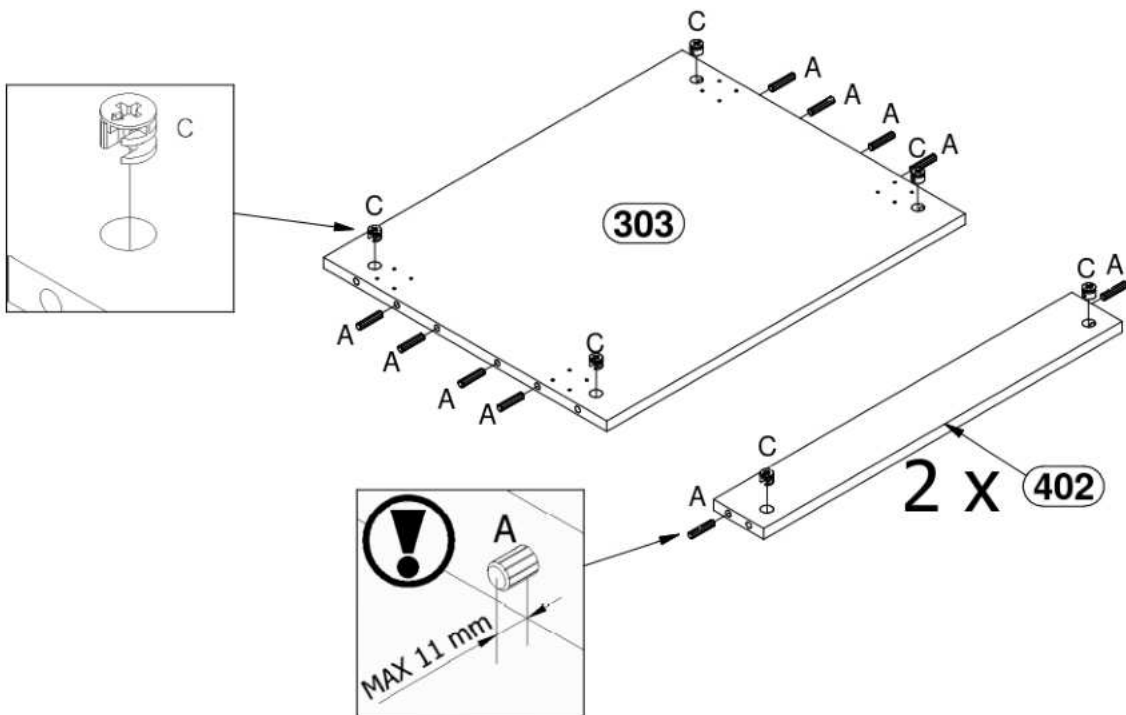

3

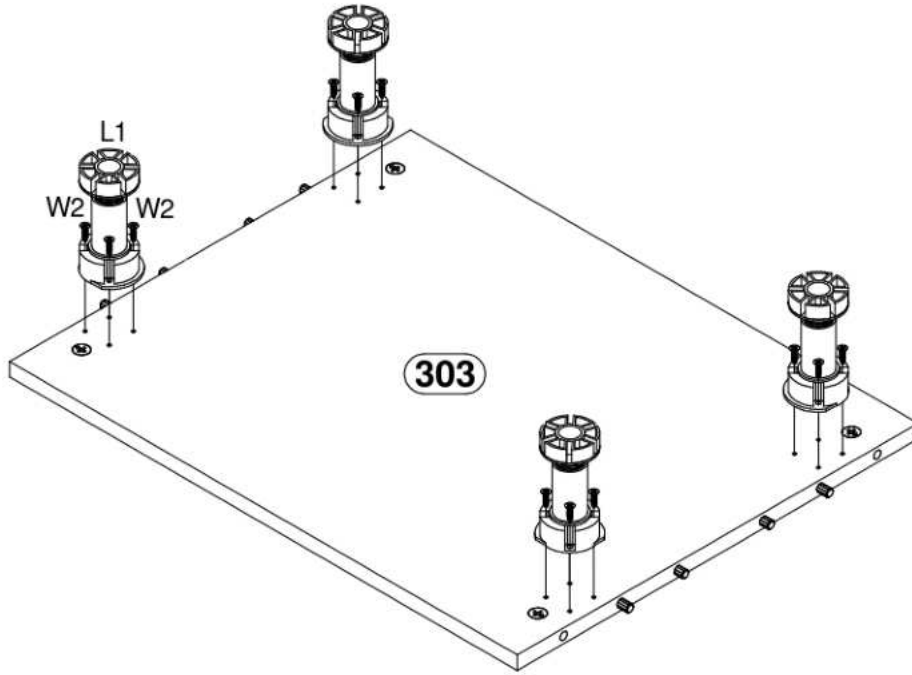

4

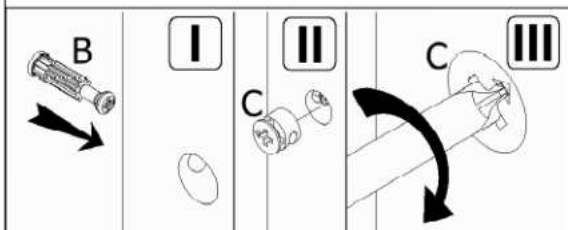
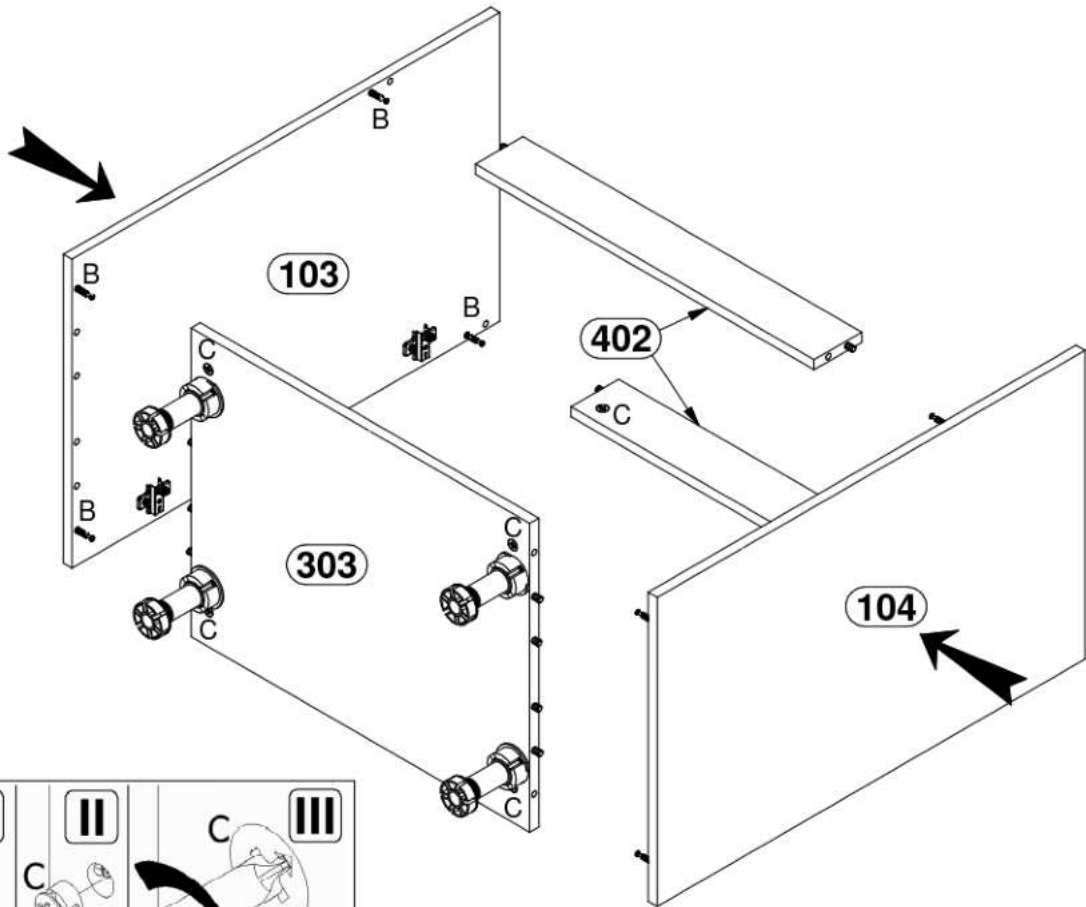

5

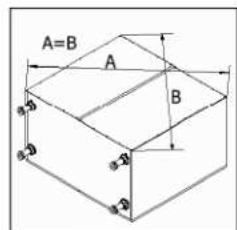
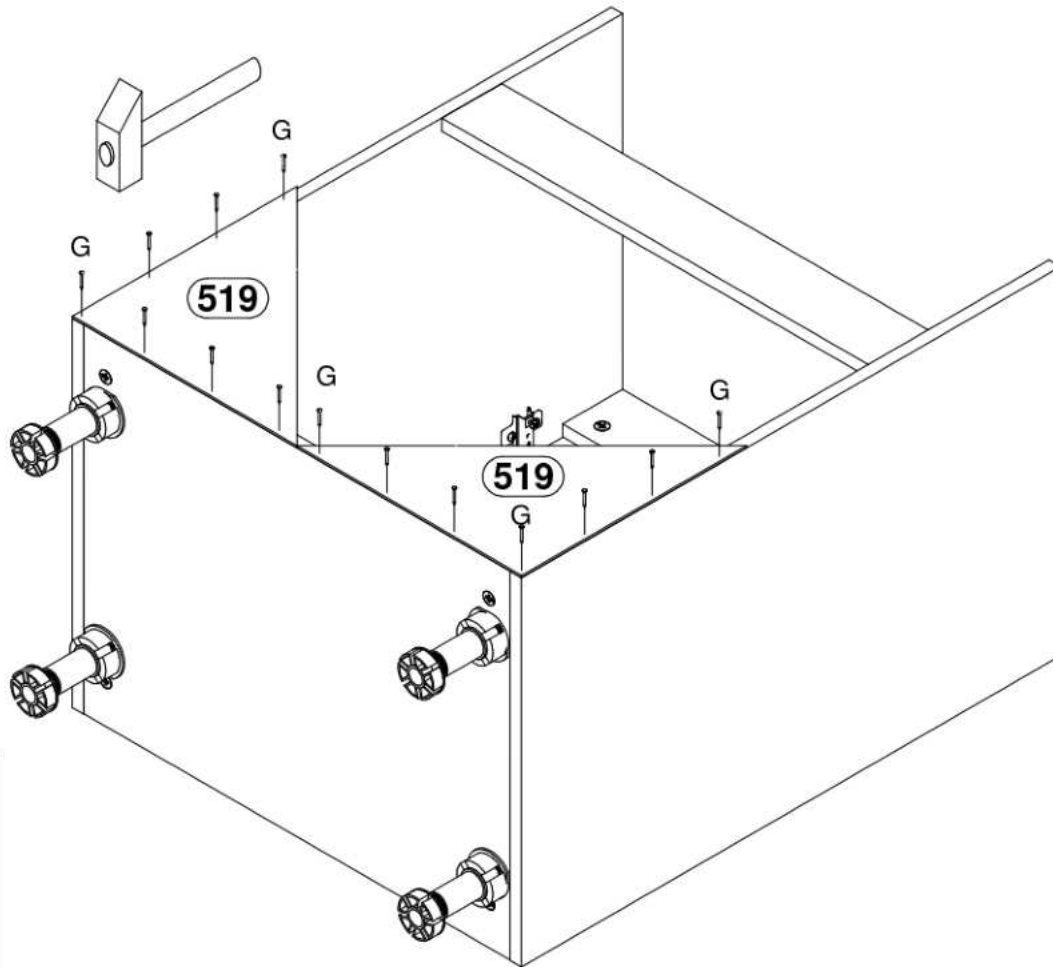

6

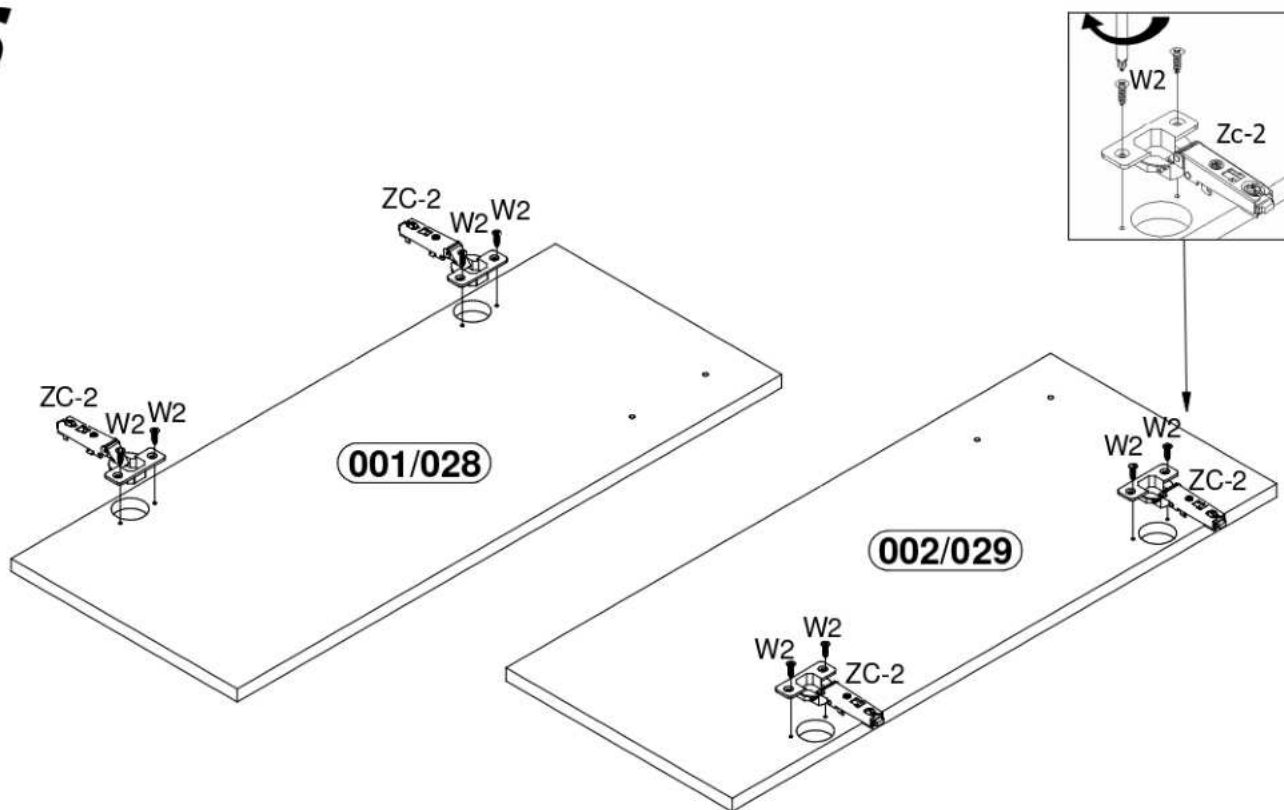

7

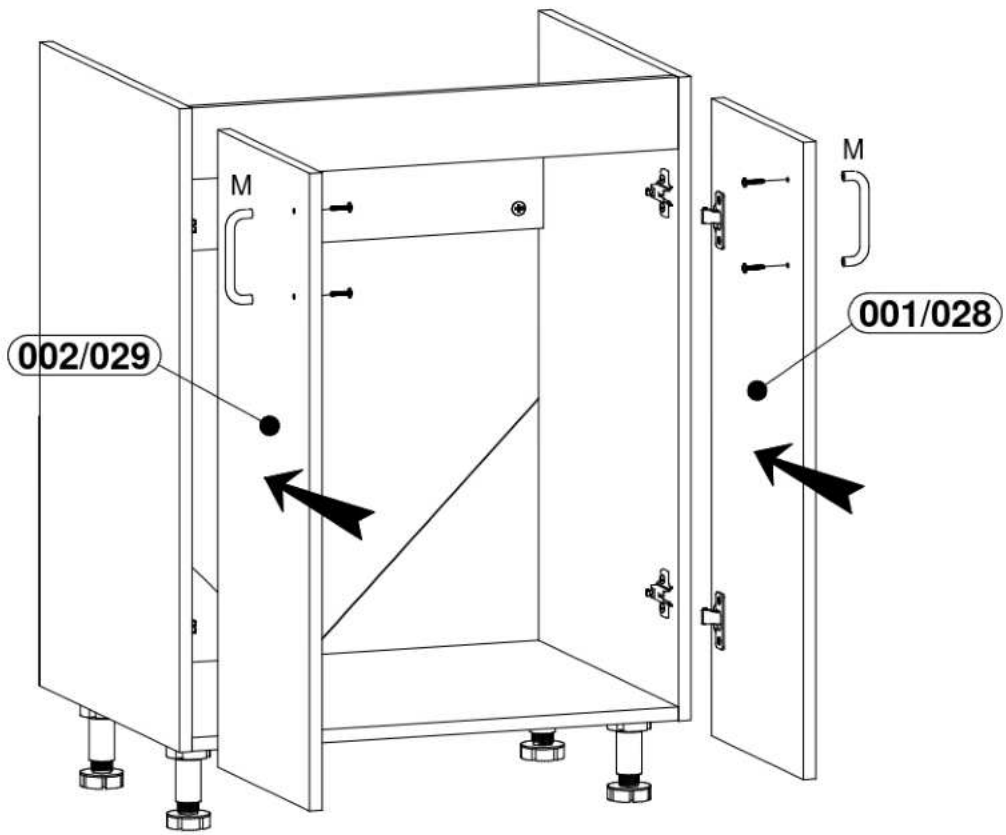

8

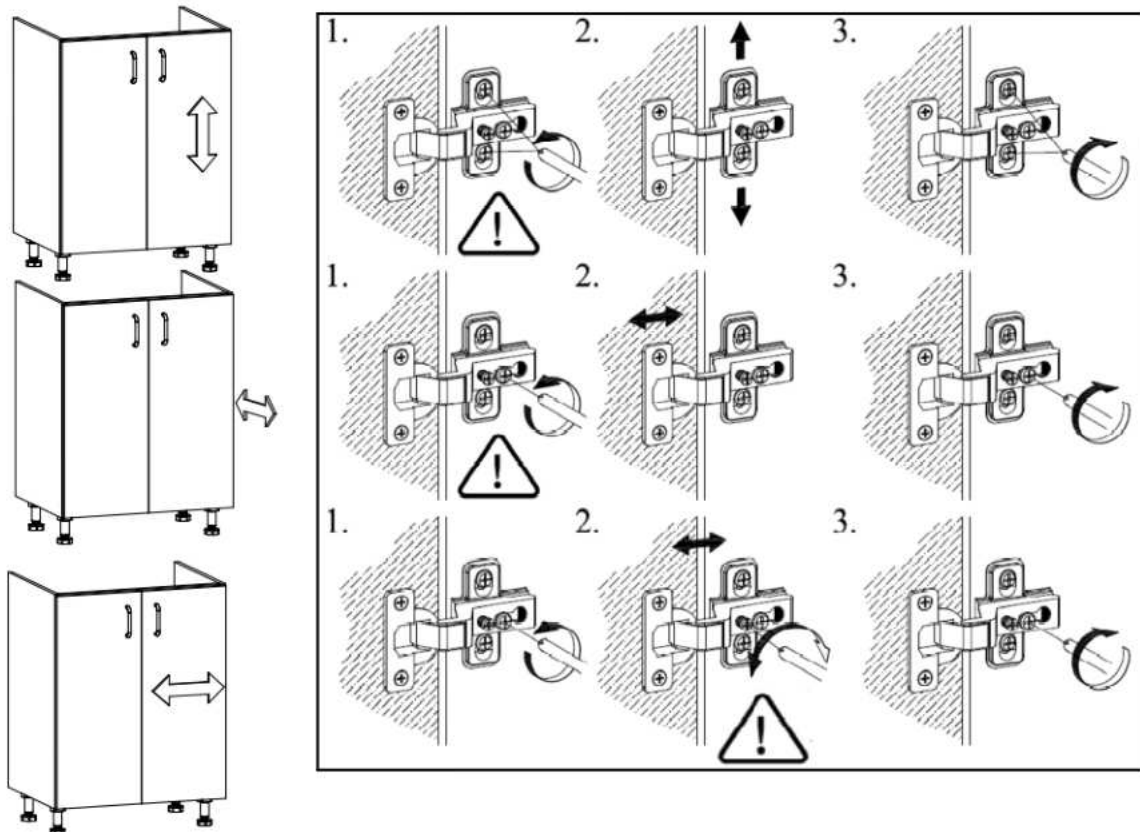

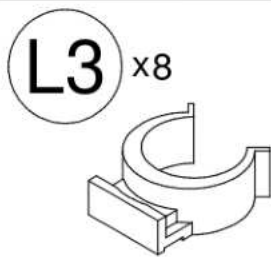
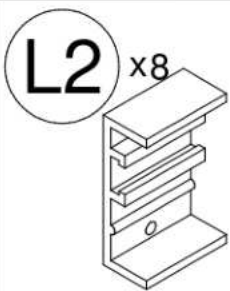
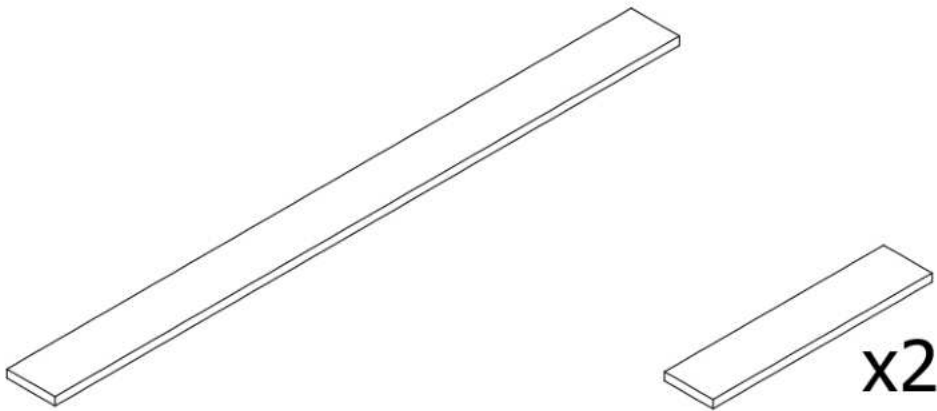
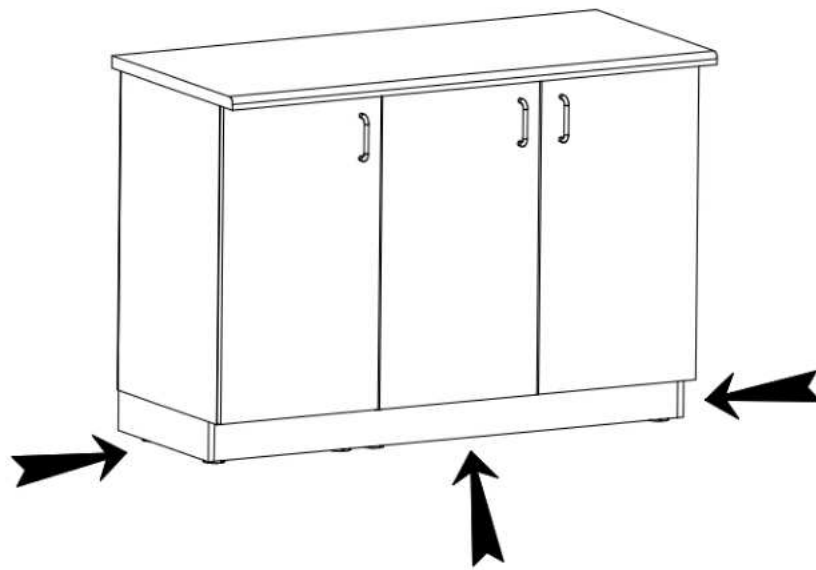

Ø3,5x16

9

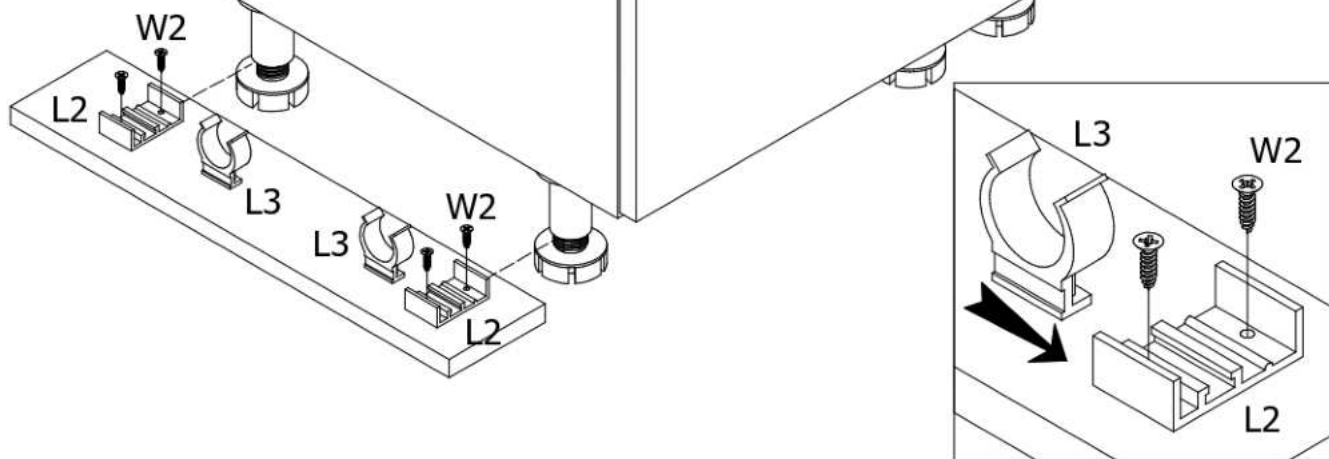

10

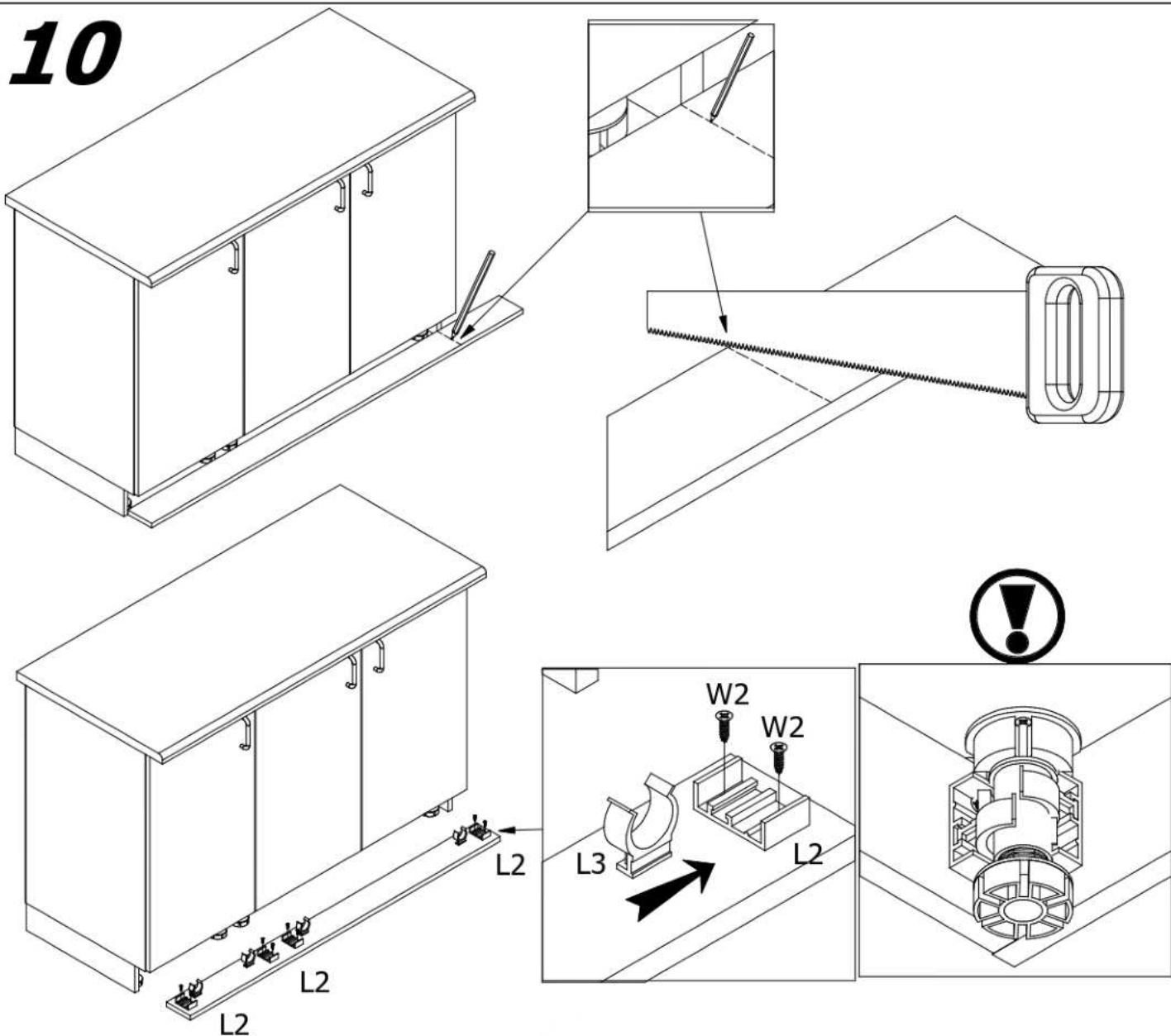





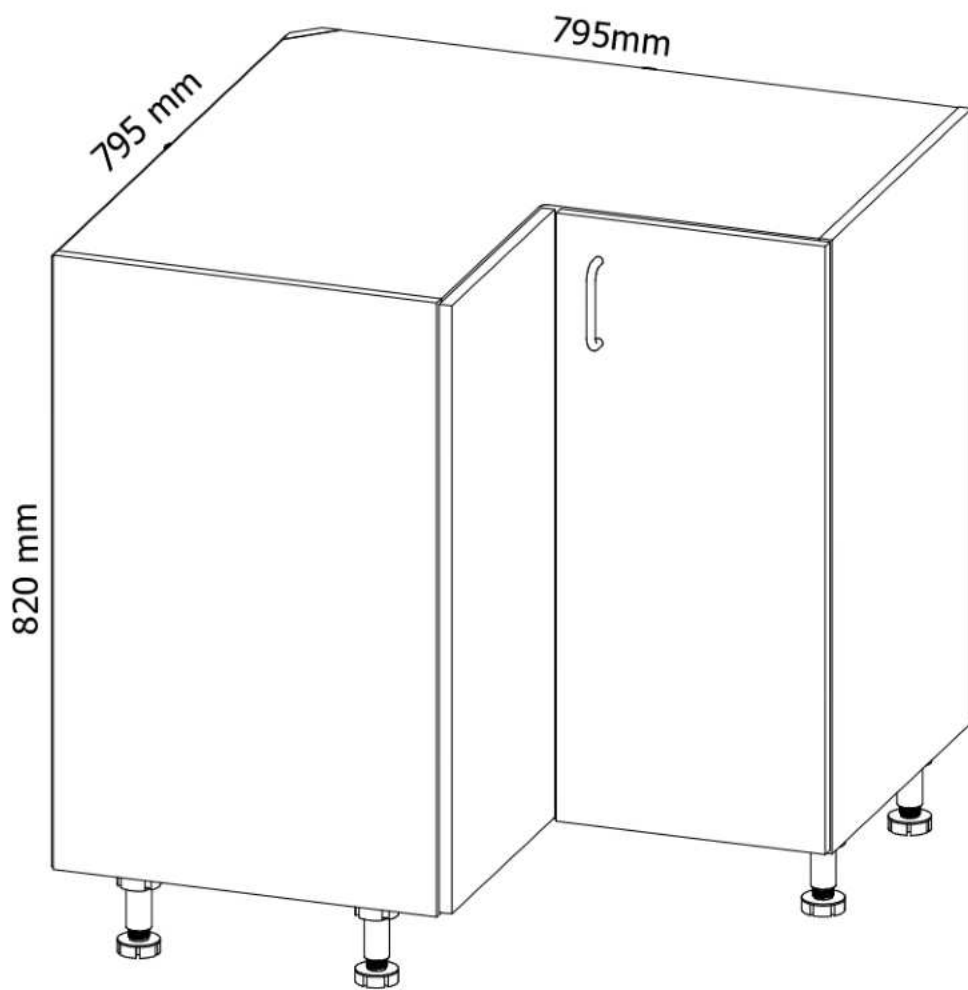

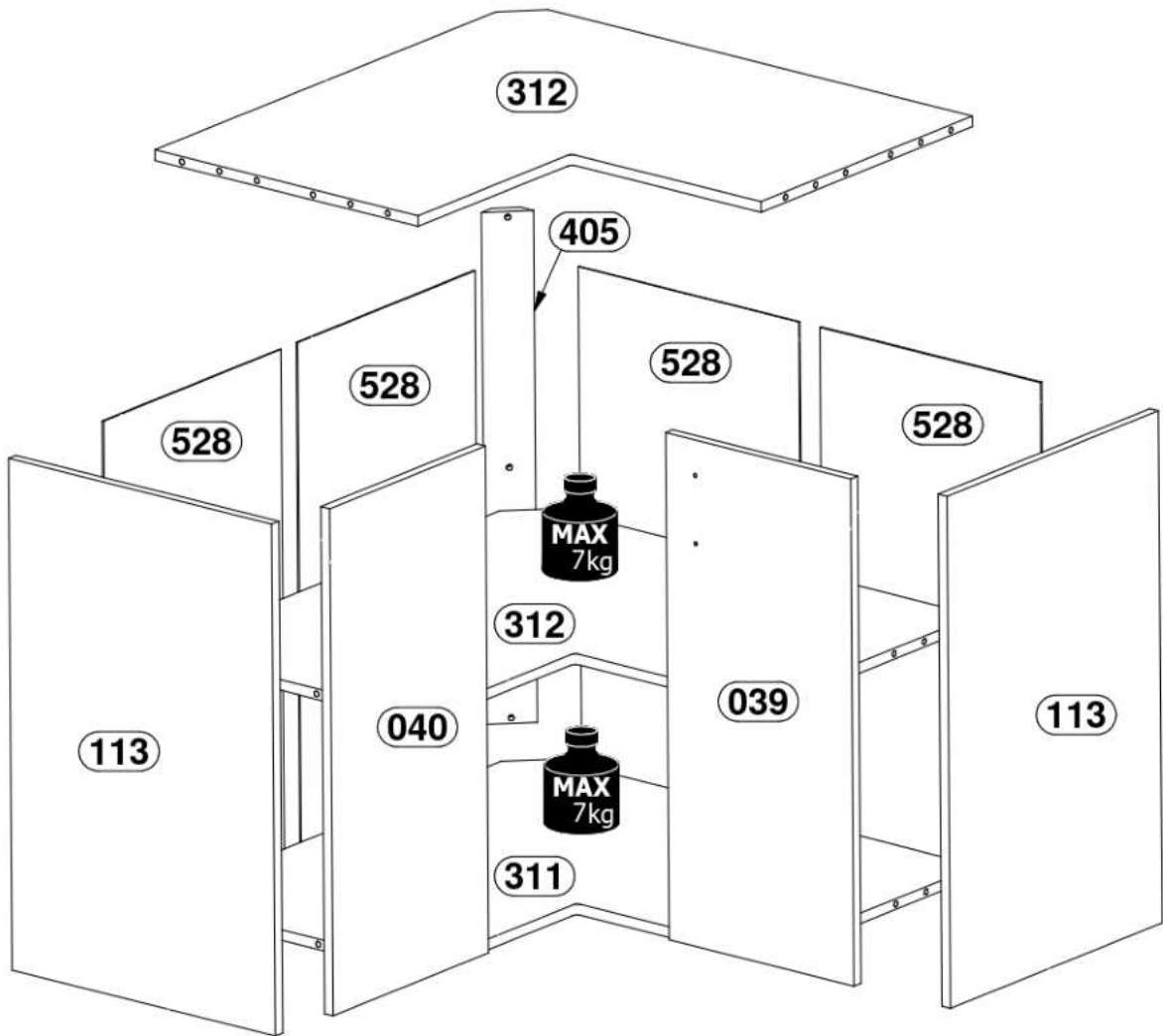
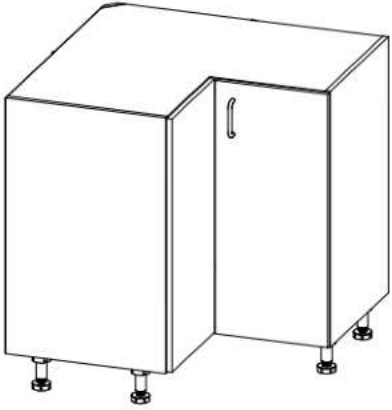

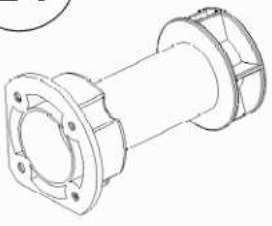
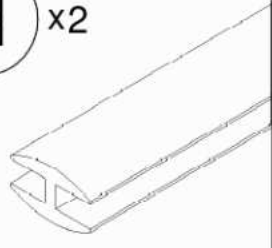

AURORA

D90N



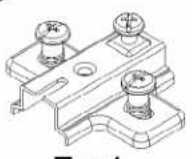

<p>A x24</p>  <p>Ø8x35mm</p>	<p>B x12</p> 	<p>C x12</p>  <p>Ø15x12mm</p>	<p>D x3</p>  <p>Ø6,4x50 mm</p>
<p>G x45</p> 	<p>L1 x5</p> 	<p>H x2</p>  <p>715 mm</p>	<p>M x1</p> 
<p>W2 x28</p>  <p>Ø3,5x16mm</p>	<p>Y x12</p>  <p>Ø18 mm</p>	<p>Y1 x3</p> 	
<p>Zg x4</p>  <p>Zg-1</p>  <p>Zg-2</p>			

1

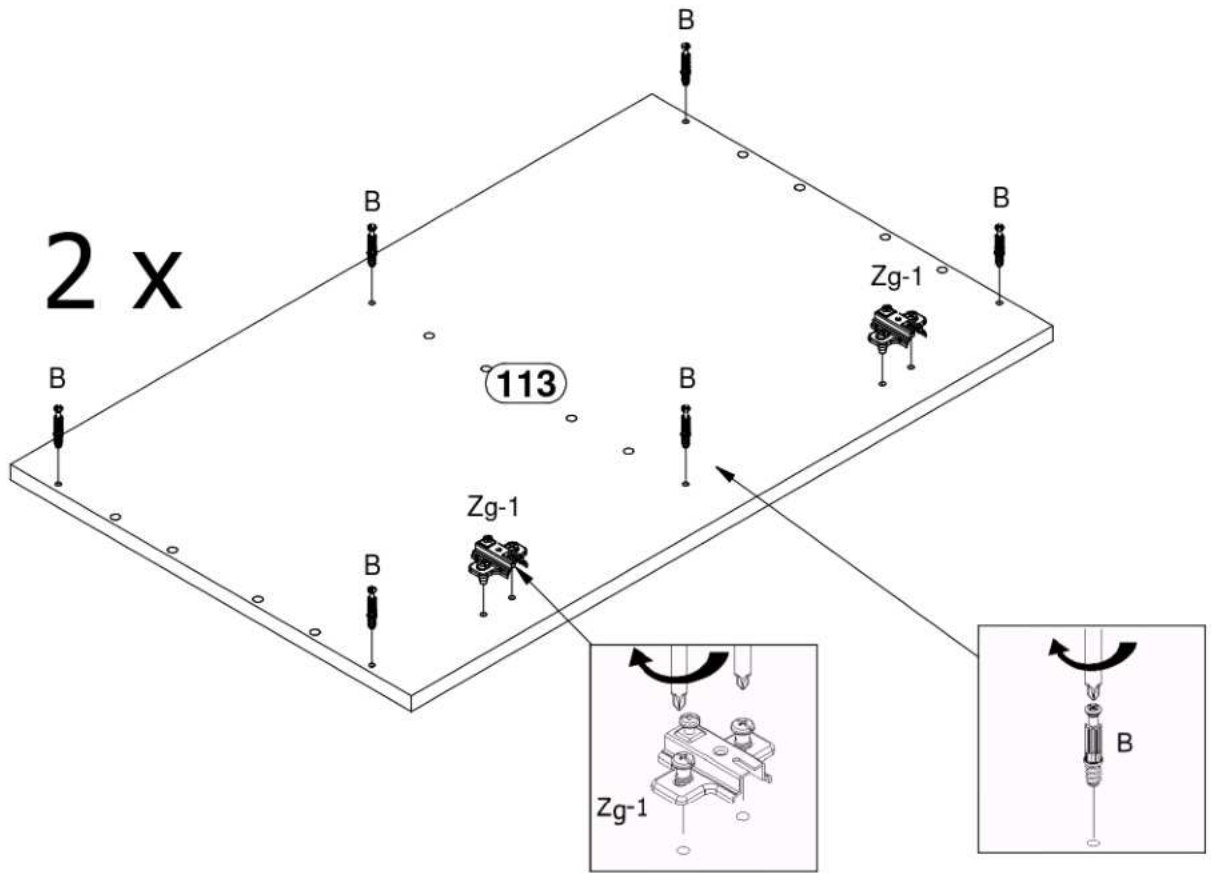

2

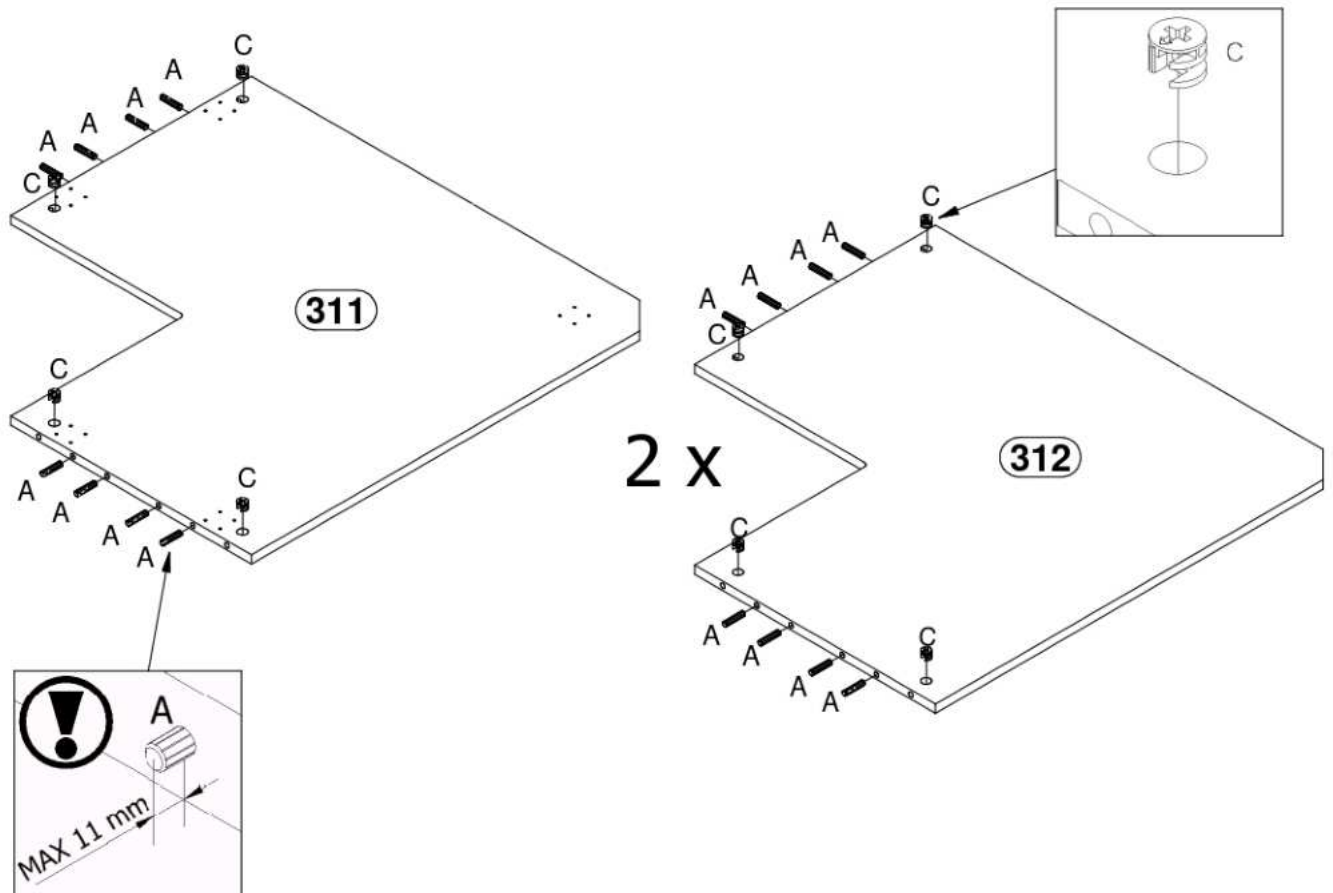

3

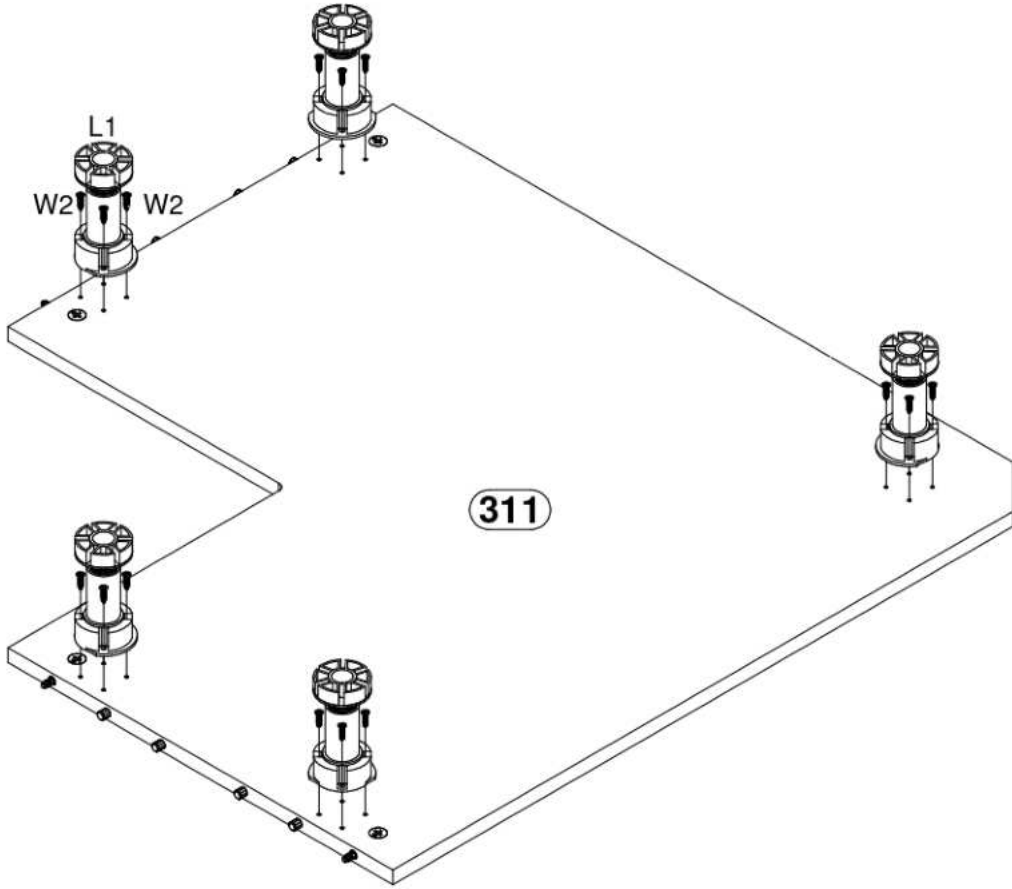

4

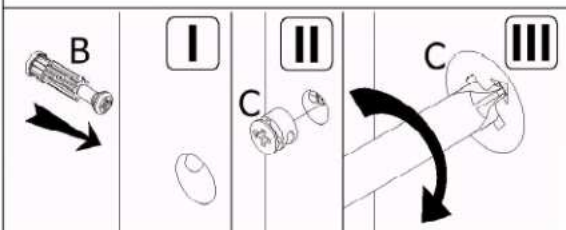
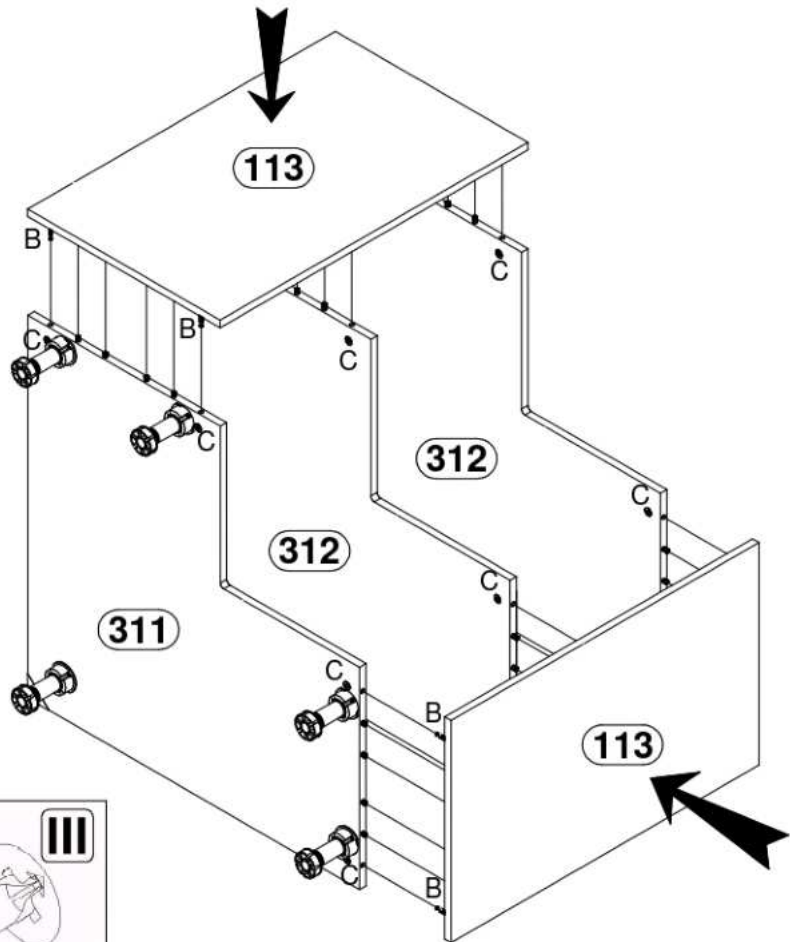

5

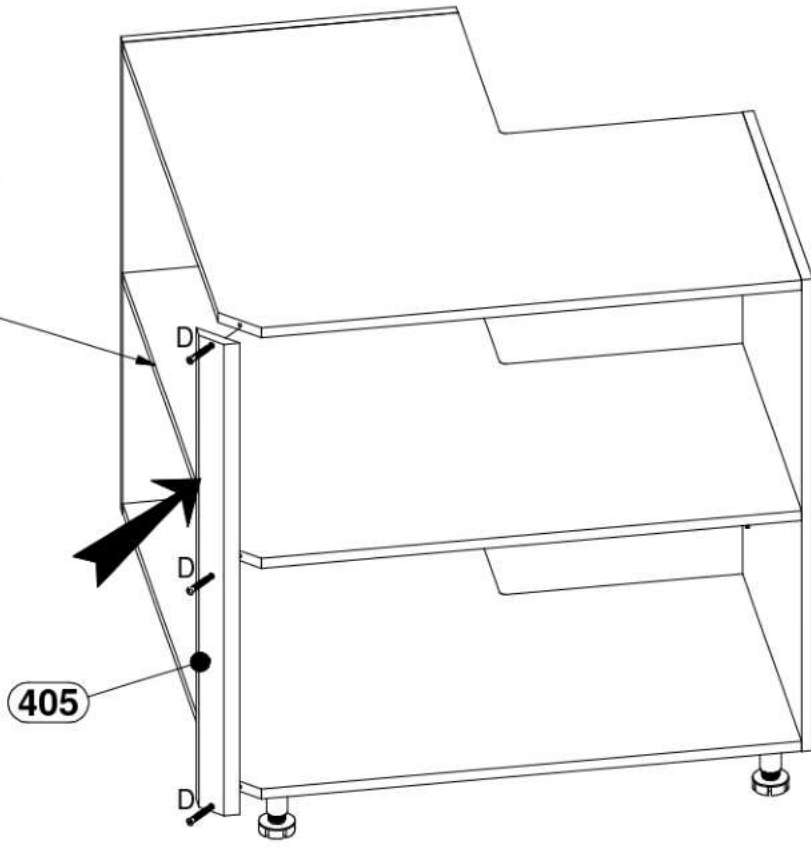
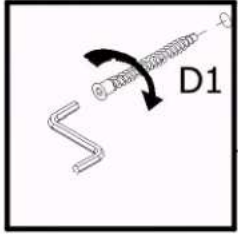

6

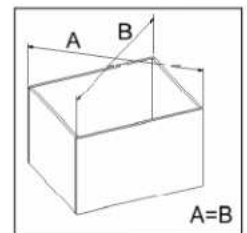
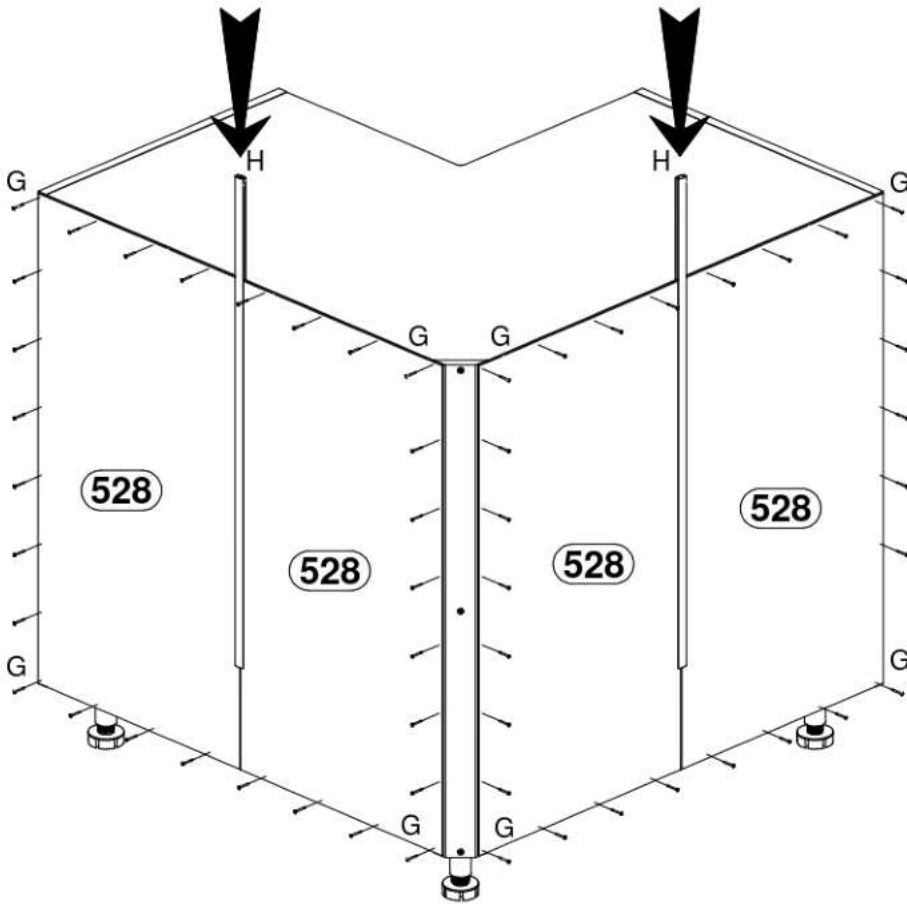

7

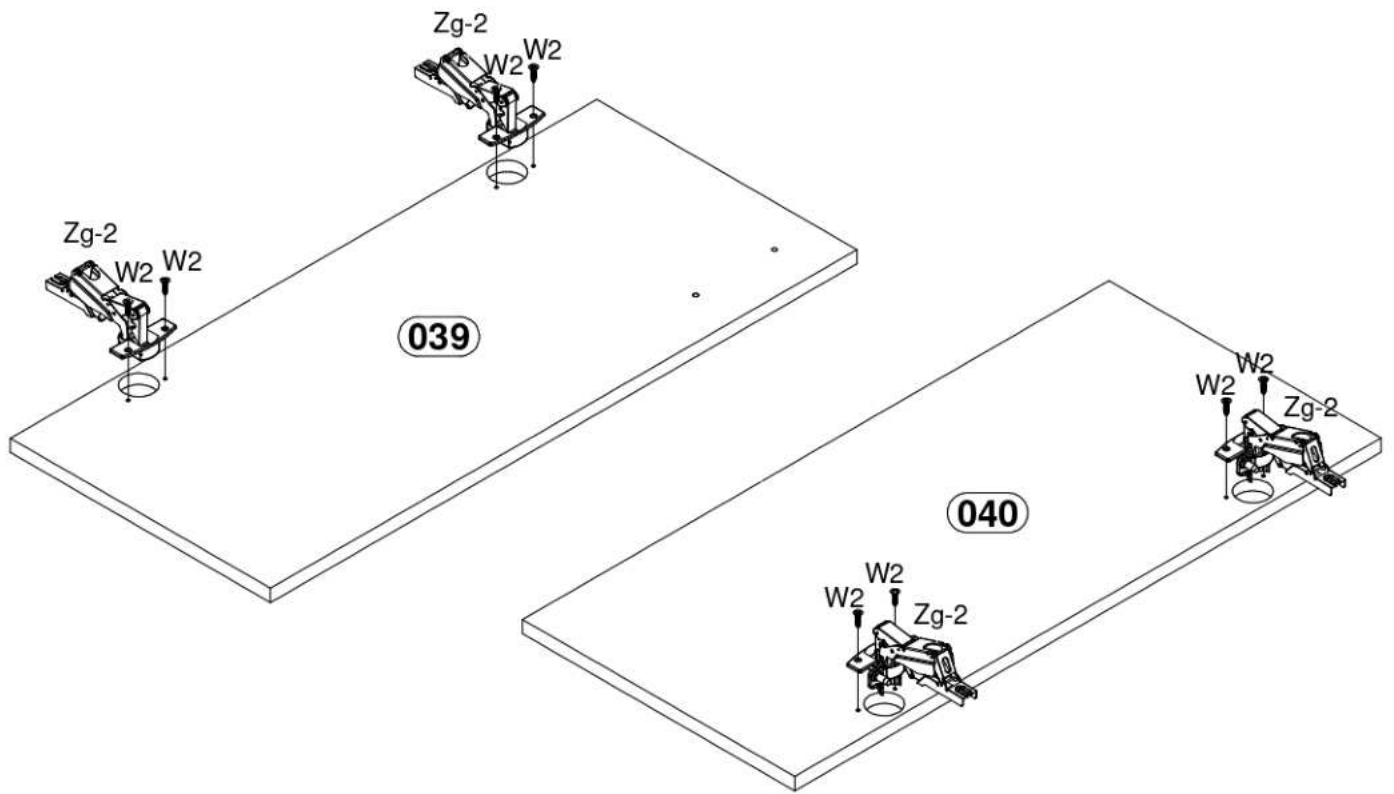

8

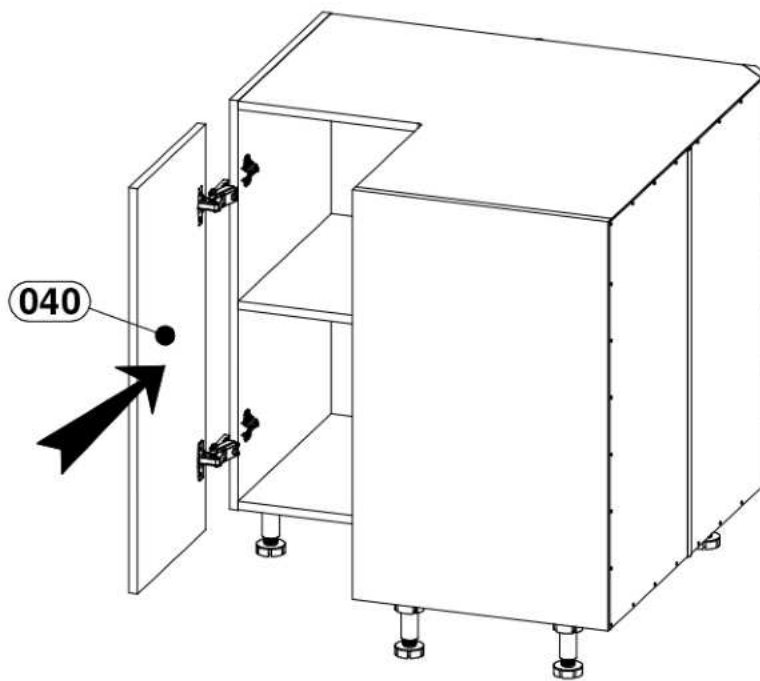

9

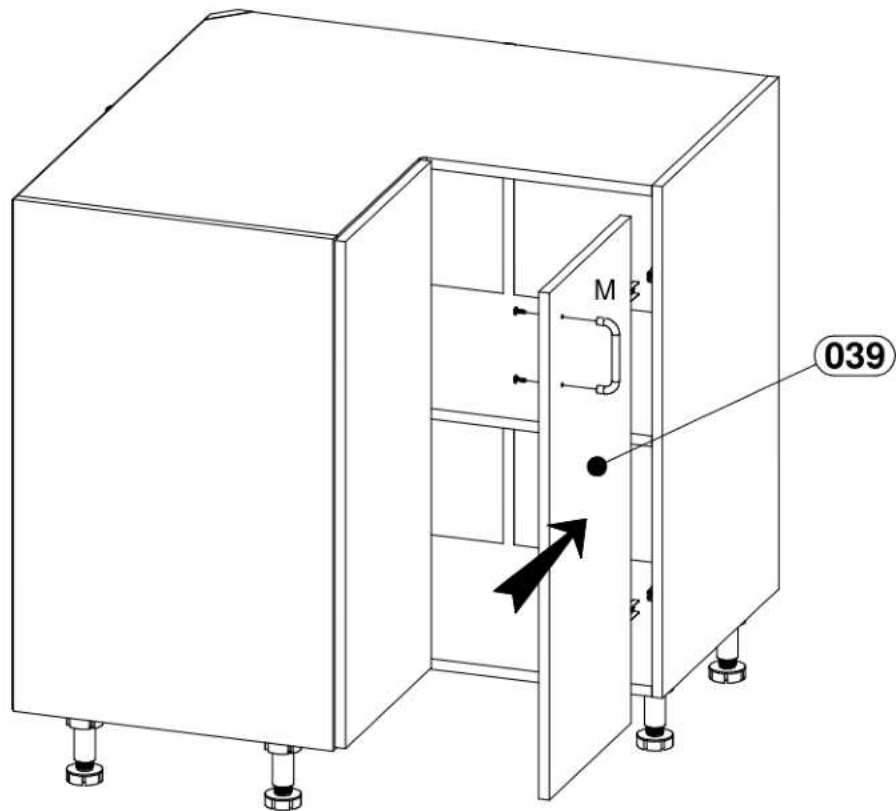

10

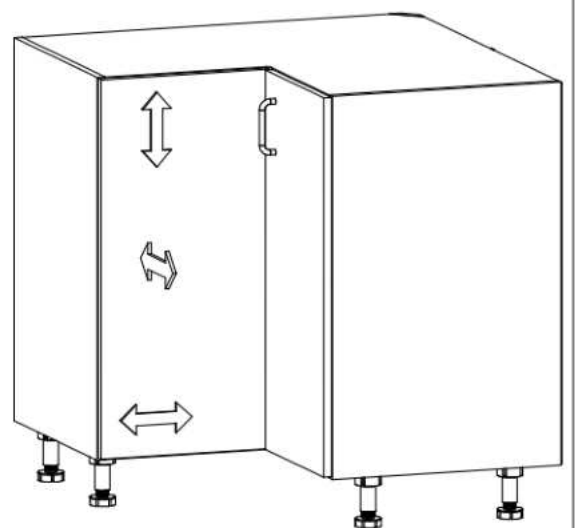
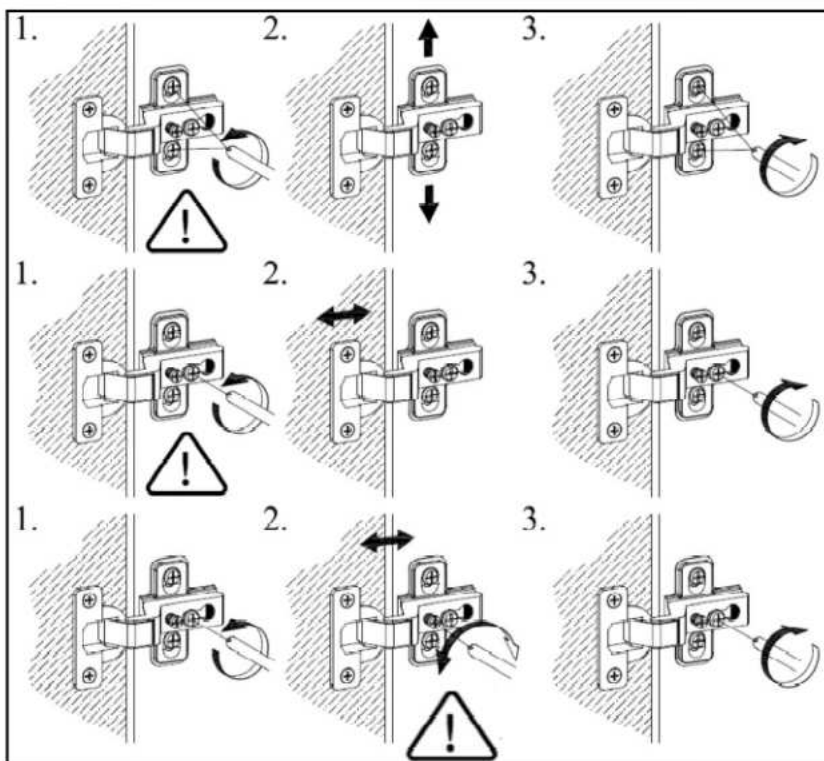

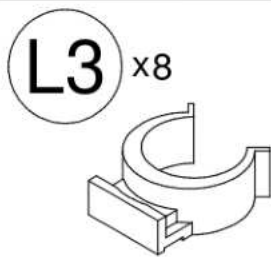
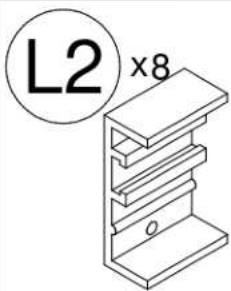
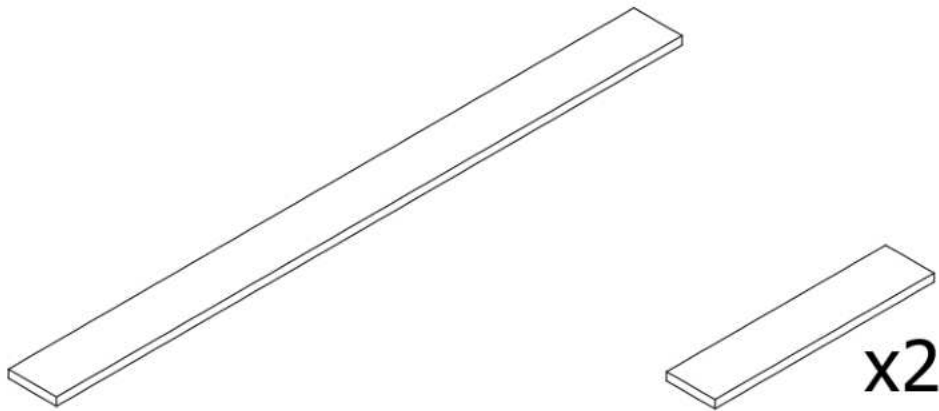
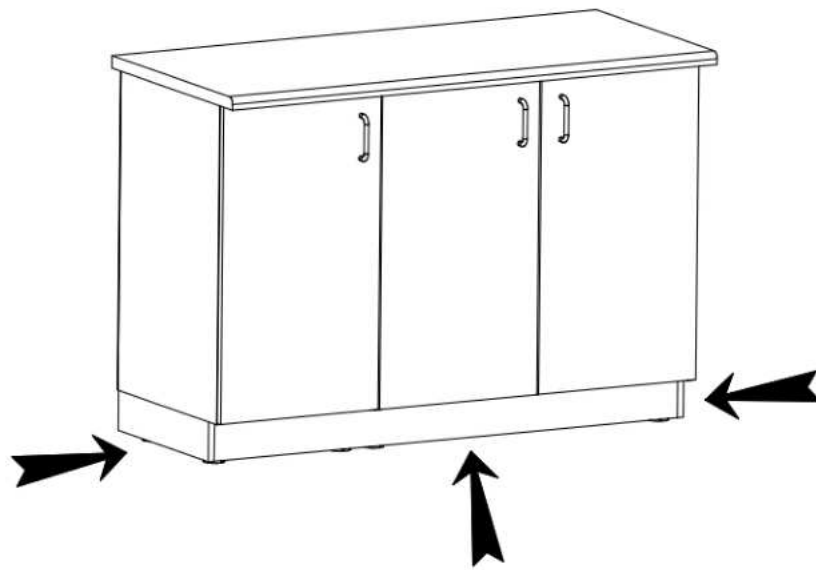

Ø3,5x16

11

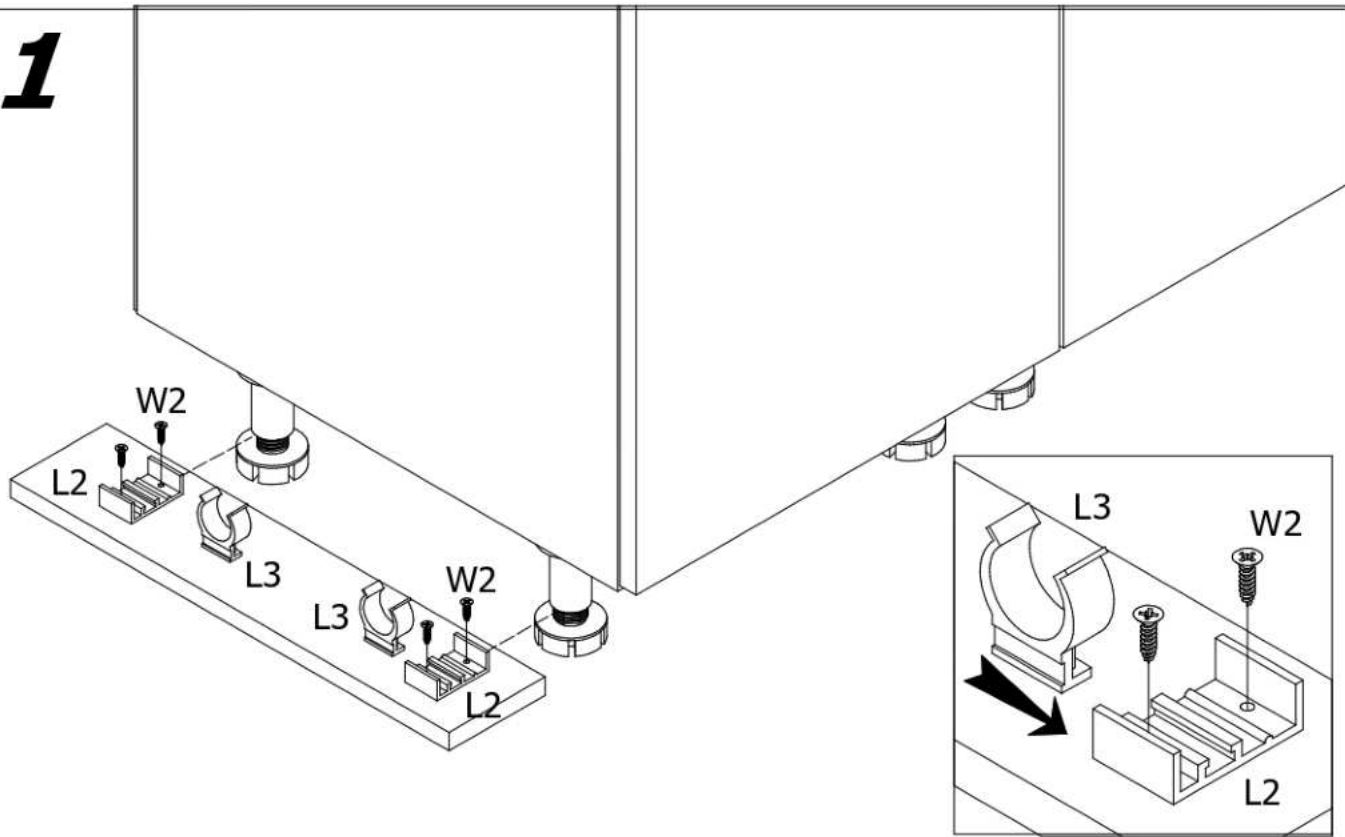

12

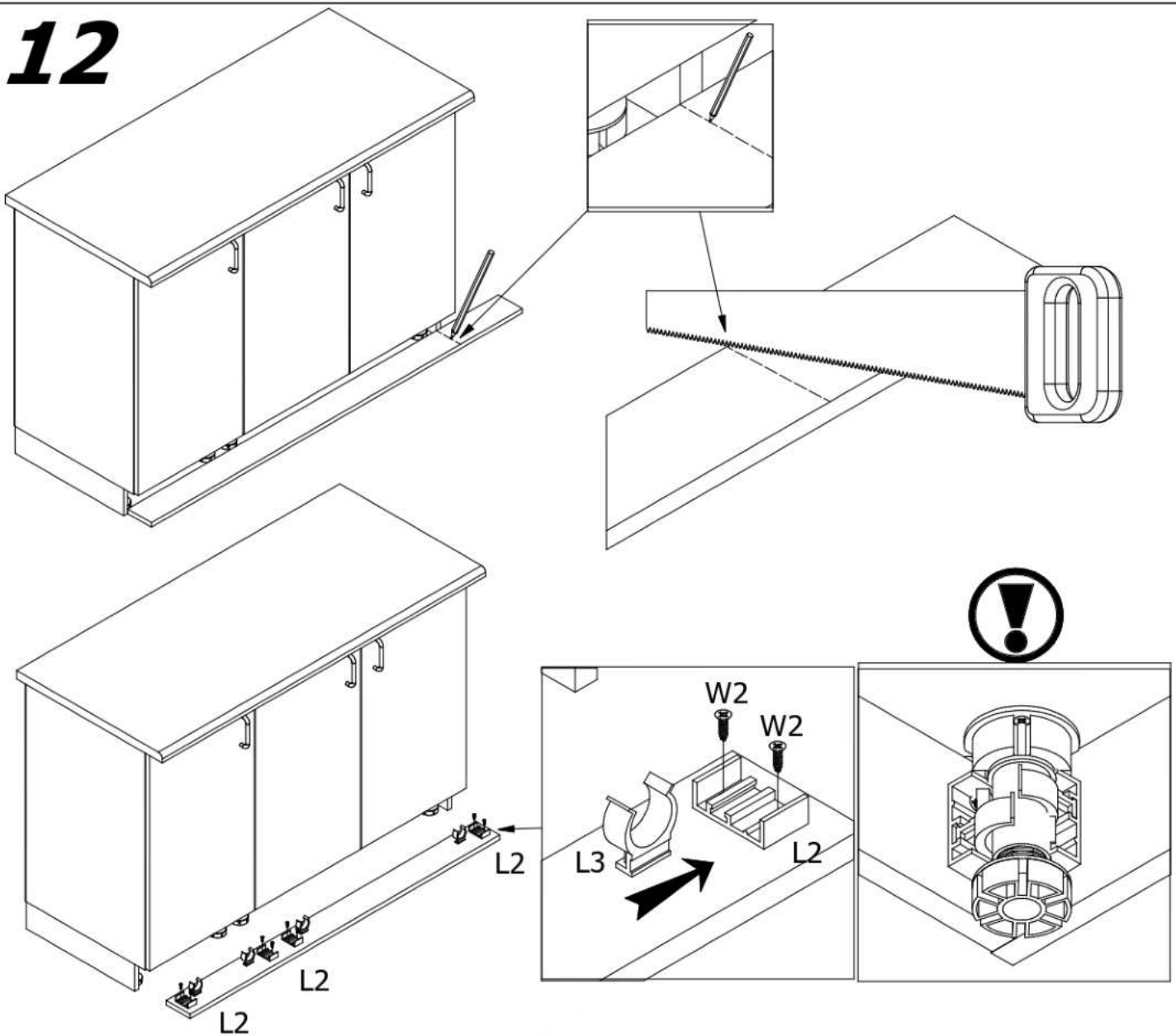





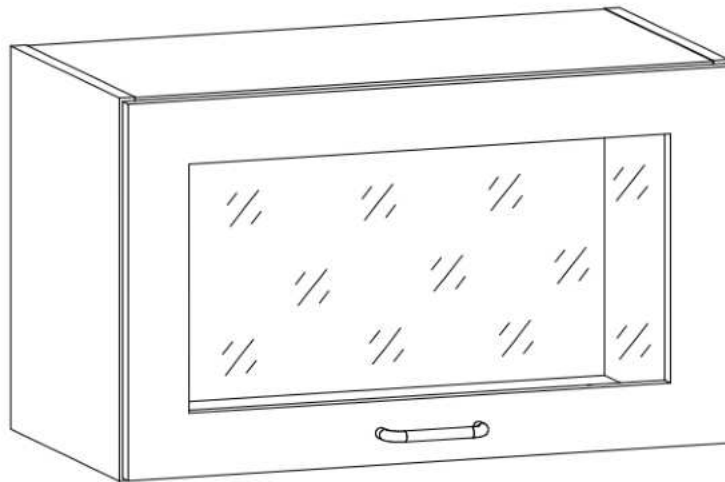
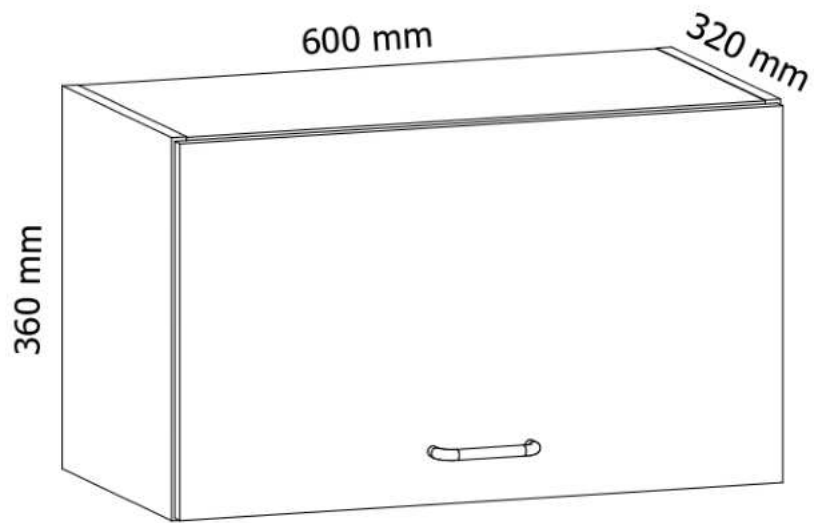

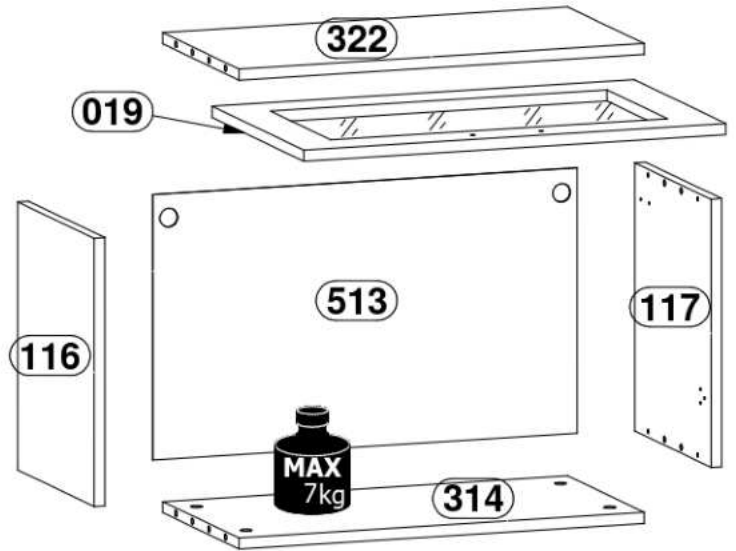
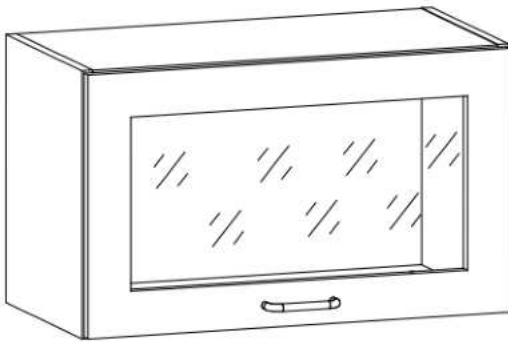
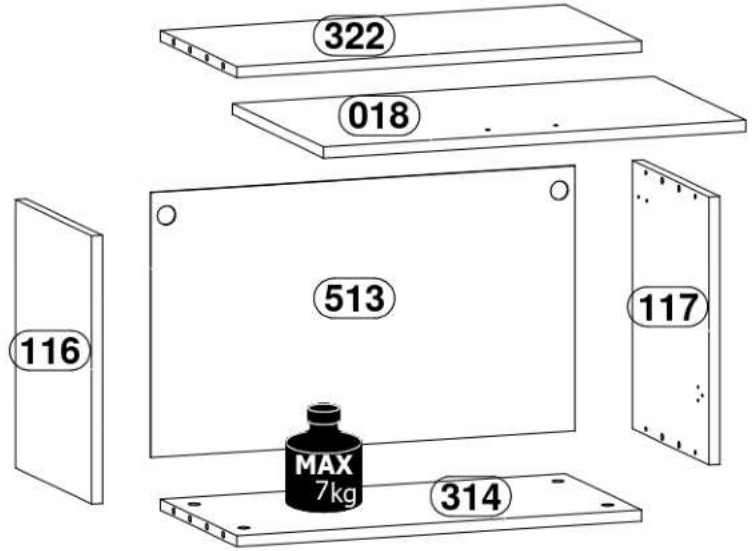
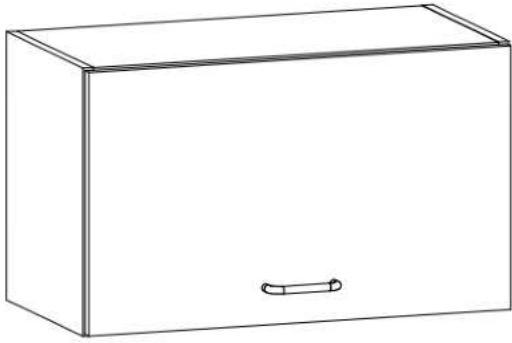



AURORA

G60KN

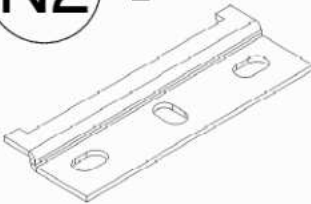
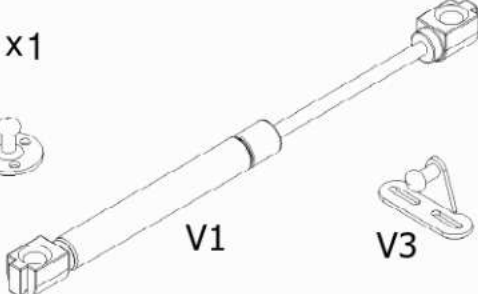

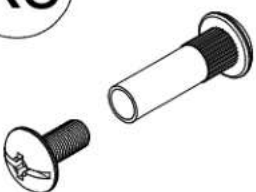

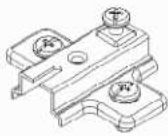
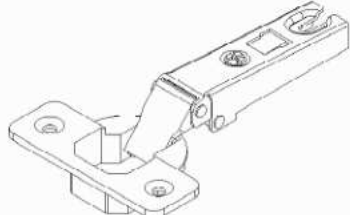
<p>A x8</p>  <p>Ø8x35mm</p>	<p>B x8</p> 	<p>C x8</p>  <p>Ø15x12mm</p>	<p>G x20</p> 
<p>M x1</p> 	<p>N1 x2</p> 	<p>N2 x2</p> 	
<p>V x1</p>  <p>V1</p> <p>V2</p> <p>V3</p>	<p>W2 x4</p>  <p>Ø3,5x16mm</p>	<p>W8 x4</p>  <p>Ø4x30mm</p>	
<p>X8 x2</p> 	<p>Y x8</p>  <p>Ø18 mm</p>	<p>Zn x2</p>  <p>Zn-1</p>  <p>Zn-2</p>	

1

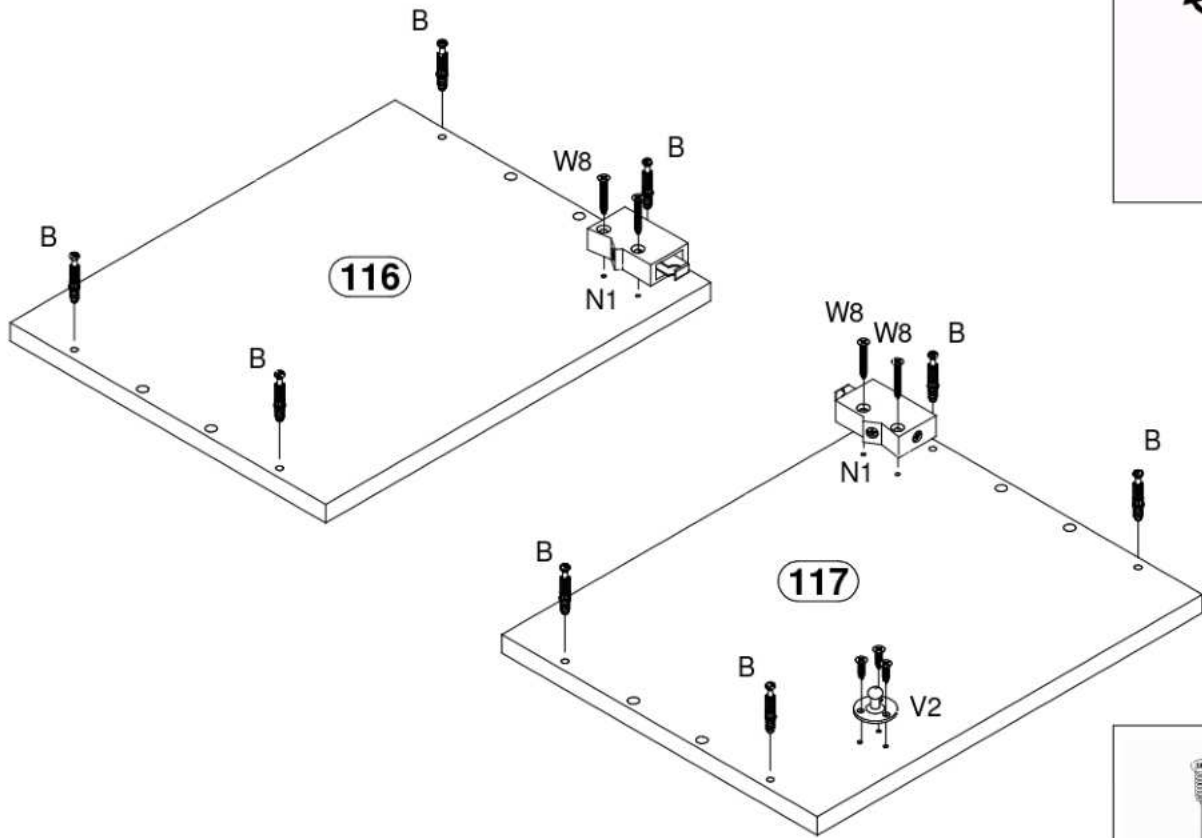

2

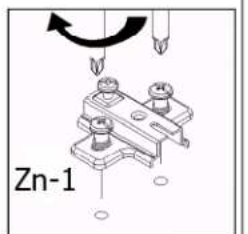
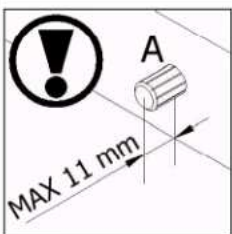
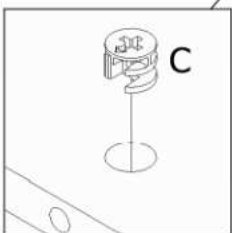
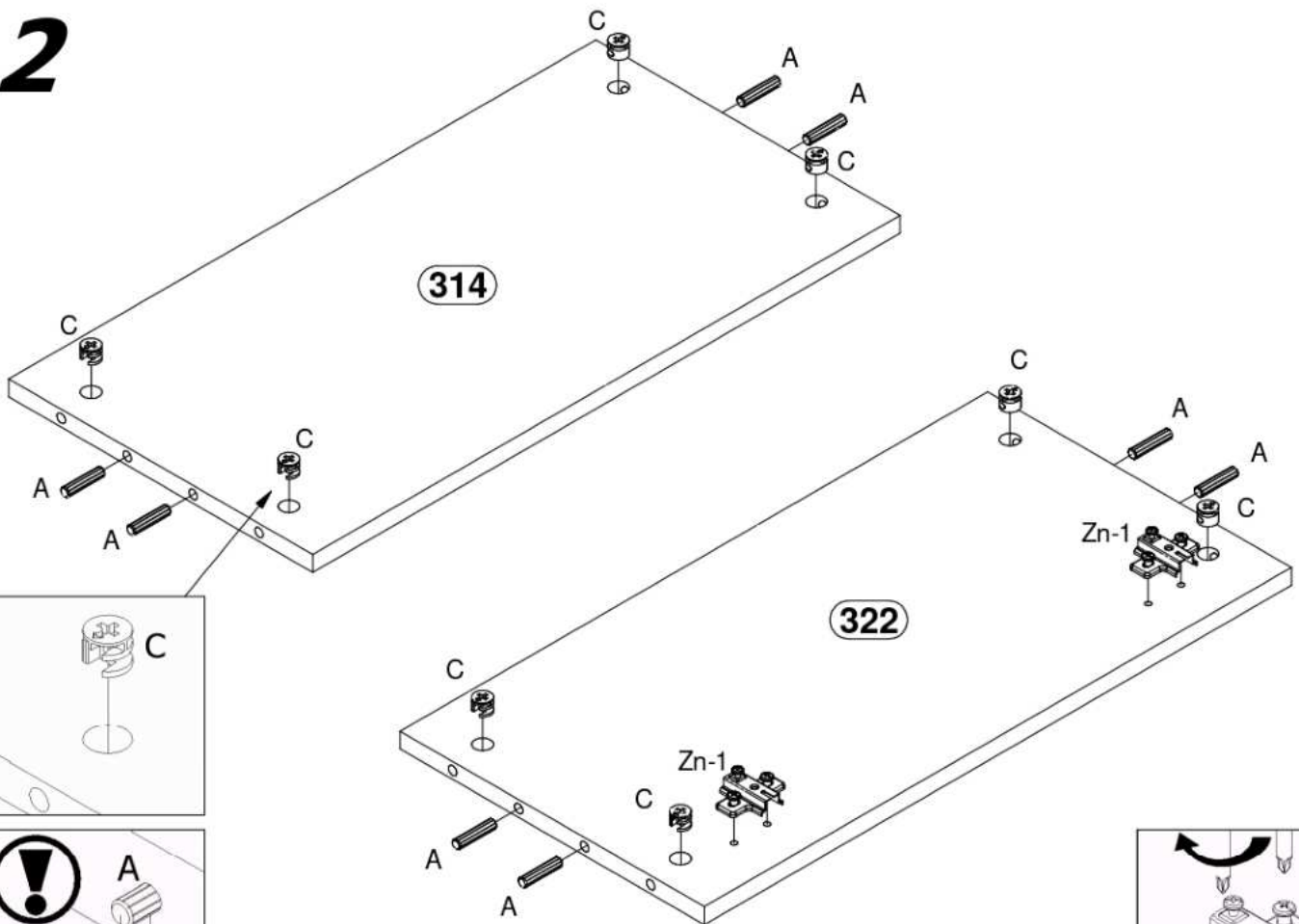

3

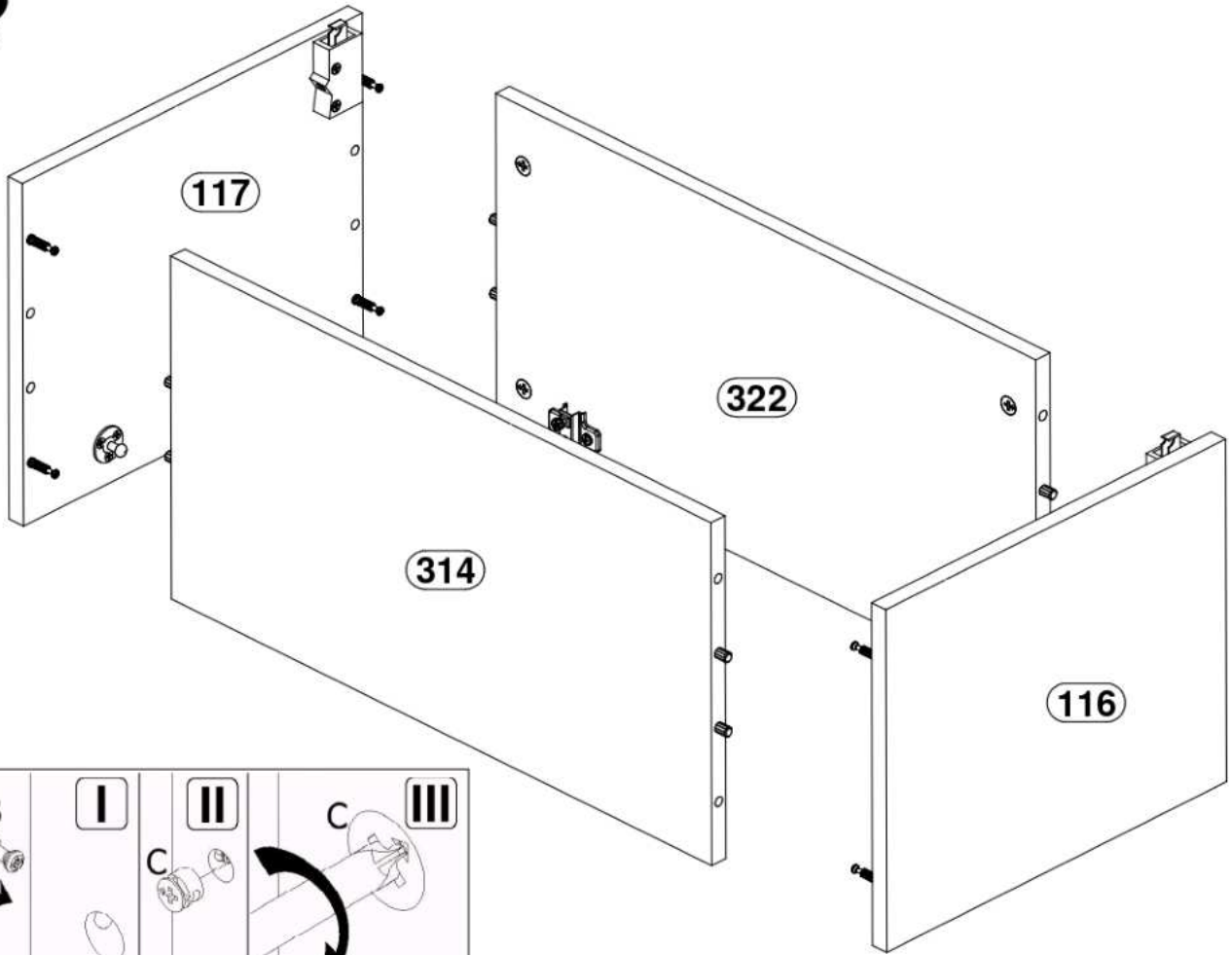

4

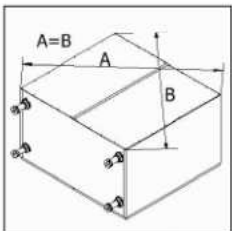
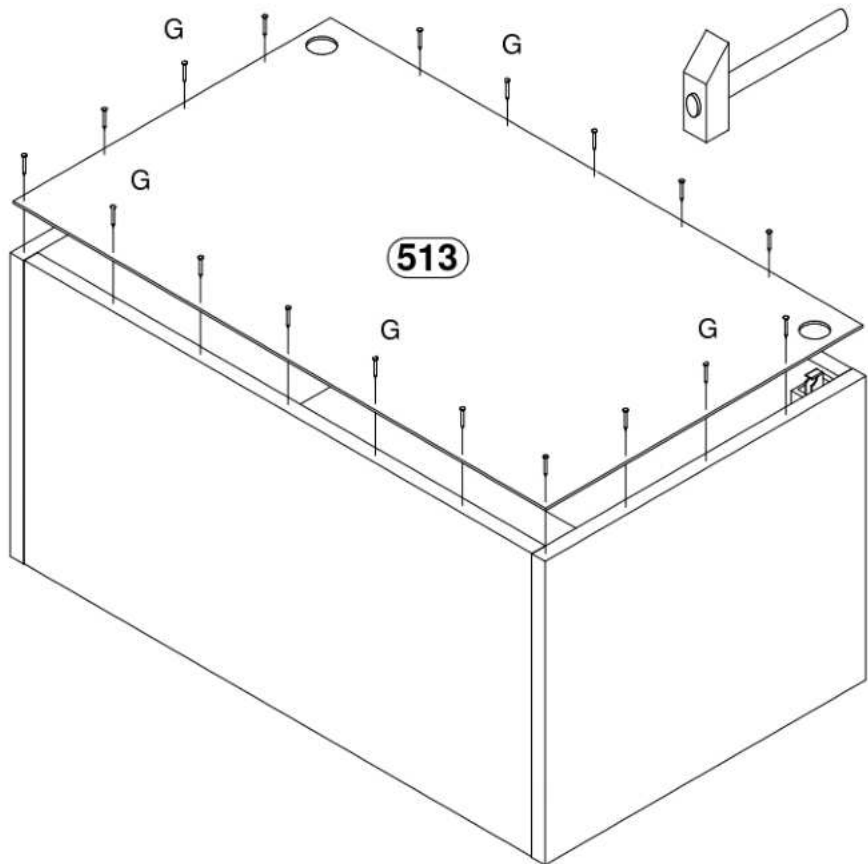

5

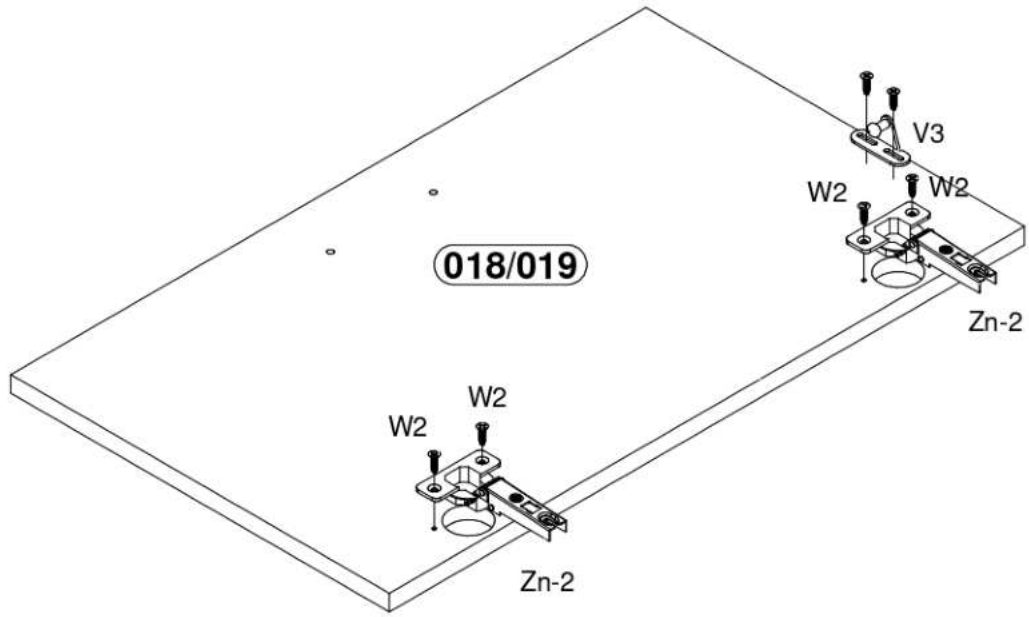

6

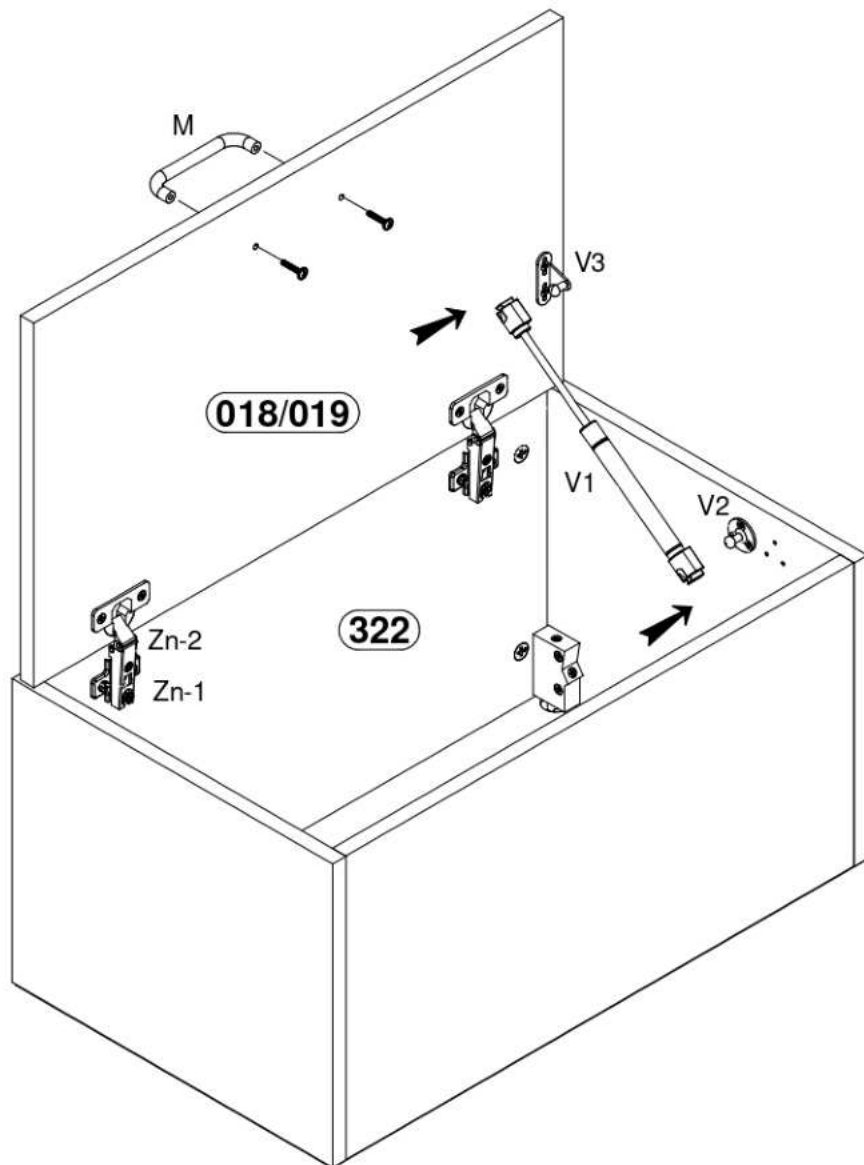

7

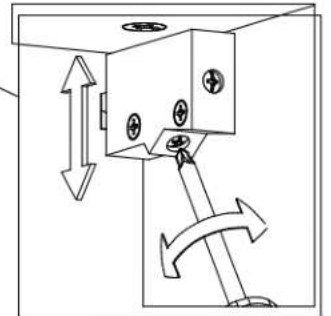
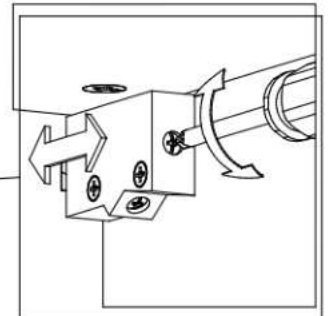
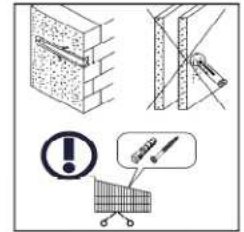
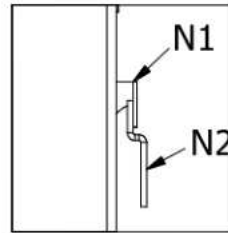
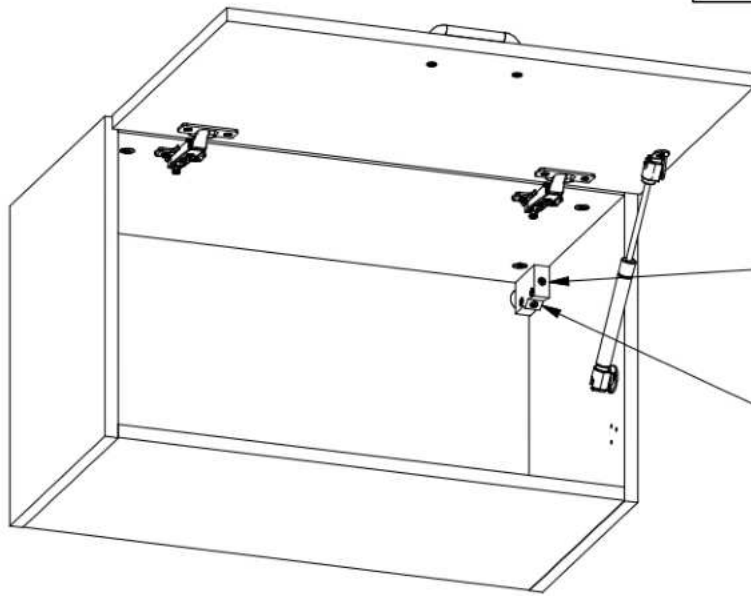

8

